

PREMIER UNDERCOUNTER

REFRIGERATORS AND FREEZERS OPERATION, MAINTENANCE AND INSTALLATION MANUAL



	<u>PAGES</u>
EN: OPERATION, MAINTENANCE AND INSTALLATION MANUAL	1-26
FR: MANUEL D'UTILISATION, D'ENTRETIEN ET D'INSTALLATION	27-52
DE: BEDIENUNG-, WARTUNGS- UND MONTAGEANLEITUNG	53-78
ES: MANUAL DE OPERACIÓN, MANTENIMIENTO E INSTALACIÓN	79-104
NL: EXPLOITATIE- ONDERHOUD- EN INSTALLATIEHANDLEIDING	105-130
DA: BETJENINGS-, VEDLIGEHOLDELSES- OG INSTALLATIONS	131-156
IT: MANUALE D'USO, DI MANUTENZIONE E DI INSTALLAZIONE	157-182
SV: HANDBOK FÖR ANVÄNDNING, UNDERHÅLL OCH INSTALLATION	183-208
NO: DRIFTS-, VEDLIKEHOLDS- OG INSTALLASJONSHÅNDBOK	209-233

I. GENERAL INFORMATION	2
II. OPERATING INSTRUCTIONS	7
III. CONTROL PANEL	9
IV. MAINTENANCE INSTRUCTIONS	10
V. TECHNICAL INFORMATION	12
VI. COOLING DIAGRAM – ELECTRICAL WIRING DIAGRAM	21
VII. SERVICE DIAGNOSIS	23
VIII. REMOVAL AND REPLACEMENT	24

Contact Details:
HOSHIZAKI EUROPE B.V.
 Address: Burgemeester Stramanweg 101 1101 AA Amsterdam, The Netherlands
 Tel: +31 (0)20 691 84 99 - <http://hoshizaki-europe.com/>

HOSHIZAKI

PREMIER UNDERCOUNTER



I. GENERAL INFORMATION

PRODUCT DESCRIPTION LABEL

1- Product Number
2 - Product Description
3 - Model
4 - Refrigerant (GWP)
5 - CO2 Equivalent
6 - IP Protection
7 - Climate Class
8 - Production Date
9 - Total power / Current / Lamp power
10 - Voltage - Frequency
11 - Heating Element
12 - System Pressure
13 - Blowing Agent
14 - Serial Number

PRODUCT NUMBER	1
	
PRODUCT DESCRIPTION	2
MODEL	3
REFRIGERANT	4
CO2 EQUIVALENT	5
IP PROTECTION	6
CLIMATE CLASS	7
PRODUCTION DATE	8
TOTAL POWER / CURRENT / LAMP POWER	9
VOLTAGE - FREQUENCY	10
HEATING ELEMENT	11
SYSTEM PRESSURE	12
BLOWING AGENT	13

S/N: 14



HOSHIZAKI EUROPE B.V. Burgemeester Stramanweg 101 1101 AA
Amsterdam, The Netherlands



THE PURPOSE OF USAGE

- This product is suitable for use in indoor areas only and solely for the purpose of storing food and beverages. Storage units designed to maintain product already at refrigerator/freezer temperature.
- The manufacturer will not be held responsible for any damages arising because of usage contrary to stated guideline in this book.
- While storing food in this cabinet, it is necessary to ensure that food never meets the body of this cabinet.
- All foods must be completely covered. To avoid contamination and corrosion of internal components all products should be wrapped or stored in sealed containers.
- Do not store hot foods or liquids in this cabinet.
- Beverages stored in boxes and glass bottles should not be stored at temperatures below 0°C (freezing point). Cans and glass bottles may burst due to expansion. All containers with lids should not be filled completely: a small amount of space should be left for expansion.
- This cabinet is equipped with an automatic self-defrosting facility. It is also possible to perform manual defrosting. The manual defrosting does not involve turning the cabinet off for long periods but can be performed via the controller. Under nocircumstances should force or hand tools to be used to de-ice this cabinet, any damage arising from such action is difficult to repair.
- Do not employ any mechanical or alternative means of defrosting.
- The appliance is not to be used by persons (including children) with reduced physical, sensory or mental capabilities, or lack of experience and knowledge, unless they have been given supervision or instruction.
- Children being supervised not to play with the appliance.



PREMIER UNDERCOUNTER

- Cleaning and user maintenance shall not be made by children without supervision.
- This appliance can be used by children aged from 8 years and above and persons with reduced physical, sensory or mental capabilities or lack of experience and knowledge if they have been given supervision or instruction concerning use of the appliance in a safe way and understand the hazards involved.
- Any electrical or mechanical changes to this cabinet will void the warranty. Changes carried out by non-authorized service engineers and changes other than those described in this manual will also void the warranty. The manufacturer will not accept any responsibility for damages arising from such changes.

CLIMATE CLASS

The cabinet is designed to run within specific ambient temperature and humidity levels. These are set out in the climate class system. These levels are never to be exceeded. The climate class for this product can be found on the product description label. The refrigerator is not suitable for use in temperatures below 16 °C ambient temperature.

Climate Class	Ambient Temperatures and Humidity
4	+30°C with %55 RH
5	+40°C with %40 RH

FIRST ACCEPTANCE AND CONTROLS

This cabinet was packed in protective packaging material for shipping. On delivery, please check the cabinet for any possible transport damage and that the cabinet model is what you ordered.



IMPORTANT

All operations listed below must fully comply with all local bylaws and safety regulations. Observe all current safety rules when operating this product.

TRANSPORTING

When lifting the product using machinery, the lifting capacity of any machinery must be verified prior to undertaking any such procedures.



IMPORTANT

When using a fork truck to move the product, please ensure that the forks are inserted into the appropriate openings in the pallet.

Once moving, attention must be paid to the stability of the product. If the centre of gravity is not central to the product, which will make it prone to tip over. When lowering the product with a fork truck ensure this is done slowly and with care.



ATTENTION

Recommendations written on the outside of the transport packaging are for the user's benefit. Therefore the following recommendations should be observed:

- Carry the product carefully.
- Keep the product dry. Do not use the top of the cabinet for storage.



PREMIER UNDERCOUNTER

OPENING THE PACKAGING

- Remove the cardboard and any other packaging material.
- Lift the cabinet to disconnect and remove it from the pallet.
- Place the cabinet in the desired location, standing on its own base.
- Check for any visible damage. Packaging materials can be recycled according to local recycling regulations.
- Verify that the product code and serial number match the same on any shipping documents.

Trademark			HOSHIZAKI			
Model name			PREMIER F 2 A DL DR	PREMIER K/M 2 A DL DR	PREMIER K/M 2 A 2D 2D	PREMIER K/M 2 A 3D 3D
Intended use			Storage	Storage	Storage	Storage
Chilled operating temperature				X	X	X
Frozen operating temperature			X			
Multiuse cabinet						
Vertical cabinet						
Counter cabinet			X	X	X	X
Parameter	Symbol	Unit				
Energy Efficiency Class	EEC	-	C	A+	A	A
Energy Efficiency Index	EEl	-	40,26	13,9	17,42	17,85
24 hours Energy Consumption	E24h	kWh	3,862	0,869	1,069	1,069
Annual Energy Consumption	AEC	kWh	1410	317	390	390
Net volume for compartment 1	Vn1	litre	96	96	88	77,5
Net volume for compartment 2	Vn2	litre	96	96	88	77,5
Net volume for compartment 3	Vn3	litre	-	-	-	-
Net volume for compartment 4	Vn4	litre	-	-	-	-
Total Net volume	VnT	litre	192	192	176	155
Climate Class	CC		5	5	5	5
Refrigerant			R290	R600a	R600a	R600a
Charge		kg	0.055	0.07	0.07	0.07
GWP			3	3	3	3
CO2 Equivalent		CO ₂	0,165	0,21	0,24	0,21
Heavy-duty; This appliance is intended for use in ambient temperatures up to 40°C			X	X	X	X
Contact details:	HOSHIZAKI EUROPE B.V.					
	Address: Burgemeester Stramanweg 101 1101 AA Amsterdam, The Netherlands Tel.: +31 (0)20 691 84 99 - http://hoshizaki.europe.com/					

HOSHIZAKI

PREMIER UNDERCOUNTER



Trademark			HOSHIZAKI			
Model name			PREMIER F 3 A DL DL DR	PREMIER K/M 3 A DL DL DR	PREMIER K/M 3 A 2D 2D 2D	PREMIER K/M 3 A 3D 3D 3D
Intended use			Storage	Storage	Storage	Storage
Chilled operating temperature				X	X	X
Frozen operating temperature			X			
Multiuse cabinet						
Vertical cabinet						
Counter cabinet			X	X	X	X
Parameter	Symbol	Unit				
Energy Efficiency Class	EEC	-	C	A	A	A
Energy Efficiency Index	EEI	-	47,98	18,77	21,29	22,02
24 hours Energy Consumption	E24h	kWh	5,340	1,299	1.438	1.438
Annual Energy Consumption	AEC	kWh	1949	474	525	525
Net volume for compartment 1	Vn1	litre	96	96	88	77,5
Net volume for compartment 2	Vn2	litre	96	96	88	77,5
Net volume for compartment 3	Vn3	litre	96	96	88	77,5
Net volume for compartment 4	Vn4	litre	-	-	-	-
Total Net volume	VnT	litre	288	288	264	232
Climate Class	CC		5	5	5	5
Refrigerant			R290	R290	R290	R290
Charge		kg	0.055	0.065	0.065	0.065
GWP			3	3	3	3
CO2 Equivalent		CO ₂	0,165	0,195	0,195	0,195
Heavy-duty; This appliance is intended for use in ambient temperatures up to 40°C			X	X	X	X
Contact details:	HOSHIZAKI EUROPE B.V.					
	Address: Burgemeester Stramanweg 101 1101 AA Amsterdam, The Netherlands Tel.: +31 (0)20 691 84 99 - http://hoshizaki.europe.com/					

HOSHIZAKI

PREMIER UNDERCOUNTER



Trademark			HOSHIZAKI			
Model name			PREMIER F 4 A DL DL DR DR	PREMIER K/M 4 A DL DL DR DR	PREMIER K/M 4 A 2D 2D 2D 2D	PREMIER K/M 4 A 3D 3D 3D 3D
Intended use			Storage	Storage	Storage	Storage
Chilled operating temperature				X	X	X
Frozen operating temperature			X			
Multiuse cabinet						
Vertical cabinet						
Counter cabinet			X	X	X	X
Parameter	Symbol	Unit				
Energy Efficiency Class	EEC	-	C	A	A	A
Energy Efficiency Index	EEl	-	44,77	17,37	21,87	22,79
24 hours Energy Consumption	E24h	kWh	5,67	1,319	1,612	1,612
Annual Energy Consumption	AEC	kWh	2070	481	588	588
Net volume for compartment 1	Vn1	litre	96	96	88	77,5
Net volume for compartment 2	Vn2	litre	96	96	88	77,5
Net volume for compartment 3	Vn3	litre	96	96	88	77,5
Net volume for compartment 4	Vn4	litre	96	96	88	77,5
Total Net volume	VnT	litre	384	384	352	310
Climate Class	CC		4	5	4	4
Refrigerant			R290	R290	R290	R290
Charge		kg	0.055	0.065	0.065	0.065
GWP			3	3	3	3
CO2 Equivalent		CO ₂	0,165	0,195	0,195	0,195
Heavy-duty; This appliance is intended for use in ambient temperatures up to 40°C				X		
Contact details:	HOSHIZAKI EUROPE B.V.					
	Address: Burgemeester Stramanweg 101 1101 AA Amsterdam, The Netherlands Tel.: +31 (0)20 691 84 99 - http://hoshizaki.europe.com/					

HOSHIZAKI

PREMIER UNDERCOUNTER



II. OPERATING INSTRUCTIONS

ELECTRICITY

Before connecting the product to electrical power, please verify that the specified electrical power supply on the product description label corresponds with the local network electrical power supply.

The Product Description label with the specified electrical power supply can be found on the inside of the cabinet, at the top left-hand side.

Installation of the product must only be undertaken by qualified and trained service personnel as per the specifications listed in this manual.

Electrical safety of this cabinet can only be valid if it's earthed in accordance to current local laws and regulations.

Earthing of the product is always required.

The manufacturer will not accept any responsibility for any damage arising from improper grounding.

Adhere to all electricity requirements stipulated by the local electrical regulations. The product's electricity plug, and wall socket must have the correct earth connectivity reading. If necessary, employ a qualified electrician.

GENERAL PRELIMINARY CHECKS

Make sure the cabinet is standing on level ground. All legs/castors should be on the ground. This is necessary for the proper operation of the cabinet.

Do not place the cabinet next to any heat generating devices such as ovens, grills, and deep fryers. Do not expose to direct sun light. Heat that may be radiated by walls or floors must be insulated with appropriate insulating material. The cabinet should be placed as far as possible from any heat source.

If the cabinet is re-located, allow three hours before re-starting. Plastic protection or tape should be removed from the outer surfaces.

Ensure the cabinet is positioned so sufficient fresh air can flow to/from the cooling circuit and around the surfaces of the cabinet.

If two refrigerators or freezers are to be placed side by side, there should be at least 50 mm. space between them.

Do not block any vent holes.

PRELIMINARY ELECTRICAL CHECKS

- Check that the mains voltage and frequency of the socket conform to the information on the product description label.
- The cabinet is connected to a mains outlet with a 13-16 Amp fuse as a serial connection.
- Turn off the mains fuse connected to the power cable.
- Check that the plug on the cabinet is suitable for use with the available mains socket and that they fit together.

HOSHIZAKI

PREMIER UNDERCOUNTER



FIRST OPERATIONS AND CONTROLS

After the above checks have been completed, the cabinet can be operated. The ON/OFF switch operates the cabinet.

After the cabinet is turned ON, the compressor will start running. The compressor will run until the factory pre-set temperature is reached. Foods should not be placed in the cabinet until the temperature setting has been adjusted to suit the foods to be cooled.

New temperature setting can be done through the controller as described in this manual.



IMPORTANT

- Allow the product to cool to the set temperature before placing food items inside.
- Never exceed the maximum load capacity. The maximum shelf capacity is an even load of 40 kg each for shelves in upright cabinets and 20 kg for shelves and drawers in counter cabinets.
- Refer to the “General Preliminary Checks’ section of this manual for information on the amount of space required for good air ventilation around the product.
- Do not store explosive substances such as aerosol cans with a flammable propellant in this appliance.
- **In case of 1/3 drawer, Container lid with seal equipment cannot be used.**

WARNING:

- Do not block any ventilation openings on the appliance at any time.
- Do not use mechanical devices or other means to accelerate the defrosting process, other than those recommended by the manufacturer.
- Do not damage the refrigerant circuit.
- Do not use electrical appliances inside the cabinet.
- Do not damage powercord, wiring or any key component.

STORAGE CONDITIONS AND PERFORMANCE

Correct storage conditions are not only paramount to food hygiene and safety but improve the quality of service and reduce the energy consumption. Best performance can be achieved if the following tips and guidelines are observed. Keep all food items on shelves only and never place food items on the floor of the cabinet. Food items must be placed in the cabinet or counter in such a way as to allow good air flow all around, leaving space between items and the walls of the product. If required shelf distance can be adjusted accordingly.



III. CONTROL PANEL

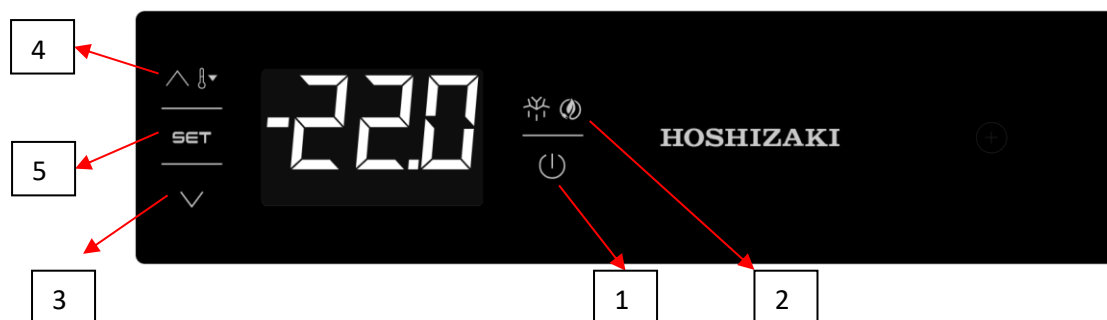

➤ FRONT PANEL FUNCTIONS

To lock the front panel keys, hold AUX (3) and hold On / Stand By (1) for 2 seconds: "Loc" text will be on the screen when keys are locked, if it isn't locked, "UnL" text will be on the screen.

1) When holding **ON/STAND BY** for 4 seconds; the device opens or closes. (On/Off)

2) **MANUAL DEFROST**; if the button is pressed for 4 seconds, manual defrost starts. If excessive cooling is active and evaporator temperature is not suitable, manual defrost will not start.

3) **DOWN** key: Scroll down the menu or reduce the value; if held down for 4 seconds super cooling becomes active. When an excessive cooling function is active, the set temperature can be reduced; the time and temperature are determined with the help of the parameters. When an excessive cooling function is activated, the device never does defrost.

4) **UP** Key: Scroll up the menu or increase the value; if held down for 4 seconds, the percentage of low and high relative humidity function is engaged. (For some models) "rhL" is written on the screen (A low percentage of relative humidity function is operating.) or "rhH" is written on the screen (A high percentage of relative humidity function is operating.) These functions appear on the screen for 10 seconds. If humidity control is not available, "----" appears on the screen for 1 second.

5) **SET** key: input and change key for adjustable values.

➤ OPERATING

Operation cases are available below:

"On" status: The device is energized and the device operates.

"Stand-By" status: The device is switched off, but the device is still powered.

"Of" status: To turn the device off, remove the plug from the socket, or by turning the main fuse off, the device is turned off.

HOSHIZAKI

PREMIER UNDERCOUNTER



IV. MAINTENANCE INSTRUCTIONS

The device must be cleaned regularly. The intervals depend on the usage and level of soiling (at least annually).



Before carrying out any cleaning or maintenance operations, unplug the unit.



Don't touch or wet the machine compartment parts. This could result in failure or breakdown.



To prevent possible damage, don't clean the plastic parts with water above 40° C or in a dishwasher.

Interior & Exterior of Cabinet and Shelves



Clean the interior and exterior at least once a week for sanitary use.



Clean off the interior and exterior of cabinet with a soft cloth soaked in cold or warm water containing the proper amount of neutral cleaner and wrung dry. Don't use a water jet to clean the machine compartment.



Chemical agents other than neutral cleaner might cause damage to the interior and exterior surfaces.



Any remaining detergent will damage metal or plastic surfaces. Use a soft cloth dampened with warm water to wipe it off.



Don't use the following items, they could damage painted or plastic surfaces:

- Polishing powder, alcohol, thinner, benzene, acidic or alkaline detergent, hot water, petroleum, soap powder, metal scourer or brush, etc. Especially detergent to clean grease on ventilator or microwave.



Note: Some solutions other than the above may also damage painted or plastic surfaces. Immediately stop using such solutions if they cause any problems!



The door gasket and its contact surface get soiled easily. Clean every surface of these parts thoroughly. Remnants of food will accelerate aging.



PREMIER UNDERCOUNTER

Use a cloth to wipe off any water staying inside the cabinet.

Condenser



Use vacuum cleaner or a soft brush to remove dust and stains from the condenser.



Warning: If user clean the condenser with hard brush, such as dishwasher brush, the coating of condenser may peel off.

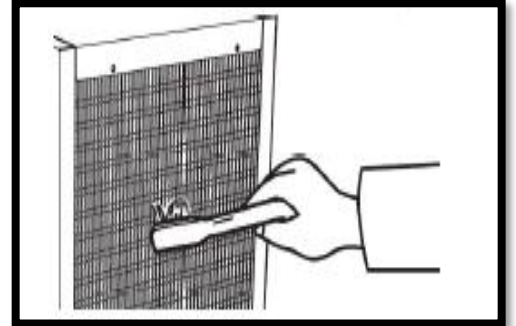

Air Filter



To prevent deformation do not wash the air filter hot water above 40°C.



Plastic mesh air filters remove dirt or dust from the air and keep the condenser from getting clogged. If the filters get clogged, the refrigerator/freezer's performance will be reduced.



Check the filters at least twice a month. When clogged or when the temperature controller shows "cH" use warm water and a neutral cleaner to wash the filters. Don't operate the unit with the air filters removed, or the condenser will get clogged, resulting in failure.

- 1) Open the front panel and remove the air filter. To prevent injury, don't touch the condenser fins directly.
- 2) Wash the air filter carefully with cold or warm water containing the proper amount of neutral cleaner. Rinse and dry the air filter thoroughly.
- 3) To refit the air filter put the two tabs into the heat exchanger or fins in a condenser and tightly attach the air filter over the condenser.

PREMIER UNDERCOUNTER

V. TECHNICAL INFORMATION

DIMENSIONS OF THE DEVICES

PREMIER K-M-F 2 A DL DR L

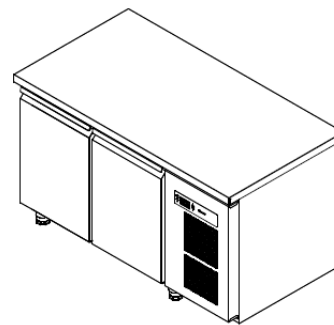
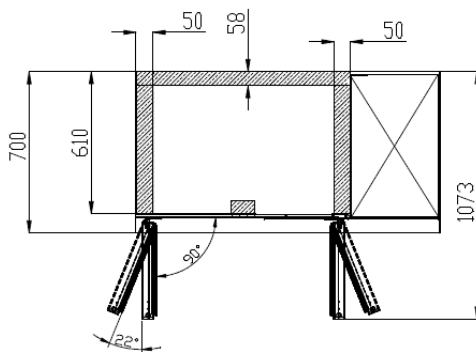
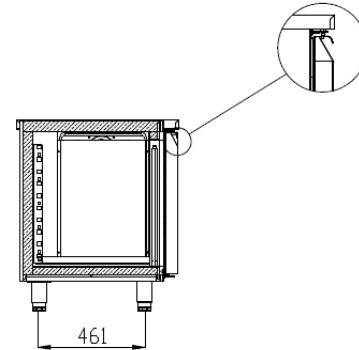
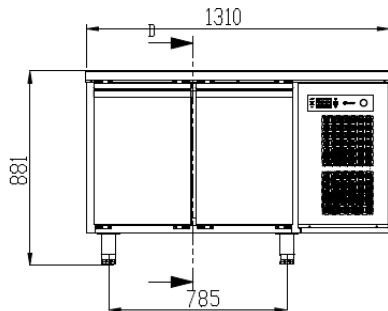

PREMIER K-M-F 2 A DL DR C

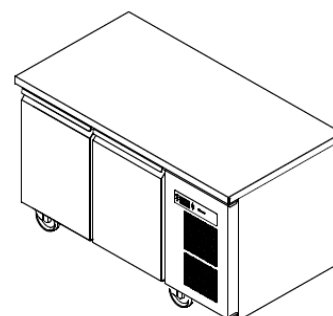
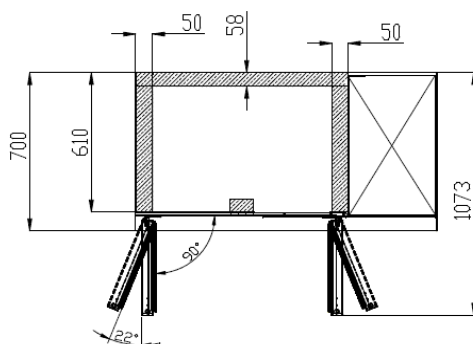
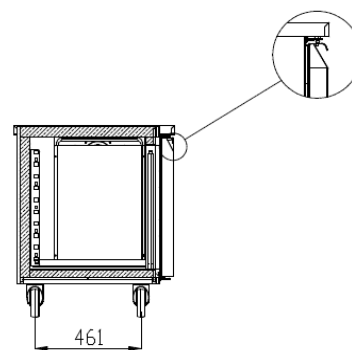
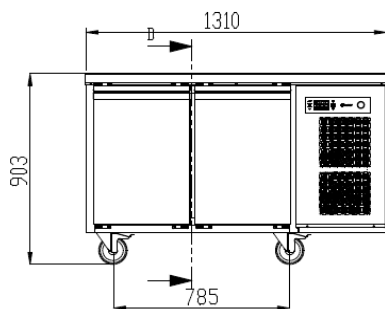

PREMIER UNDERCOUNTER

PREMIER K-M 2 A 2D 2D L

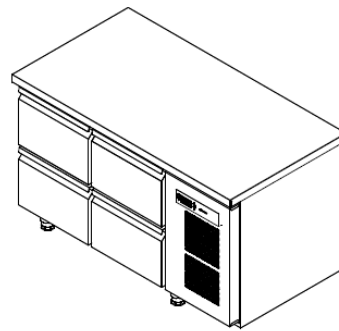
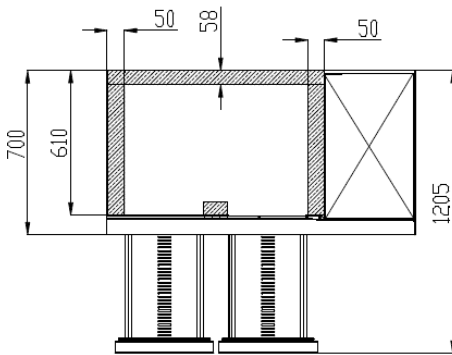
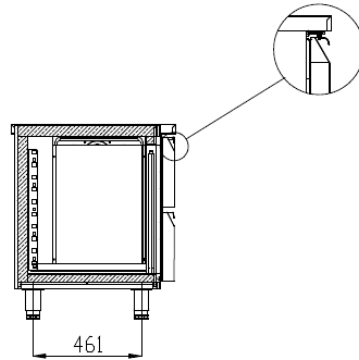
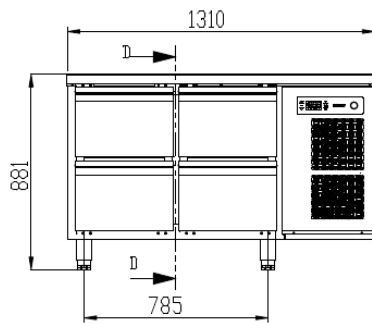

PREMIER K-M 2 A 2D 2D C

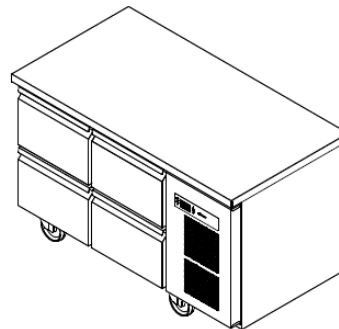
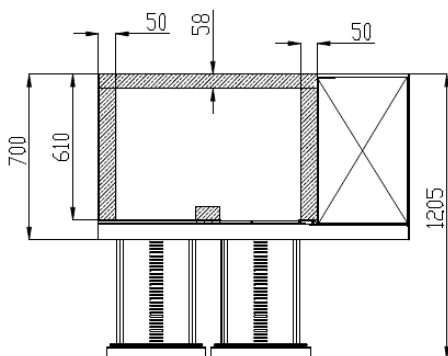
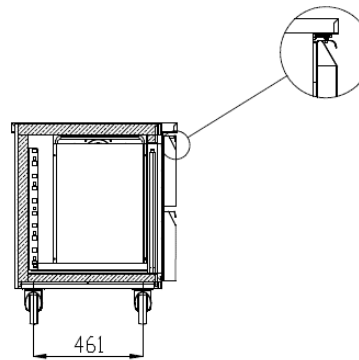
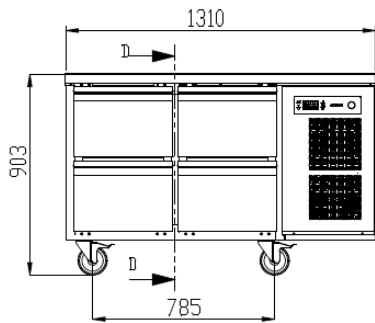

HOSHIZAKI



PREMIER UNDERCOUNTER

PREMIER K-M 2 A 3D 3D L

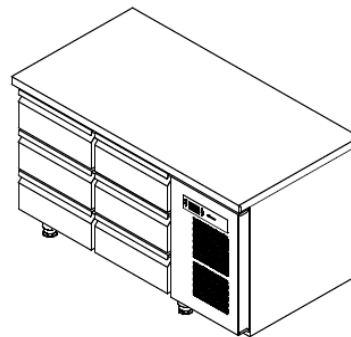
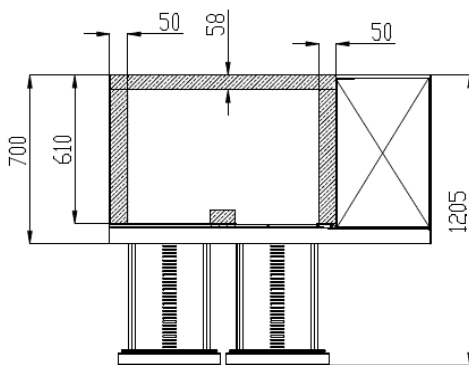
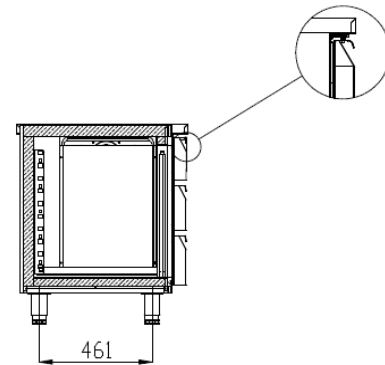
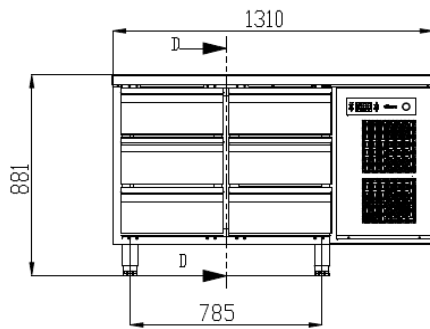

PREMIER K-M 2 A 3D 3D C

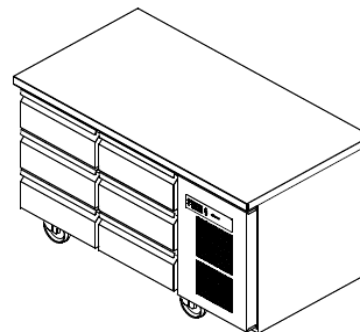
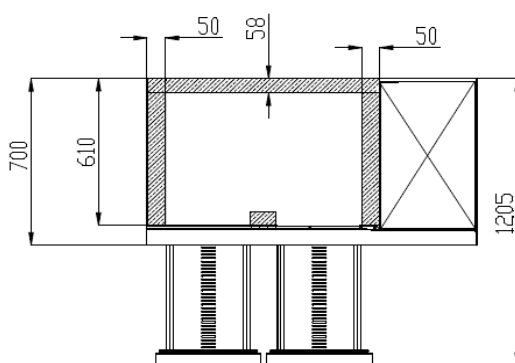
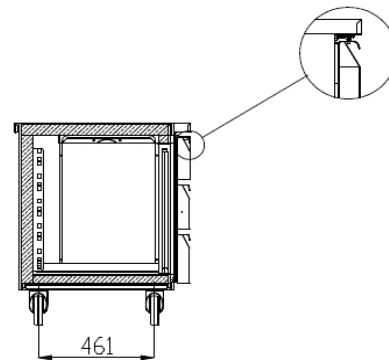
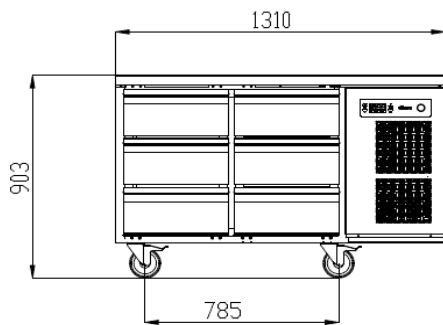

PREMIER UNDERCOUNTER

PREMIER K-M-F 3 A DL DR DR L

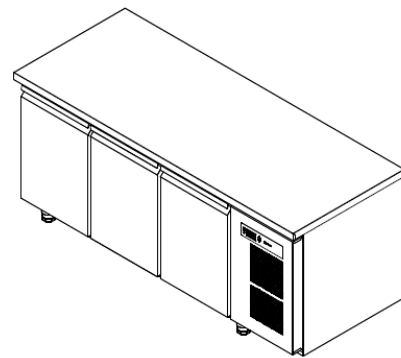
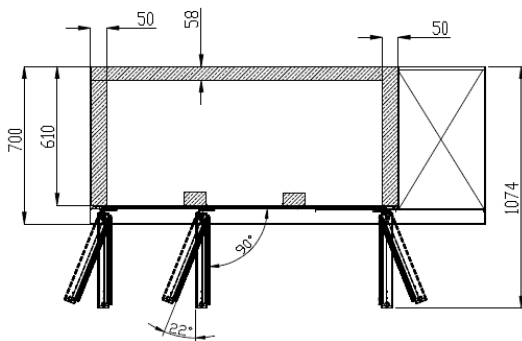
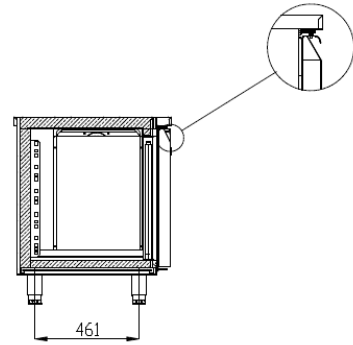
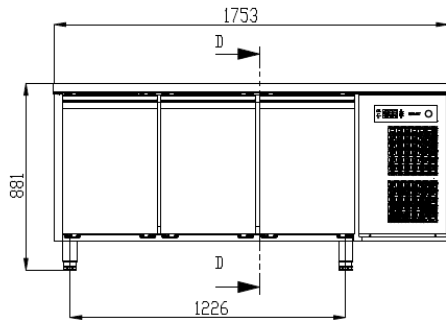

PREMIER K-M-F 3 A DL DR DR C

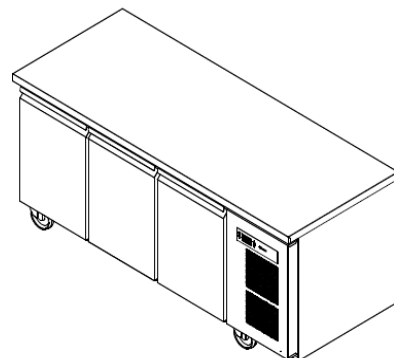
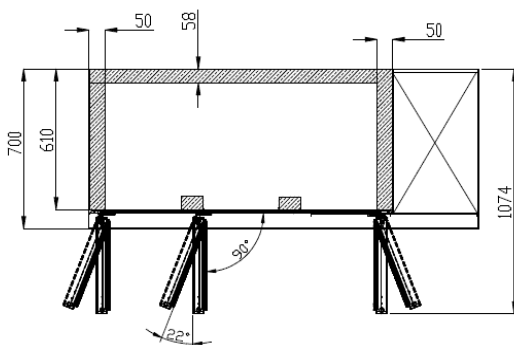
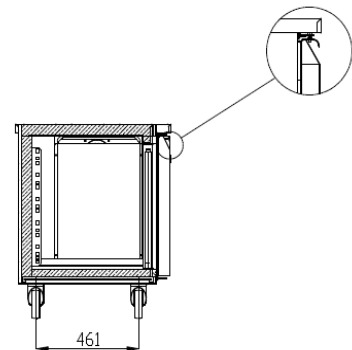
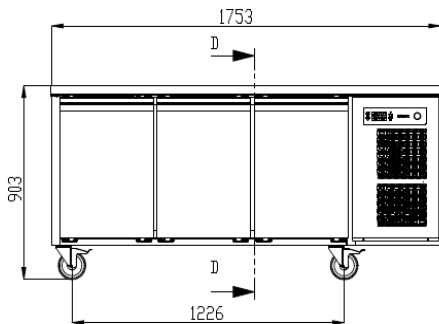

HOSHIZAKI



PREMIER UNDERCOUNTER

PREMIER K-M 3 A 2D 2D 2D L

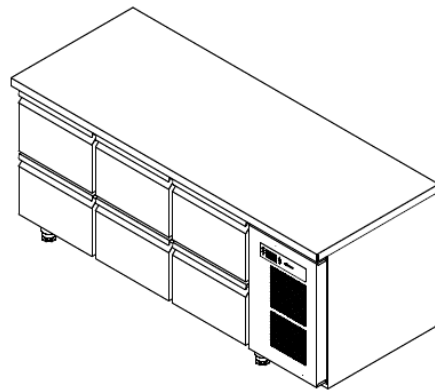
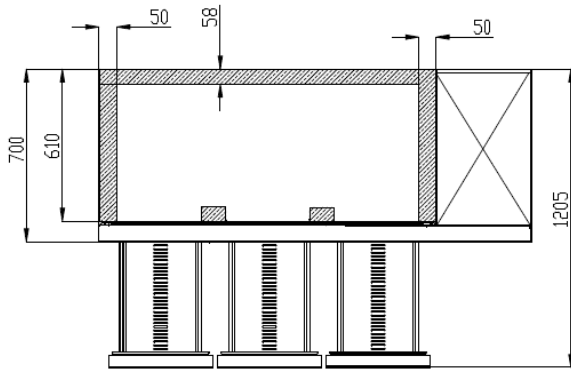
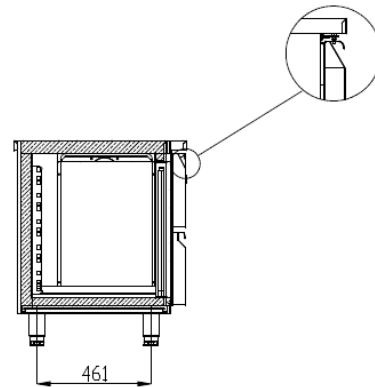
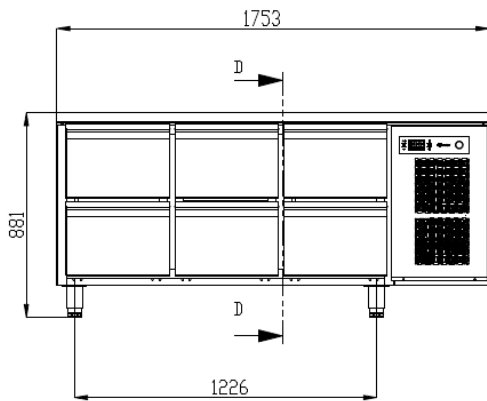

PREMIER K-M 3 A 2D 2D 2D C

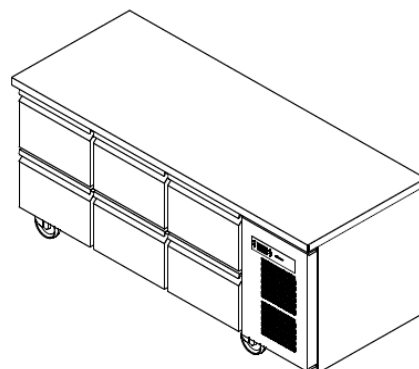
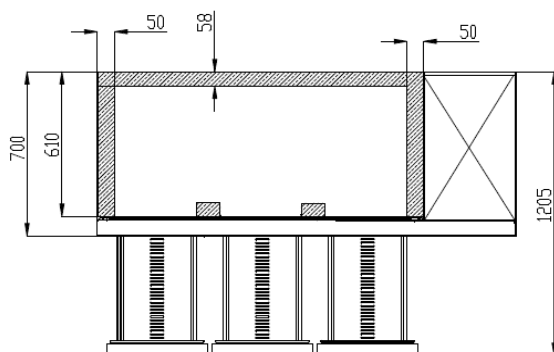
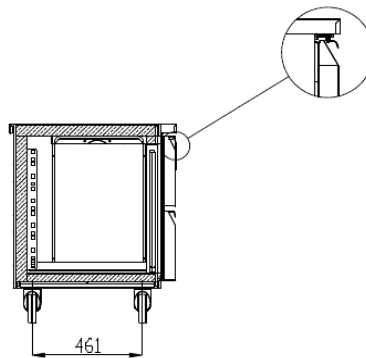
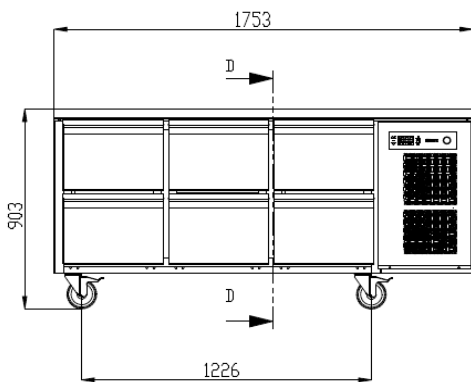

PREMIER UNDERCOUNTER

PREMIER K-M 3 A 3D 3D 3D 3 L

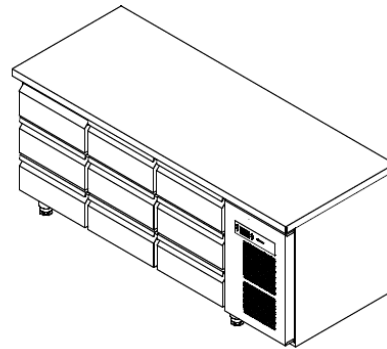
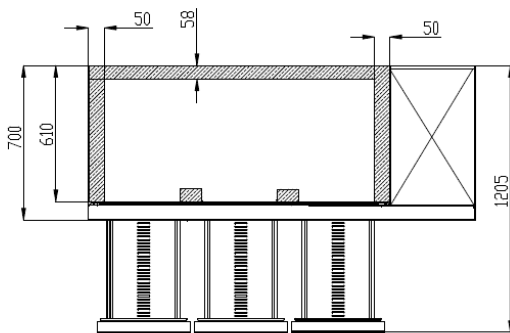
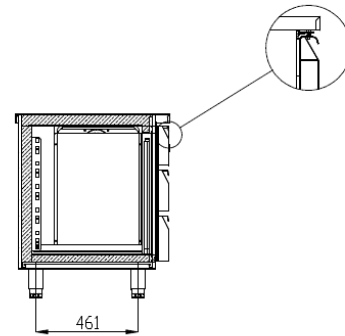
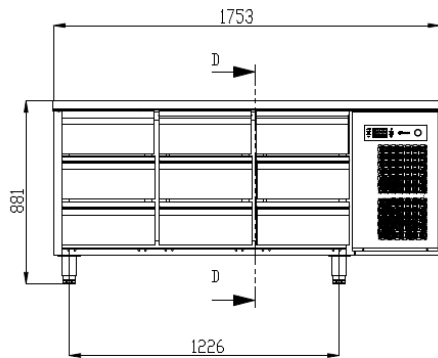

PREMIER K-M 3 A 3D 3D 3D C

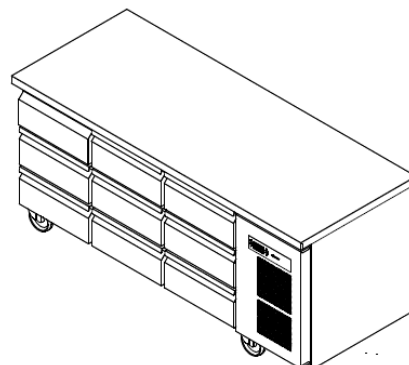
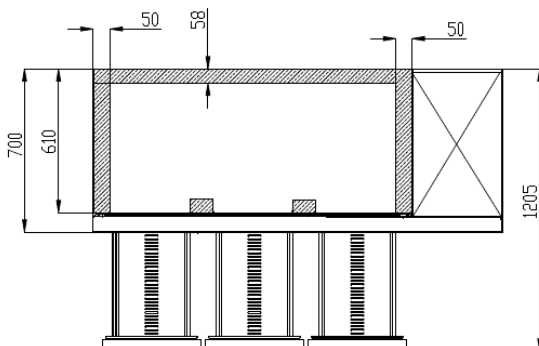
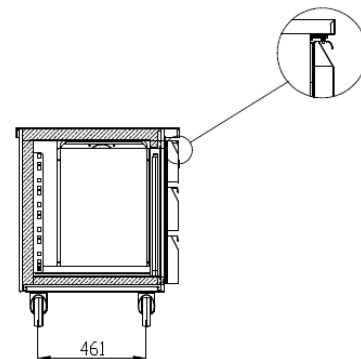
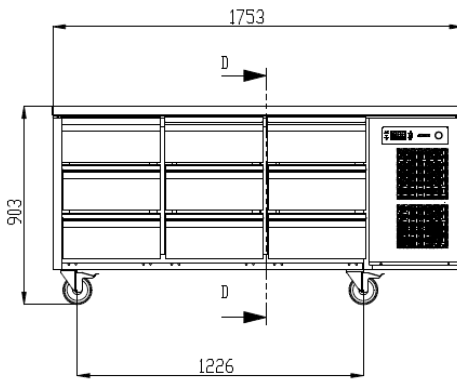

PREMIER UNDERCOUNTER

PREMIER K-M-F 4 A DL DL DR DR L

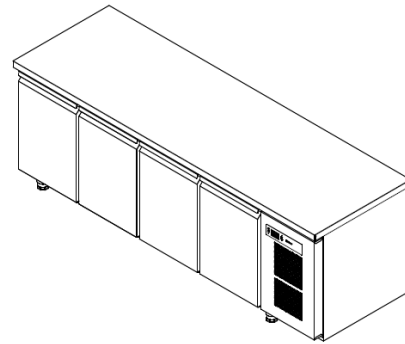
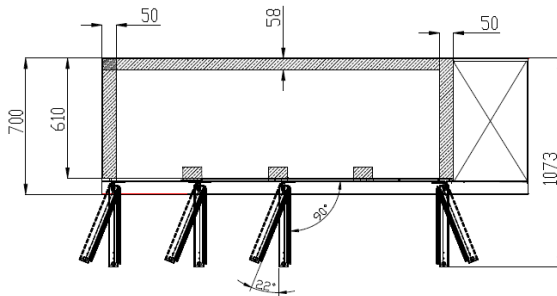
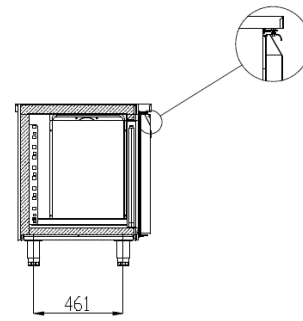
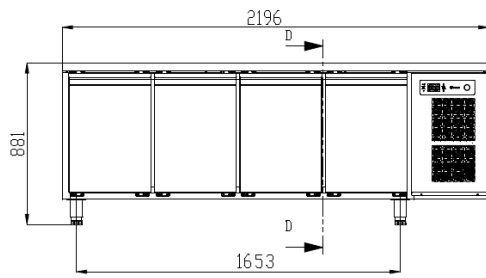

PREMIER K-M-F 4 A DL DL DR DR C

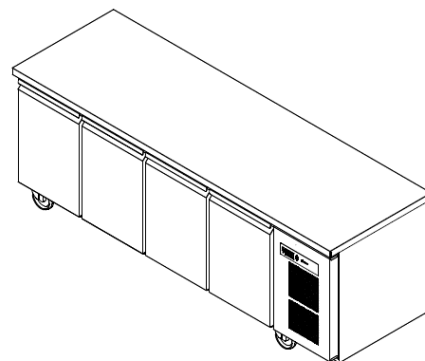
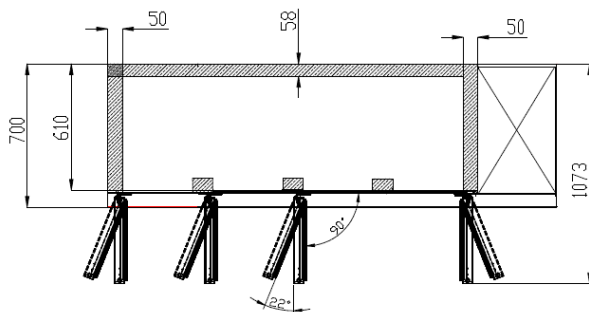
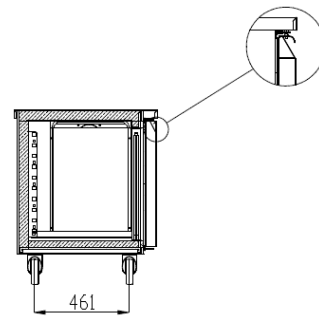
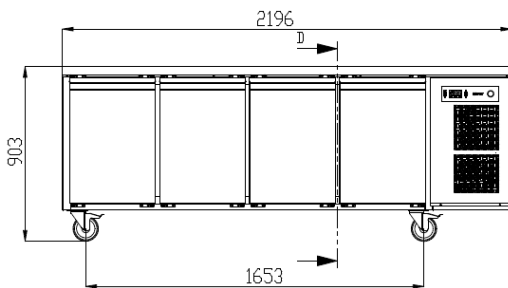

PREMIER UNDERCOUNTER

PREMIER K-M 4 A 2D 2D 2D 2D L

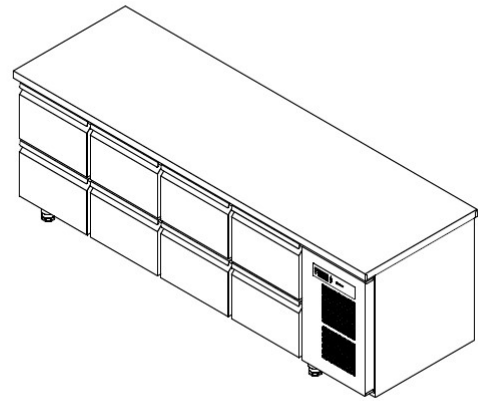
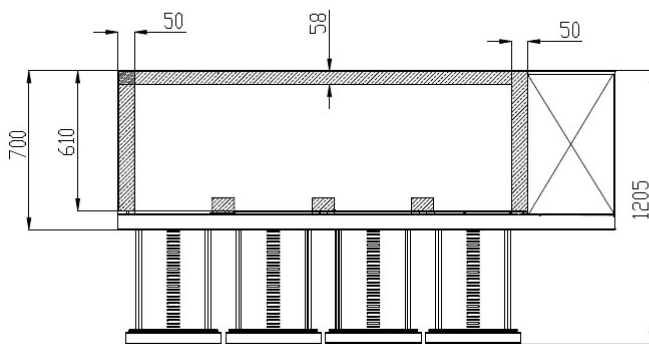
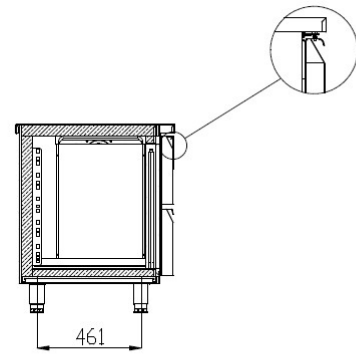
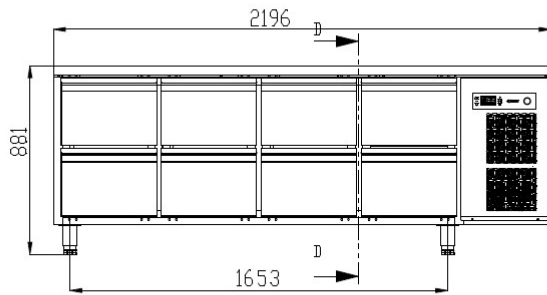

PREMIER K-M 4 A 2D 2D 2D 2D C

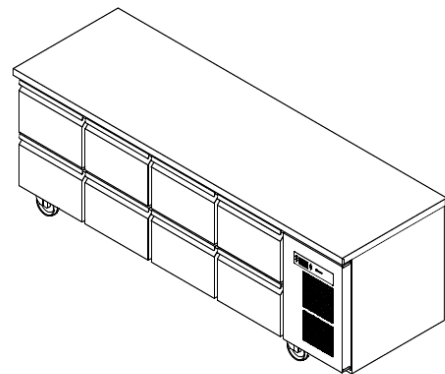
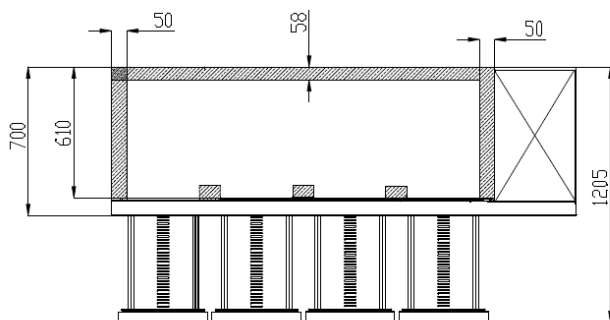
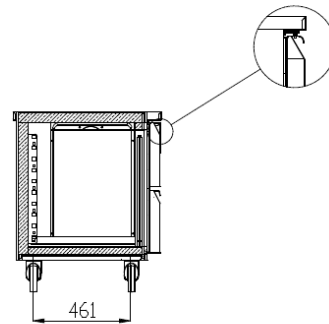
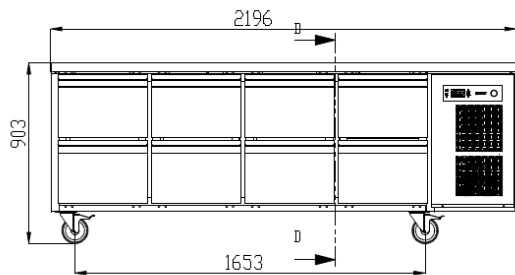

HOSHIZAKI

PREMIER UNDERCOUNTER



PREMIER K-M 4 A 3D 3D 3D 3D L

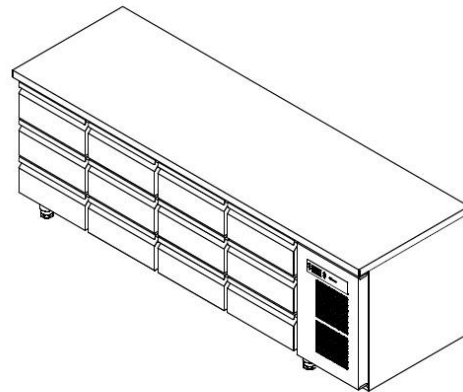
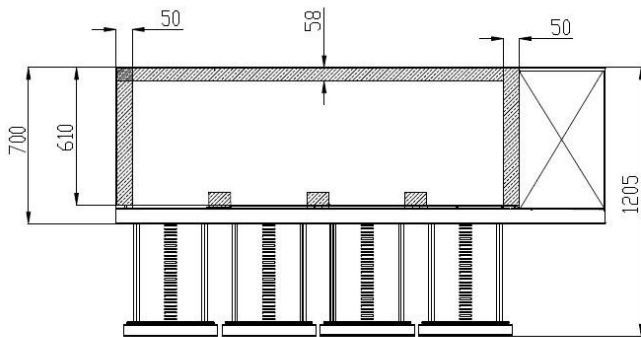
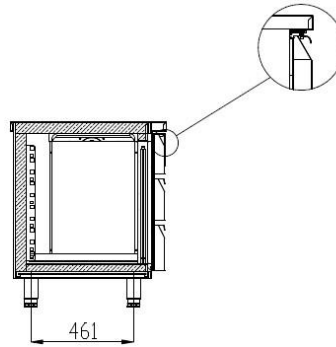
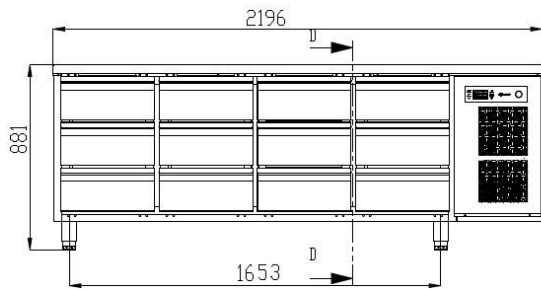

PREMIER K-M 4 A 3D 3D 3D 3D C

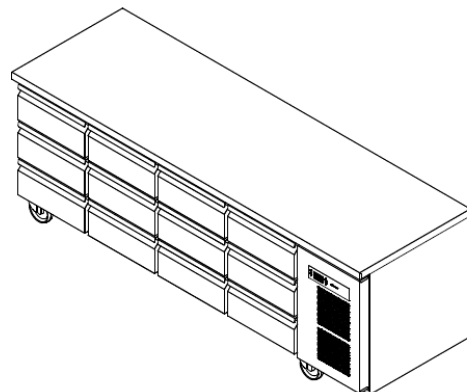
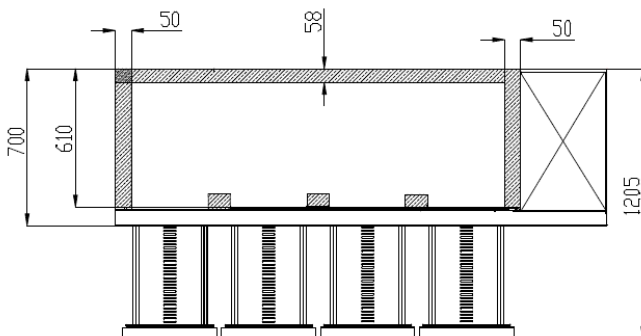
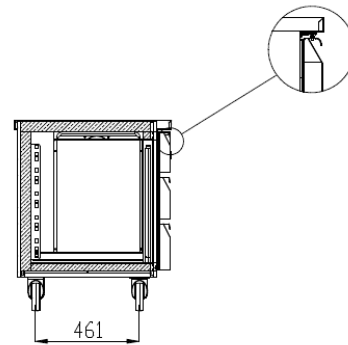
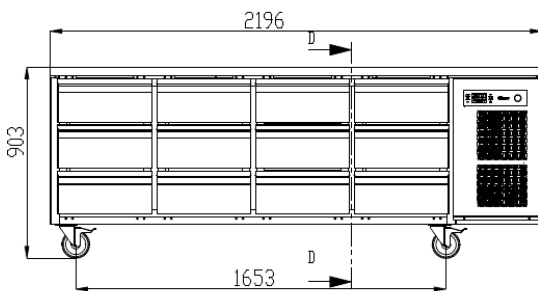

PREMIER UNDERCOUNTER

VI. COOLING DIAGRAM – ELECTRICAL WIRING DIAGRAM

COOLING DIAGRAM

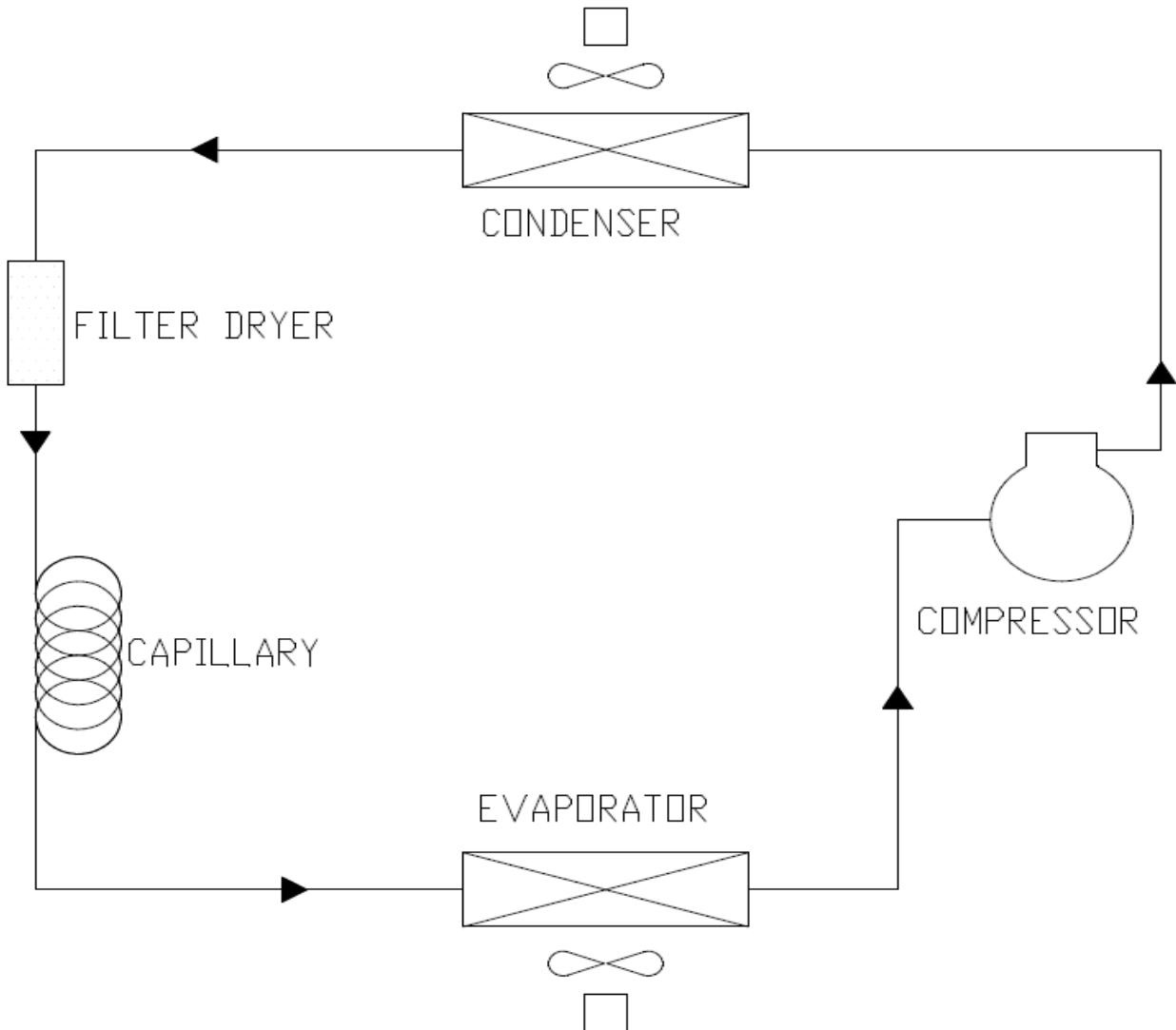

HOSHIZAKI

PREMIER UNDERCOUNTER



ELECTRICAL WIRING DIAGRAM (FOR CABINET REFRIGERATOR & FREEZER MODELS)

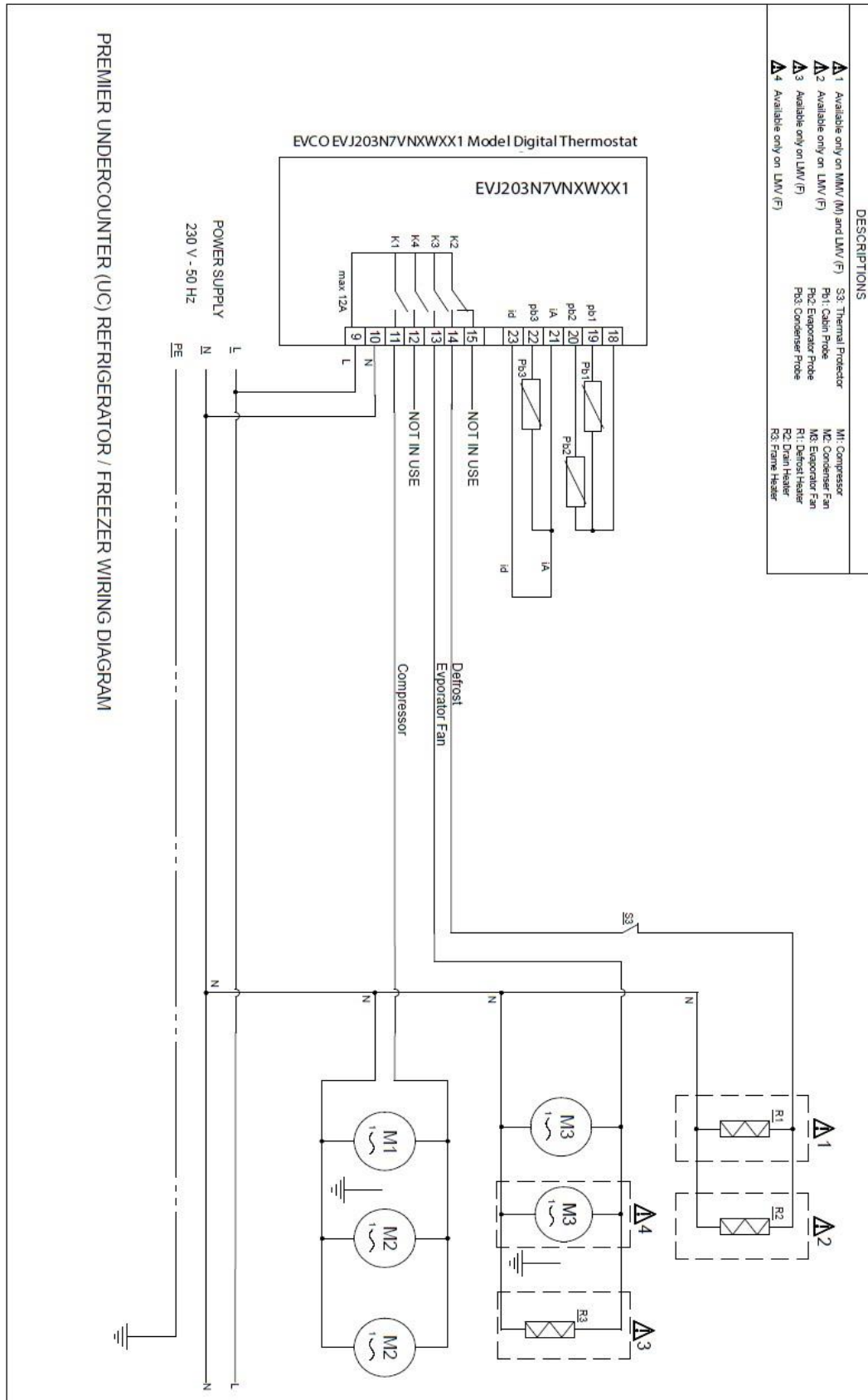



PREMIER UNDERCOUNTER

VII. SERVICE DIAGNOSIS

The table below lists several problems that you may encounter. If an alarm code is displayed, a malfunction has occurred. Please correct any possible causes before resetting the cabinet. Potential causes and remedies are listed below.

If an error code persists after you have carried out the checks below, please contact an authorized technician. The characteristics of the error message must be determined. Product details including the serial number can be found on the nameplate of the product.

PROBLEM	POSSIBLE CAUSE	REMEDY	
The counter is not working	No power is supplied to cabinet	Check the power plug and cable are fault free	
The compressor seldom stops running	Ambient temperature is too high	Ventilation needs to be improved	
	Condenser are blocked	Check and clean condenser regularly	
	Door gaskets are not sealing properly	Call authorized technician to replace seals	
	Evaporator is iced up	Do not place hot food items in the cabinet	Do not place food items with high water content inside cabinet unless they are stored in sealed containers
		Start a manual defrosting cycle	
Evaporator fan/fans are faulty	Call authorized technician to replace the fan/fans		
Overflowing water from the condenser water tray	Frequent placement of hot food items in the cabinet	Do not place hot food items in the cabinet	
		Only place food items with high water content in sealed containers in the cabinet	
	Frequent opening of door or drawers	Verify whether cabinet specifications confirm it is suitable for current usage	
Cabinet temperature is high	Condenser is blocked with dirt and dust	Check and clean condenser regularly	
	Air flow within cabinet is blocked	Remove items of food blocking the air flow	
	Ambient air is entering cabinet	Ensure door is closed	Check for damage to the door and drawer seals
		Contact an authorized technician	
Evaporator is iced up	Start a manual defrosting cycle		



PREMIER UNDERCOUNTER

VIII. REMOVAL AND REPLACEMENT

DISPOSING OF THE CABINET

- The cooling gas present in the cabinet can be identified from the nameplate.
- The cabinet is produced from recyclable materials in accordance with EU regulations. Therefore, at the end of its economic life, the cabinet must be passed to the appropriate recycling centre for disposal.
- Do not recycle the cabinet as metal or household waste.
- Do not compact the cooling plant refrigeration circuit.



IMPORTANT

Adhere to local by-laws and regulations during disposal of the cabinet.

HOSHIZAKI

PREMIER UNDERCOUNTER



All Rights Reserved

Hoshizaki reserves the right to change any features and the information in this manual.

Contact Details

Headquarters

Hoshizaki Europe B.V – All other countries in Europe and Africa

TEL: +31 (0)20 6918499

sales@hoshizaki.nl -- <http://hoshizaki-europe.com/>

Branches

Hoshizaki UK - UK, Ireland

TEL: +44 (0)845 456 05 85

uksales@hoshizaki.co.uk

Hoshizaki Deutschland - Germany, Switzerland, Austria

TEL: +49 (0)5121 697370

vertrieb@hoshizaki.de

Hoshizaki Benelux - Netherlands, Belgium, Luxembourg

TEL: +31 (0)85 0188370

info@hoshizaki.nl

Hoshizaki France - France

TEL: +33 (0)1 48 63 93 80

info@hoshizaki.fr

Hoshizaki Iberia - Spain, Portugal

TEL: +34 (0)93 478 09 52

info@hoshizaki.es

Hoshizaki Denmark - Denmark

TEL: +45 89 88 53 50

salg@hoshizaki.dk

Hoshizaki Norway - Norge

TEL: +47 22 88 17 50

salg@hoshizaki.no

Hoshizaki Sweden - Sverige

TEL: +46 108 84 87 47

OrderSE@hoshizaki.dk

Hoshizaki Italia – Italia

TEL: +39 348 3022156

commerciale@hoshizaki.it

HOSHIZAKI

PREMIER UNDERCOUNTER



HOSHIZAKI

PREMIER UNDERCOUNTER



REFRIGERATEURS ET CONGELATEURS

MANUEL D'UTILISATION, D'ENTRETIEN ET D'INSTALLATION



I. INFORMATIONS GÉNÉRALES	28
II. CONSIGNES D'UTILISATION	33
III. PANNEAU DE CONTROLE	35
IV. INSTRUCTIONS D'ENTRETIEN	36
V. INFORMATIONS TECHNIQUES	38
VI. SCHEMA DE REFROIDISSEMENT – SCHEMA DE CABLAGE	47
VII. TABLEAU DE DIAGNOSTIC	49
VIII. DEPOSE ET REMPLACEMENT	50

Coordonnées :

HOSHIZAKI EUROPE B.V.

Adresse: Burgemeester Stramanweg 101 1101 AA Amsterdam, The Netherlands

Tel: +31 (0)20 691 84 99 - <http://hoshizaki-europe.com/>



HOSHIZAKI

PREMIER UNDERCOUNTER



I. INFORMATIONS GÉNÉRALES

ÉTIQUETTE DE DESCRIPTION DU PRODUIT

1 Numéro de produit
2 Description du produit
3 Modèle
4 Fluide frigorigène
5 Équivalent de CO ₂
6 Protection IP
7 Classe climatique
8 Date de production
9 Puissance totale/ Courant / puissance de la lampe
10 Tension - Fréquence
11 Élément chauffant
12 Pression du Système
13 Agent gonflant
14 Numéro de série

PRODUCT NUMBER	1
PRODUCT DESCRIPTION	2
MODEL	3
REFRIGERANT	4
CO ₂ EQUIVALENT	5
IP PROTECTION	6
CLIMATE CLASS	7
PRODUCTION DATE	8
TOTAL POWER / CURRENT / LAMP POWER	9
VOLTAGE - FREQUENCY	10
HEATING ELEMENT	11
SYSTEM PRESSURE	12
BLOWING AGENT	13

S/N: 14



HOSHIZAKI EUROPE B.V. Burgemeester Stramanweg 101 1101 AA
Amsterdam, The Netherlands



LE BUT DE L'UTILISATION

- Ce produit est adapté à une utilisation dans des espaces intérieurs seulement et uniquement dans le but de conserver des aliments et des boissons. Unités de stockage conçues pour maintenir le produit déjà à la température du réfrigérateur / congélateur.
- Le fabricant décline toute responsabilité pour tout dommage résultant d'une utilisation contraire à la directive indiquée dans ce manuel.
- En stockant les aliments dans ce réfrigérateur, il est nécessaire de s'assurer que la nourriture ne vient jamais en contact avec le corps de ce réfrigérateur.
- Tous les aliments doivent être complètement recouverts. Pour éviter la contamination et la corrosion des composants internes, tous les produits doivent être emballés ou stockés dans des conteneurs scellés.
- Ne pas stocker d'aliments ou de liquides chauds dans ce réfrigérateur.
- Les boissons conservées dans des boîtes et des bouteilles en verre ne doivent pas être conservées à des températures inférieures à 0 ° C (point de congélation). Les canettes et les bouteilles en verre peuvent éclater en raison de la dilatation. Tous les contenants avec couvercles ne doivent pas être remplis complètement, une petite quantité d'espace doit être laissée pour la dilatation.
- Ce réfrigérateur est équipé d'une installation d'auto-dégivrage automatique. Il est également possible d'effectuer un dégivrage manuel. Ce dégivrage manuel n'implique pas de fermer le réfrigérateur durant de longues périodes, mais peut être effectué via le contrôleur. En aucun cas la force ou des outils à main ne peuvent être utilisés pour dégivrer ce réfrigérateur, tout dommage résultant d'une telle action est difficile à réparer.
- N'employez aucun moyen mécanique ou autre de dégivrage.
- L'appareil ne doit pas être utilisé par des personnes (y compris des enfants) dont les capacités et capacités physiques, sensorielles ou mentales sont faibles ou qui ne sont pas disponibles d'une expérience et des connaissances suffisantes sans instruction ou supervision nécessaire.
- Les enfants sous surveillance ne doivent pas jouer avec l'appareil.
- Les processus de nettoyage et d'entretien des utilisateurs ne doivent pas être effectués par des enfants sans surveillance.

PREMIER UNDERCOUNTER

- Cette machine peut être utilisée par des enfants âgés de 8 ans et plus et par des personnes aux capacités physiques, sensorielles ou mentales réduites ou par des personnes dont l'expérience et les connaissances sont limitées dès lors qu'ils sont supervisés ou ont reçu des instructions relatives à l'utilisation de la machine en toute sécurité et qu'ils comprennent les dangers encourus.
- Toute modification électrique ou mécanique apportée à cette armoire annule la garantie. Les modifications apportées par des ingénieurs d'entretien non autorisés et les modifications autres que celles décrites dans le présent manuel annulent également la garantie. Le fabricant n'est en aucun cas responsable des dommages résultant de ces modifications.

CLASSE CLIMATIQUE

L'armoire est conçue pour fonctionner à des niveaux de températures ambiantes et d'humidité spécifiques. Ces niveaux sont définis dans le système de classe climatique. Ces niveaux ne doivent jamais être dépassés. La classe climatique de ce produit est indiquée sur la plaque signalétique du produit. Le réfrigérateur n'est pas adapté à une utilisation à des températures inférieures à une température ambiante de 16 °C.

Classe climatique	Températures ambiantes et humidité
4	+30 °C avec une HR de 55 %
5	+40 °C avec une HR de 40 %

PREMIERE ACCEPTATION ET CONTROLES

La présente armoire a été emballée dans un matériau d'emballage protecteur pour être expédiée. A la livraison, inspecter l'armoire pour vérifier l'absence de dommages dus au transport et vérifier que le modèle correspond à ce qui a été commandé.



IMPORTANT

Toutes les opérations répertoriées ci-dessous doivent respecter toutes les lois locales et les réglementations relatives à la sécurité. Respecter toutes les règles de sécurité en vigueur lorsque ce produit est utilisé.

TRANSPORT

Lorsque le produit est soulevé à l'aide de machines, la capacité de levage de toute machine doit être vérifiée avant d'entreprendre le levage.



IMPORTANT

Lorsqu'un chariot à fourches est utilisé pour déplacer le produit, s'assurer que les fourches sont insérées dans les orifices appropriés de la palette.

Une fois que le déplacement est commencé, il convient de faire attention à la stabilité du produit. Si le centre de gravité n'est pas au centre du produit, ce dernier est susceptible de basculer. Si le produit est abaissé à l'aide d'un chariot à fourches, vérifier que l'opération est effectuée lentement et prudemment.

Si des armoires verticales doivent être transportées à l'horizontale, s'assurer que l'armoire reste ensuite à la verticale pendant au moins 2 heures avant de l'utiliser. Il n'est pas recommandé de transporter des armoires verticales à l'horizontale et tout dommage résultant de cette opération n'est pas couvert par la garantie.

PREMIER UNDERCOUNTER



ATTENTION

Les recommandations écrites à l'extérieur de l'emballage de transport sont dans l'intérêt de l'utilisateur. Par conséquent, les recommandations suivantes doivent être respectées.

- Transporter le produit avec précaution.
- Maintenir le produit au sec. Ne pas utiliser le dessus de l'armoire comme zone de rangement.

OUVERTURE DE L'EMBALLAGE

- Retirer le carton et tout autre matériau d'emballage.
- Soulever l'armoire pour la détacher et la retirer de la palette.
- Positionner l'armoire à l'endroit souhaité, sur sa base.
- Inspecter l'armoire pour vérifier l'absence de dommages visibles.
- Les matériaux d'emballage peuvent être recyclés conformément à la réglementation locale en la matière.
- Vérifier que le code produit et le numéro de série sont identiques à ceux indiqués sur les documents d'expédition.

Trademark			HOSHIZAKI			
Model name			PREMIER F 2 A DL DR	PREMIER K/M 2 A DL DR	PREMIER K/M 2 A 2D 2D	PREMIER K/M 2 A 3D 3D
Intended use			Storage	Storage	Storage	Storage
Chilled operating temperature				X	X	X
Frozen operating temperature			X			
Multiuse cabinet						
Vertical cabinet						
Counter cabinet			X	X	X	X
Parameter	Symbol	Unit				
Energy Efficiency Class	EEC	-	C	A+	A	A
Energy Efficiency Index	EI	-	40,26	13,9	17,42	17,85
24 hours Energy Consumption	E24h	kWh	3,862	0,869	1,069	1,069
Annual Energy Consumption	AEC	kWh	1410	317	390	390
Net volume for compartment 1	Vn1	litre	96	96	88	77,5
Net volume for compartment 2	Vn2	litre	96	96	88	77,5
Net volume for compartment 3	Vn3	litre	-	-	-	-
Net volume for compartment 4	Vn4	litre	-	-	-	-
Total Net volume	VnT	litre	192	192	176	155
Climate Class			5	5	5	5
Refrigerant			R290	R600a	R600a	R600a
Charge			kg	0.055	0.07	0.07
GWP			3	3	3	3
CO2 Equivalent			CO ₂	0,165	0,21	0,24
Heavy-duty; This appliance is intended for use in ambient temperatures up to 40°C			X	X	X	X
Contact details:			HOSHIZAKI EUROPE B.V.			
			Address: Burgemeester Stramanweg 101 1101 AA Amsterdam, The Netherlands Tel.: +31 (0)20 691 84 99 - http://hoshizaki.europe.com/			

HOSHIZAKI

PREMIER UNDERCOUNTER



Marque commerciale			HOSHIZAKI			
Nom du modèle			PREMIER F 3 A DL DL DR	PREMIER K/M 3 A DL DL DR	PREMIER K/M 3 A 2D 2D 2D	PREMIER K/M 3 A 3D 3D 3D
Usage prévu			Storage	Storage	Storage	Storage
Température de réfrigération				X	X	X
Température de congélation			X			
Armoire polyvalente						
Armoire verticale						
Comptoir réfrigéré			X	X	X	X
Paramètre	Symbol	Unit				
Classe d'efficacité énergétique	EEC	-	C	A	A	A
Indice d'efficacité énergétique	EEl	-	47,98	18,77	21,29	22,02
Consommation énergétique sur 24 h	E24h	kWh	5,340	1,299	1.438	1.438
Consommation énergétique annuelle	AEC	kWh	1949	474	525	525
Volume net pour le compartiment 1	Vn1	litre	96	96	88	77,5
Volume net pour le compartiment 2	Vn2	litre	96	96	88	77,5
Volume net pour le compartiment 3	Vn3	litre	96	96	88	77,5
Volume net pour le compartiment 4	Vn4	litre	-	-	-	-
Volume net total	VnT	litre	288	288	264	232
Classe climatique	CC		5	5	5	5
Fluide frigorigène			R290	R290	R290	R290
Charge		kg	0.055	0.065	0.065	0.065
PRG			3	3	3	3
Equivalent CO2		CO ₂	0,165	0,195	0,195	0,195
A usage industriel ; cet appareil est conçu pour être utilisé à des températures ambiantes pouvant atteindre 40 °C			X	X	X	X
Contact	HOSHIZAKI EUROPE B.V.					
	Address: Burgemeester Stramanweg 101 1101 AA Amsterdam, The Netherlands Tel.: +31 (0)20 691 84 99 - http://hoshizaki.europe.com/					



Marque commerciale			HOSHIZAKI			
Nom du modèle			PREMIER F 4 A DL DL DR DR	PREMIER K/M 4 A DL DL DR DR	PREMIER K/M 4 A 2D 2D 2D 2D	PREMIER K/M 4 A 3D 3D 3D 3D
Usage prévu			Storage	Storage	Storage	Storage
Température de réfrigération				X	X	X
Température de congélation			X			
Armoire polyvalente						
Armoire verticale						
Comptoir réfrigéré			X	X	X	X
Paramètre	Symbol	Unit				
Classe d'efficacité énergétique	EEC	-	C	A	A	A
Indice d'efficacité énergétique	EEl	-	44,77	17,37	21,87	22,79
Consommation énergétique sur 24 h	E24h	kWh	5,67	1,319	1,612	1,612
Consommation énergétique annuelle	AEC	kWh	2070	481	588	588
Volume net pour le compartiment 1	Vn1	litre	96	96	88	77,5
Volume net pour le compartiment 2	Vn2	litre	96	96	88	77,5
Volume net pour le compartiment 3	Vn3	litre	96	96	88	77,5
Volume net pour le compartiment 4	Vn4	litre	96	96	88	77,5
Volume net total	VnT	litre	384	384	352	310
Classe climatique	CC		4	5	4	4
Fluide frigorigène			R290	R290	R290	R290
Charge		kg	0.055	0.065	0.065	0.065
PRG			3	3	3	3
Equivalent CO2		CO ₂	0,165	0,195	0,195	0,195
A usage industriel ; cet appareil est conçu pour être utilisé à des températures ambiantes pouvant atteindre 40 °C				X		
Contact details:	HOSHIZAKI EUROPE B.V.					
	Address: Burgemeester Stramanweg 101 1101 AA Amsterdam, The Netherlands Tel.: +31 (0)20 691 84 99 - http://hoshizaki.europe.com/					

HOSHIZAKI

PREMIER UNDERCOUNTER



II. CONSIGNES D'UTILISATION

ELECTRICITE

Avant de raccorder le produit à une source d'alimentation électrique, vérifier que les spécifications indiquées sur la plaque signalétique du produit correspondent à l'alimentation secteur locale.

La plaque signalétique du produit spécifiant l'alimentation électrique à utiliser se trouve à l'intérieur de l'armoire, en haut à gauche.

L'installation du produit ne doit être réalisée que par du personnel d'entretien qualifié et formé, conformément aux spécifications du présent manuel.

La sécurité électrique de cette armoire n'est valable que si cette dernière est reliée à la terre conformément aux lois et réglementations locales en vigueur.

La mise à la terre du produit est toujours requise.

Le fabricant n'est en aucun cas responsable des dommages résultant d'une mise à la terre incorrecte.

Il convient de respecter toutes les exigences en matière d'électricité, stipulées par les réglementations électriques locales. La fiche électrique du produit et la prise secteur doivent présenter un relevé de prise de terre correct. Si nécessaire, faire appel à un électricien qualifié.

CONTROLES GENERAUX PREALABLES

S'assurer que l'armoire repose à la verticale sur un sol plat. Si nécessaire, les pieds réglables de l'armoire peuvent être utilisés pour y parvenir. Tous les pieds doivent être en contact avec le sol. Cette condition est indispensable pour un fonctionnement correct de la porte de l'armoire.

Ne pas positionner l'armoire à côté d'appareils générant de la chaleur tels que des fours, grills et friteuses. Ne pas exposer le produit au rayonnement direct du soleil. La chaleur susceptible de rayonner par les parois ou les sols doit être isolée au moyen de matériaux d'isolation appropriés. L'armoire doit être positionnée le plus loin possible de toute source de chaleur.

Si l'armoire est déplacée, attendre trois heures avant de la remettre en marche. La protection en plastique ou le ruban adhésif présent(e) sur les surfaces externes doit être retiré(e).

Vérifier que l'armoire est positionnée de manière à laisser passer suffisamment d'air frais vers/depuis le circuit de refroidissement et autour des surfaces de l'armoire. Laisser au moins 500 mm d'espace libre au-dessus de l'armoire.

Si deux réfrigérateurs ou congélateurs doivent être placés l'un à côté de l'autre, les espacer d'au moins 50 mm.

Ne pas obstruer les orifices de ventilation.

CONTROLES ELECTRIQUES PREALABLES

- Vérifier que la fréquence et la tension secteur de la prise sont conformes aux informations de la plaque signalétique.
- L'armoire est raccordée à une prise secteur au moyen d'un fusible de 13-16 A selon une connexion en série.
- Désactiver le fusible secteur raccordé au câble d'alimentation.
- Vérifier que la fiche de l'armoire peut être utilisée avec la prise secteur disponible et qu'elle s'insère bien dedans.

HOSHIZAKI

PREMIER UNDERCOUNTER



PREMIERES OPERATIONS ET CONTROLES

Une fois que les contrôles ci-dessus sont terminés, l'armoire peut être utilisée. L'interrupteur marche/arrêt met l'armoire sous/hors tension.

Une fois que l'armoire est sous tension, le compresseur commence à fonctionner. Le compresseur fonctionne jusqu'à ce que la température prédéfinie en usine soit atteinte. Les aliments ne doivent pas être placés dans l'armoire tant que la température pour accueillir les aliments à réfrigérer n'a pas été réglée.

La température peut être de nouveau réglée à l'aide du contrôleur tel que décrit dans le présent manuel.



IMPORTANT

- Laisser le produit refroidir jusqu'à la température définie avant d'y ranger des aliments.
- Ne jamais dépasser la capacité de charge maximale. La capacité maximale est un poids maximal réparti de 40 kg pour les tablettes des armoires verticales et de 20 kg pour les tablettes et les tiroirs des comptoirs réfrigérés.
- Se reporter à la section « Contrôles généraux préalables » du présent manuel pour en savoir plus sur l'espace requis pour une bonne ventilation autour du produit.
- Ne pas entreposer dans cet appareil des substances explosives telles qu'un gaz propulseur inflammable en aérosol.
- **Dans le cas d'un tiroir 1/3, le couvercle du conteneur avec équipement d'étanchéité ne peut pas être utilisé.**

AVERTISSEMENT :

- Ne jamais obstruer les orifices de ventilation de l'appareil.
- Pour accélérer le processus de décongélation, ne pas utiliser d'équipements mécaniques ni des méthodes autres que celles recommandées par le fabricant.
- Veiller à ne pas endommager le circuit réfrigérant.
- Ne pas utiliser d'appareils électriques à l'intérieur de l'armoire.
- Ne pas endommager le cordon d'alimentation, le câblage ou tout composant clé.

CONDITIONS DE STOCKAGE ET PERFORMANCES

Les conditions de stockage correctes sont non seulement primordiales pour l'hygiène et la sécurité alimentaire, mais elles améliorent également la qualité du service et réduisent la consommation énergétique. Les meilleures performances peuvent être atteintes si les astuces et instructions suivantes sont observées : conserver tous les aliments sur les tablettes uniquement et ne jamais poser d'aliments sur le plancher de l'armoire. Les aliments doivent être posés dans l'armoire ou le comptoir de manière à laisser circuler l'air frais tout autour, en laissant de l'espace entre eux et par rapport aux parois du produit. Si nécessaire, la distance entre les tablettes peut être réglée.

HOSHIZAKI

PREMIER UNDERCOUNTER



III. PANNEAU DE CONTROLE



➤ FONCTIONS DU PANNEAU AVANT

Pour verrouiller les touches du panneau avant, maintenir enfoncées les touches AUX (3) et Marche/Veille (1) pendant 2 secondes : le texte « Loc » s'affiche à l'écran lorsque les touches sont verrouillées, le texte « UnL » s'affiche si elles ne sont pas verrouillées.

1) Lorsque la touche **Marche/Veille** est maintenue enfoncée pendant quatre secondes, l'appareil s'ouvre ou se ferme. (Marche/Arrêt)

2) **DEGIVRAGE MANUEL** : si la touche est enfoncée pendant quatre secondes, le dégivrage manuel commence. En cas de refroidissement excessif et si la température de l'évaporateur n'est pas adaptée, le dégivrage manuel ne commence pas.

3) Touche **BAS** : pour faire défiler le menu vers le bas ou réduire la valeur ; si la touche est maintenue enfoncée pendant quatre secondes, le refroidissement extrême s'active. Lorsque la fonction de refroidissement extrême est active, la température définie peut être réduite ; la durée et la température sont déterminées à l'aide des paramètres. Lorsque la fonction de refroidissement extrême est activée, l'appareil ne dégivre jamais.

4) Touche **HAUT** : pour faire défiler le menu vers le haut ou augmenter la valeur ; si la touche est maintenue enfoncée pendant quatre secondes, la fonction de pourcentage faible ou élevé d'humidité relative est activée. (Sur certains modèles) « rhL » s'affiche à l'écran (la fonction de faible pourcentage d'humidité relative est utilisée) ou « rhH » s'affiche (la fonction de pourcentage élevé d'humidité relative est utilisée). Ces fonctions s'affichent à l'écran pendant 10 secondes. Si le contrôle de l'humidité n'est pas disponible, « ---- » s'affiche à l'écran pendant une seconde.

5) Touche **DEFINIR (SET)** : touche de saisie et de modification pour les valeurs réglables.

➤ FONCTIONNEMENT

Des exemples d'utilisation sont décrits ci-dessous :

Etat « Marche » : l'appareil est sous tension et fonctionne.

Etat « En veille » : l'appareil est hors tension, mais il est toujours alimenté.

Etat « Arrêt » : pour mettre l'appareil hors tension, retirer la fiche de la prise ou désactiver le fusible de l'alimentation principale.

HOSHIZAKI

PREMIER UNDERCOUNTER



IV. INSTRUCTIONS D'ENTRETIEN

Cet appareil doit être nettoyé régulièrement. L'intervalle de nettoyage dépend de l'utilisation et du degré de salissure (au moins une fois par an).



Avant toute opération de nettoyage ou d'entretien, débrancher l'appareil.



Ne pas toucher ou mouiller les pièces du compartiment de l'appareil. Cela pourrait entraîner une panne.



Afin d'éviter tout dommage possible, ne pas nettoyer les pièces en plastique avec de l'eau à plus de 40 °C ou dans un lave-vaisselle.

Intérieur et extérieur de l'armoire et des tablettes



Pour une utilisation respectant les normes d'hygiène, nettoyer l'intérieur et l'extérieur au moins une fois par semaine.



Nettoyer l'intérieur et l'extérieur de l'armoire à l'aide d'un chiffon doux humidifié avec de l'eau froide ou chaude, contenant une quantité suffisante de nettoyant neutre, et essoré. Ne pas utiliser un jet d'eau pour nettoyer le compartiment de l'appareil.



Les agents chimiques et tous les autres nettoyants non neutres peuvent endommager les surfaces intérieures et extérieures.



Tout reste de détergent endommagerait les surfaces métalliques ou plastiques. Essuyer à l'aide d'un chiffon doux imbibé d'eau tiède.



Ne pas utiliser les éléments suivants, ils risqueraient d'endommager les surfaces peintes ou en plastique :

- Poudre abrasive, alcool, diluant, essence, détergent acide ou alcalin, eau chaude, pétrole, poudre de savon, tampon à récurer ou brosse métallique, etc. Tout particulièrement, les détergents destinés au nettoyage des graisses sur les ventilateurs ou fours micro-ondes.

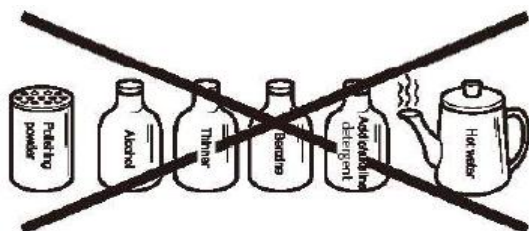

Remarque : **certaines solutions autres que celles mentionnées ci-dessus sont également susceptibles d'endommager les surfaces peintes ou en plastique. Arrêter immédiatement l'utilisation de telles solutions en cas de problème !**



Le joint de porte et sa surface de contact se salissent facilement. Nettoyez chacune de ces surfaces soigneusement. Les traces d'aliments non éliminées accélèrent le vieillissement de l'appareil.

PREMIER UNDERCOUNTER



Utilisez un chiffon pour essuyer toute trace d'eau à l'intérieur de l'appareil.

Condenseur



Utiliser un aspirateur ou une brosse douce pour éliminer la poussière et les taches du condenseur.



Avertissement : si le condenseur est nettoyé à l'aide d'une brosse dure, telle qu'une brosse pour laver la vaisselle, le revêtement du condenseur risque de se décoller.

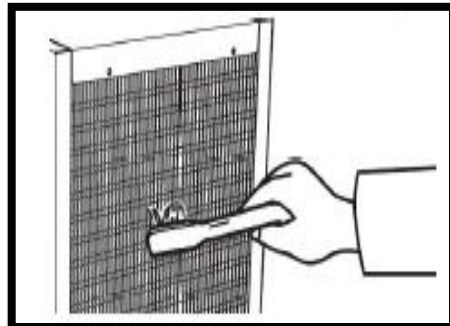

Filtre à air



Pour éviter toute déformation, ne pas nettoyer le filtre à air avec de l'eau chaude à une température supérieure à 40 °C.



Des filtres à air en plastique permettent de filtrer les impuretés et la poussière de l'air et empêchent l'obturation du condenseur. Si les filtres sont encrassés, les performances du réfrigérateur/congélateur seront affectées.



Vérifier les filtres deux fois par mois minimum. En cas de colmatage ou lorsque le contrôleur de la température indique « CH », laver les filtres en utilisant une solution d'eau chaude et de produit nettoyant neutre. Ne pas utiliser l'unité sans filtres à air, le condenseur se boucherait, ce qui provoquerait une panne.

- 1) Ouvrir le panneau avant et retirer le filtre à air. Pour éviter tout risque de blessure, ne pas toucher directement les ailettes du condenseur.
- 2) Laver soigneusement le filtre à air avec de l'eau froide ou chaude contenant une quantité suffisante de produit nettoyant neutre. Rincer et sécher soigneusement le filtre à air.
- 3) Pour remettre en place le filtre à air, placer les deux pattes de l'échangeur thermique ou les ailettes dans le condenseur et fixer fermement le filtre à air sur le condenseur.

PREMIER UNDERCOUNTER

V. INFORMATIONS TECHNIQUES DIMENSIONS DES APPAREILS

PREMIER K-M-F 2 A DL DR L

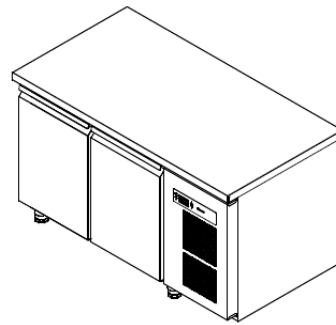
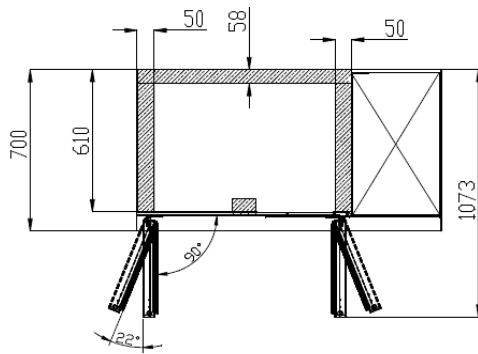
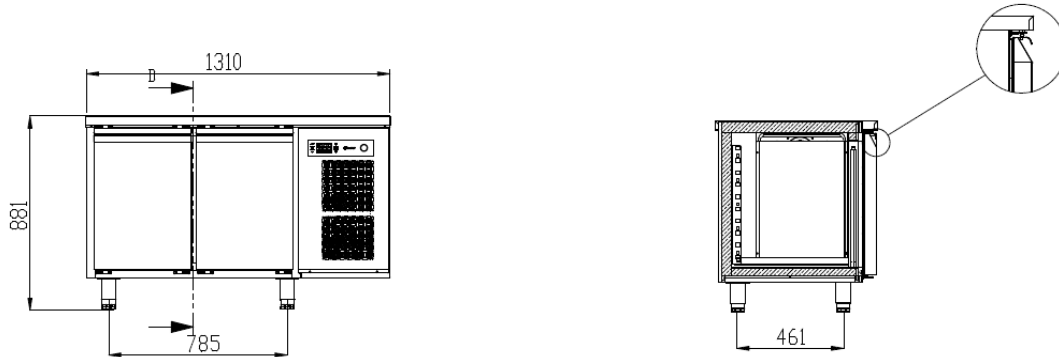

PREMIER K-M-F 2 A DL DR C

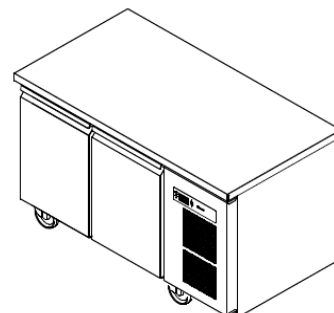
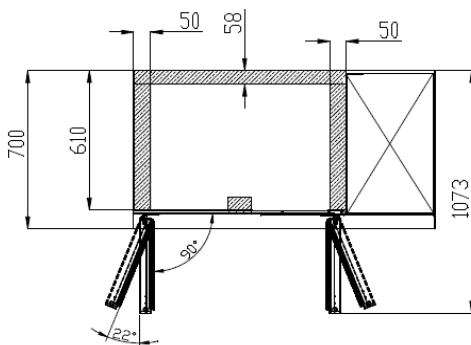
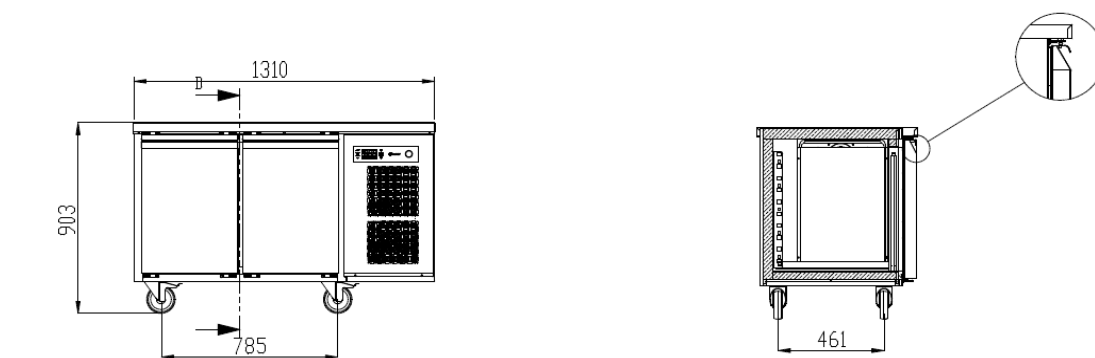

HOSHIZAKI

PREMIER UNDERCOUNTER



PREMIER K-M 2 A 2D 2D L

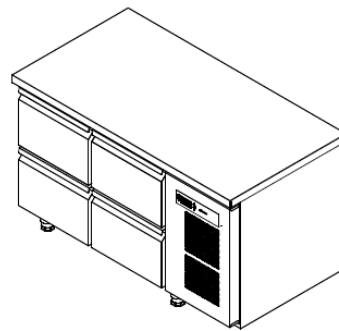
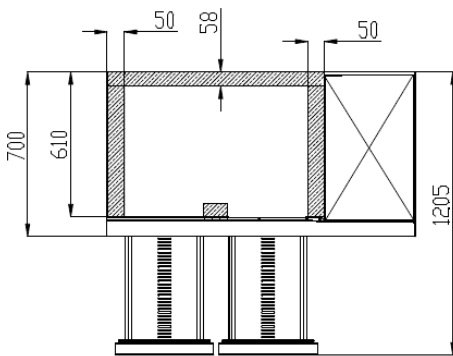
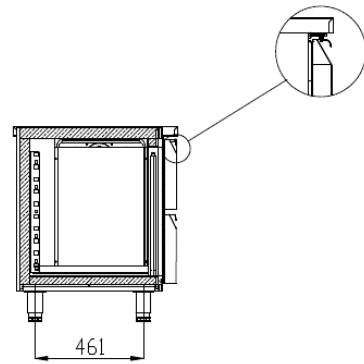
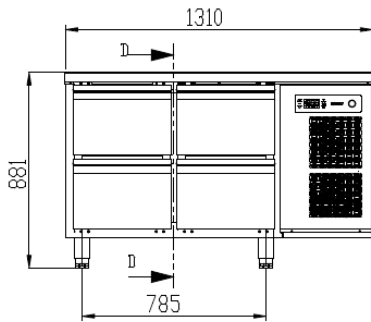

PREMIER K-M 2 A 2D 2D C

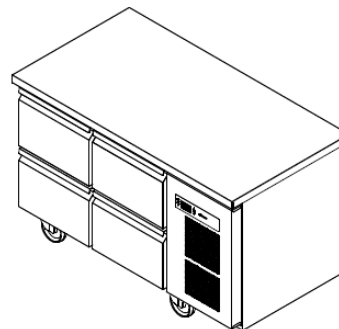
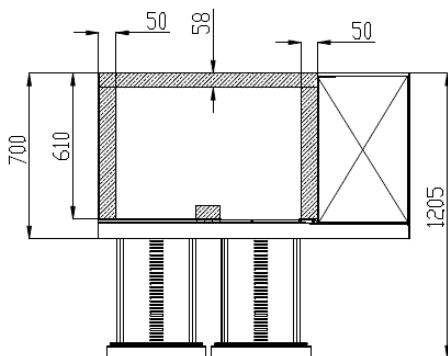
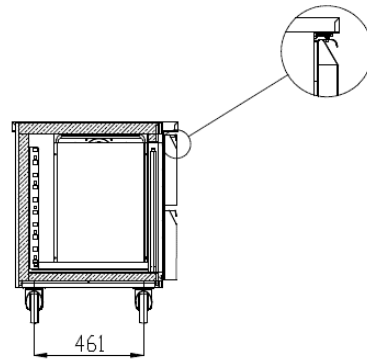
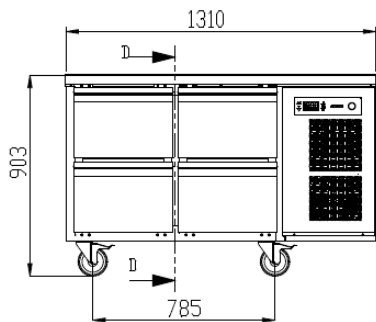

HOSHIZAKI

PREMIER UNDERCOUNTER



PREMIER K-M 2 A 3D 3D L

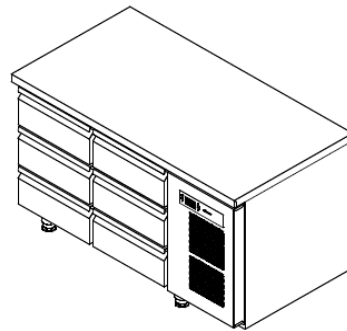
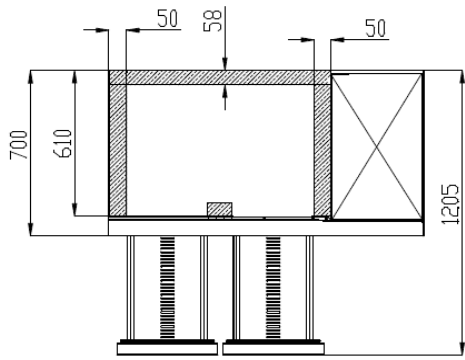
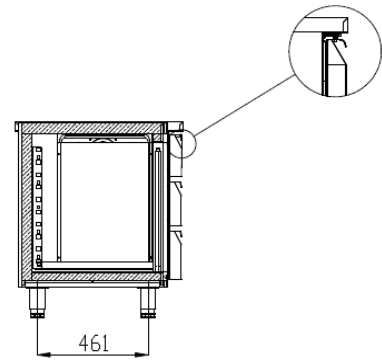
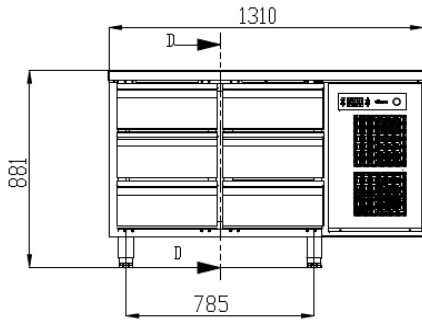

PREMIER K-M 2 A 3D 3D C

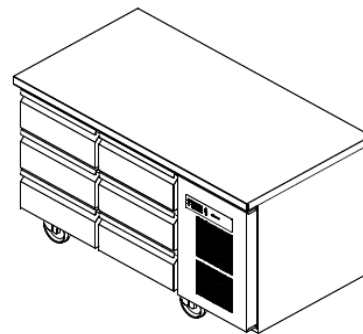
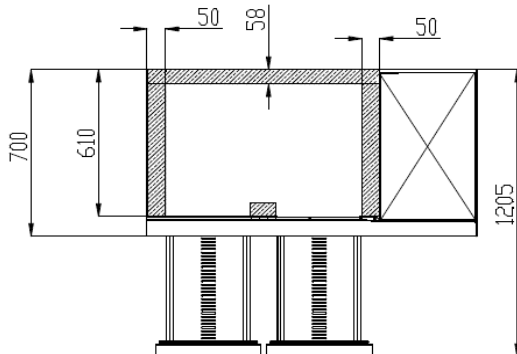
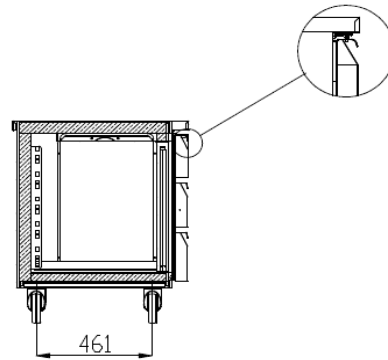
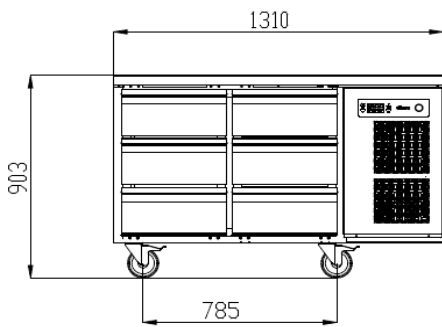

HOSHIZAKI

PREMIER UNDERCOUNTER



PREMIER K-M-F 3 A DL DR DR L

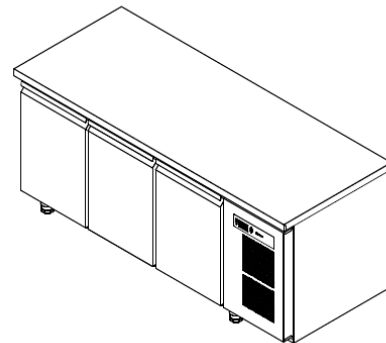
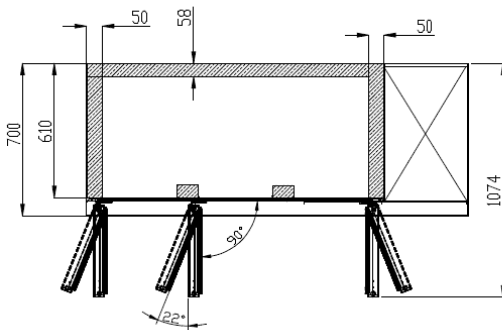
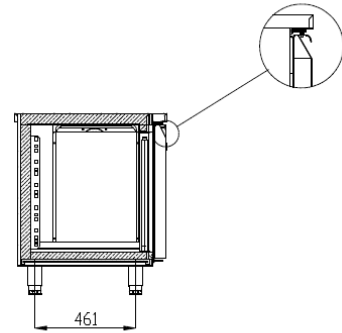
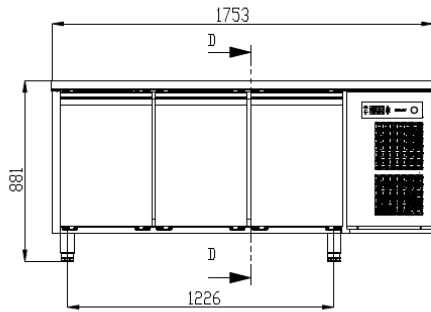

PREMIER K-M-F 3 A DL DR DR C

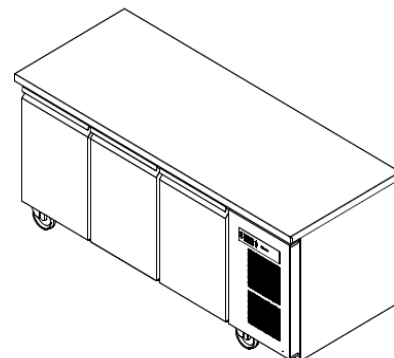
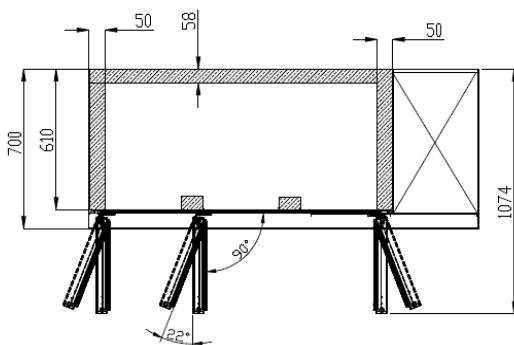
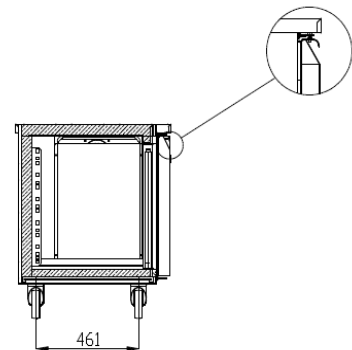
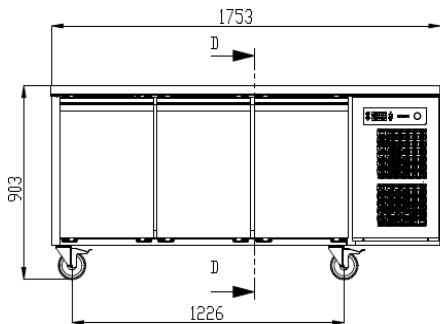

HOSHIZAKI

PREMIER UNDERCOUNTER



PREMIER K-M 3 A 2D 2D 2D L

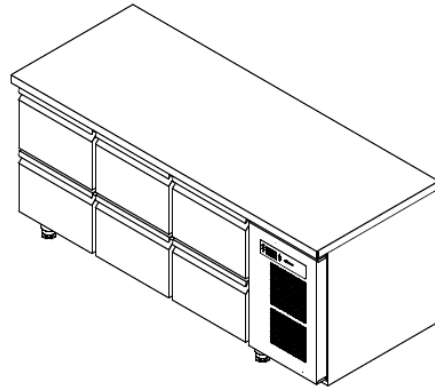
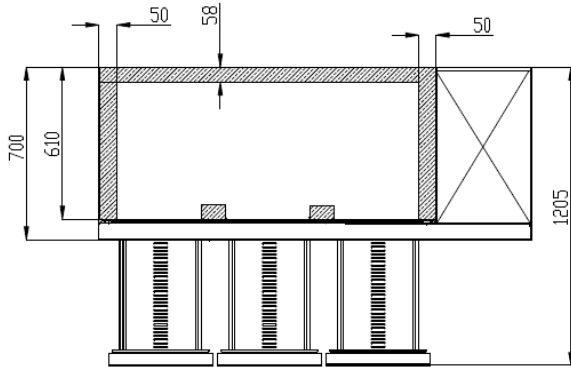
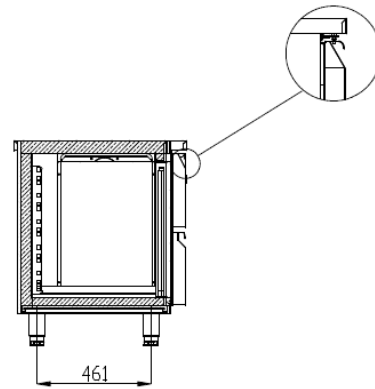
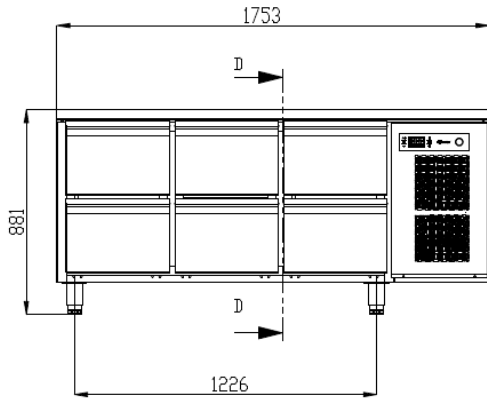

PREMIER K-M 3 A 2D 2D 2D C

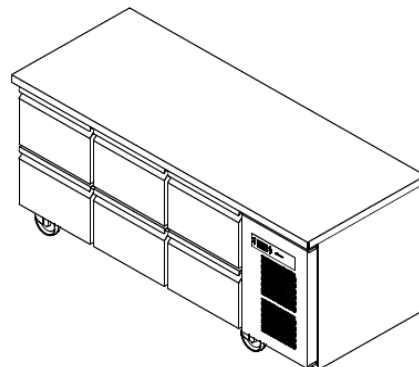
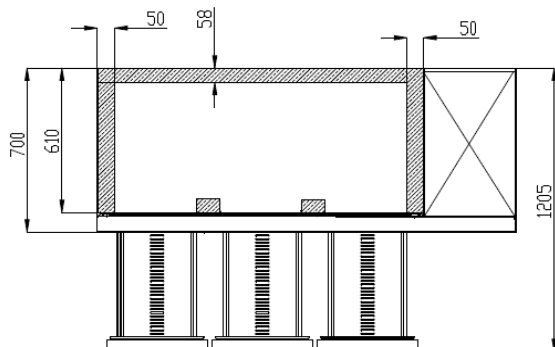
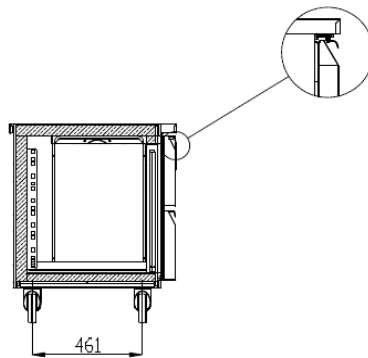
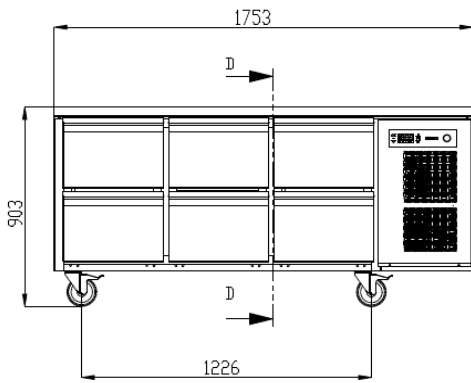

HOSHIZAKI

PREMIER UNDERCOUNTER



PREMIER K-M 3 A 3D 3D 3D 3 L

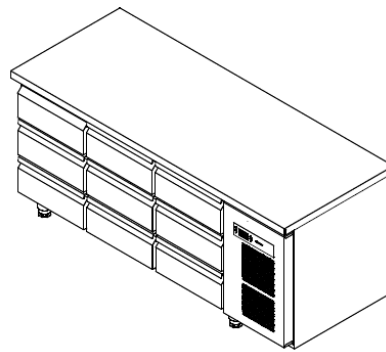
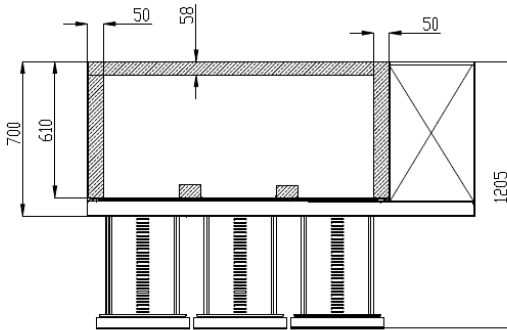
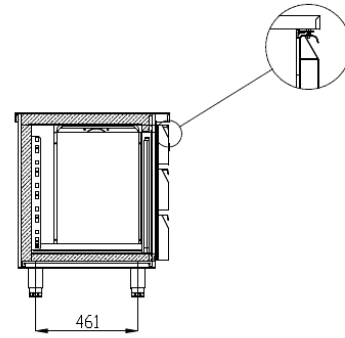
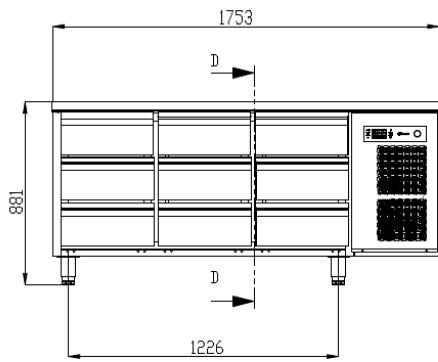

PREMIER K-M 3 A 3D 3D 3D 3 C

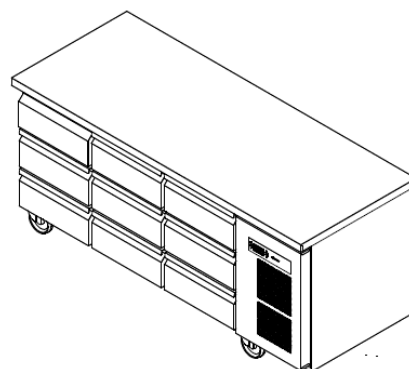
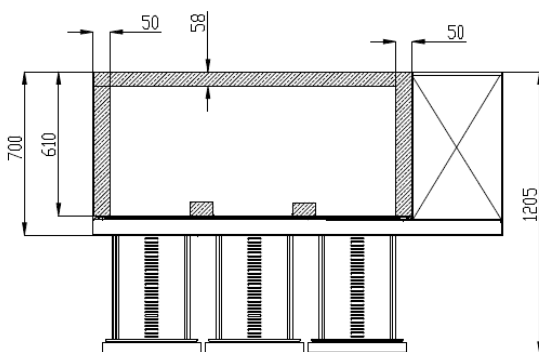
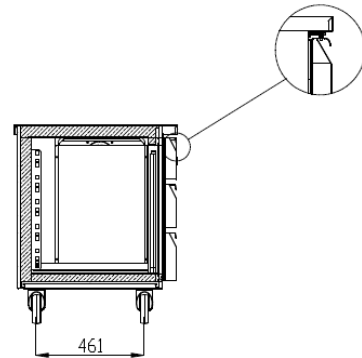
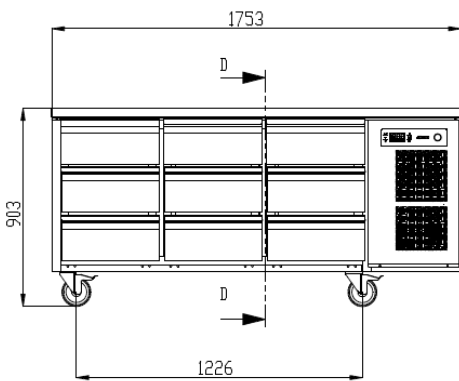

HOSHIZAKI

PREMIER UNDERCOUNTER



PREMIER K-M-F 4 A DL DL DR DR L

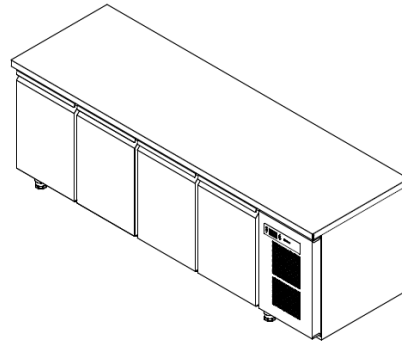
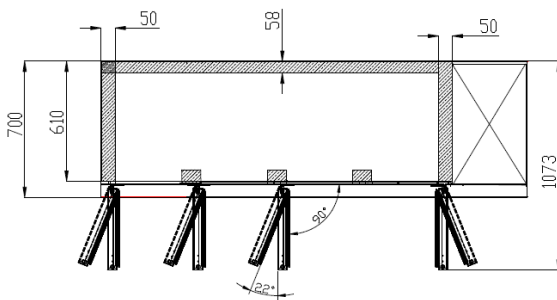
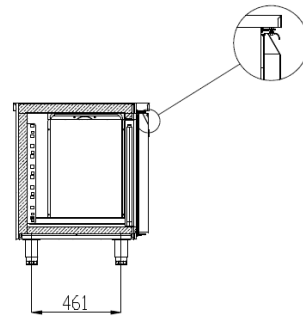
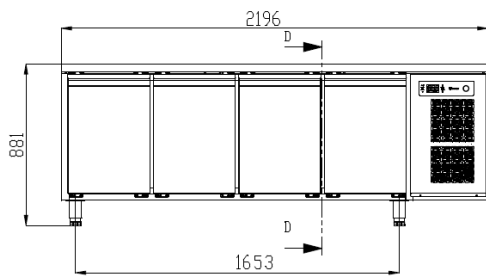

PREMIER K-M-F 4 A DL DL DR DR C

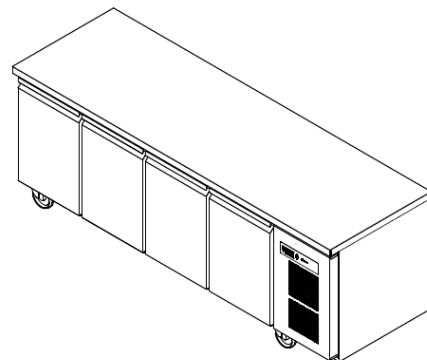
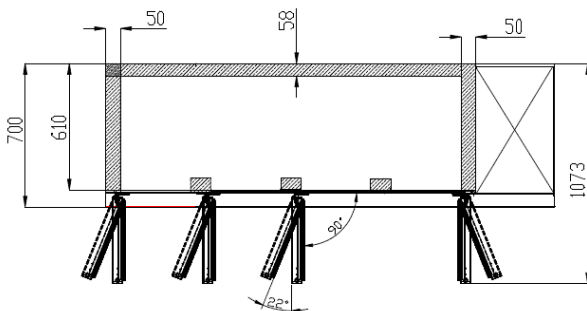
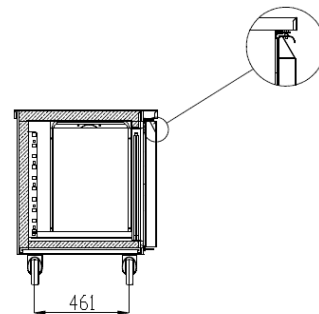
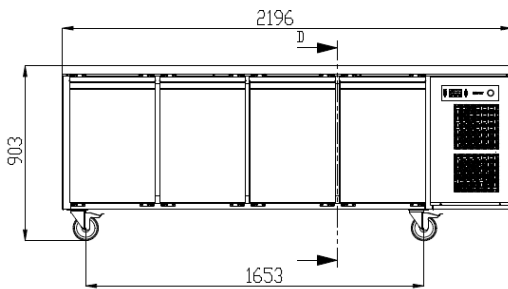

HOSHIZAKI

PREMIER UNDERCOUNTER



PREMIER K-M 4 A 2D 2D 2D 2D L

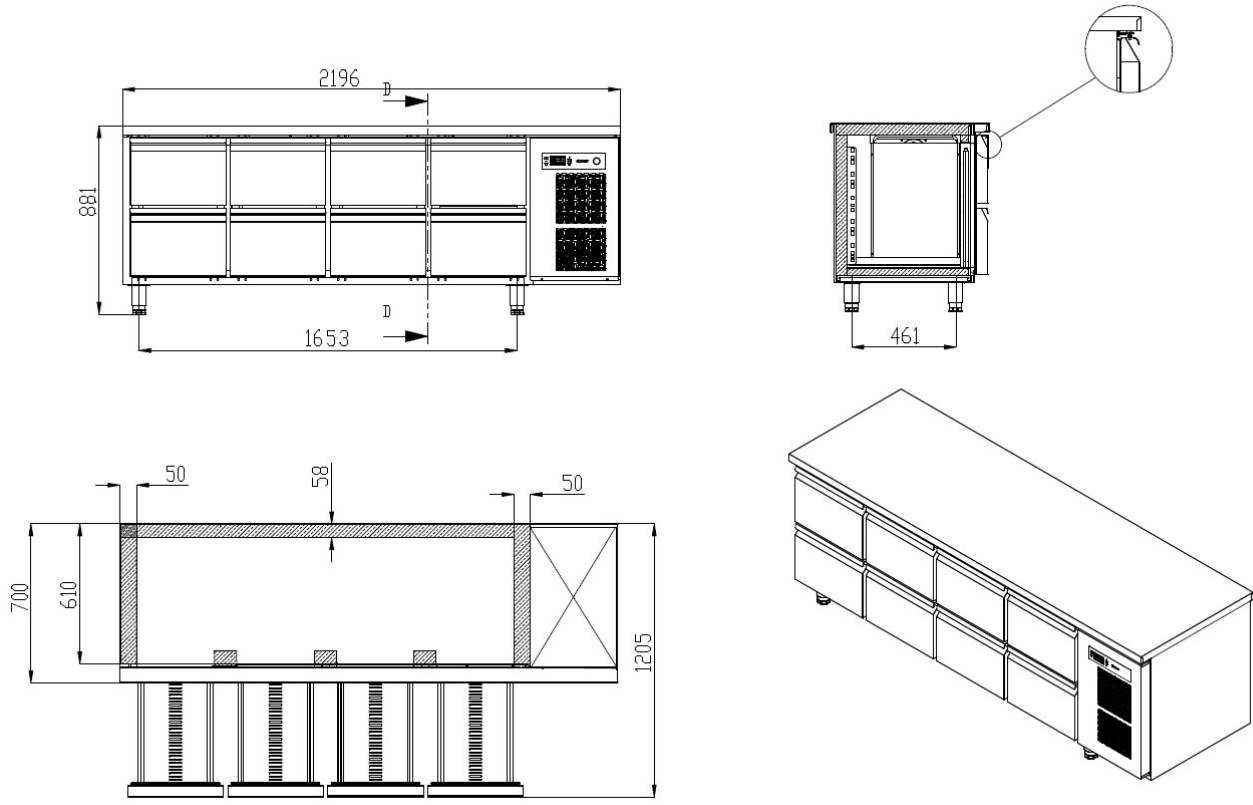

PREMIER K-M 4 A 2D 2D 2D 2D C

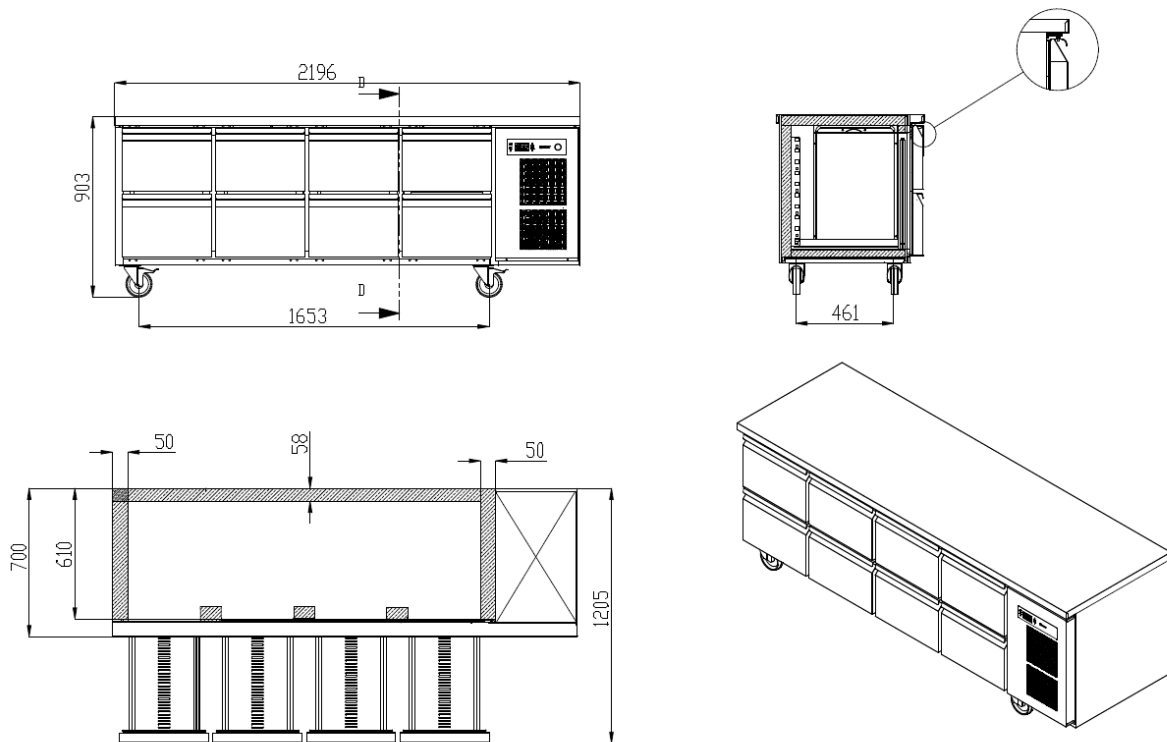

HOSHIZAKI

PREMIER UNDERCOUNTER



PREMIER K-M 4 A 3D 3D 3D 3D L

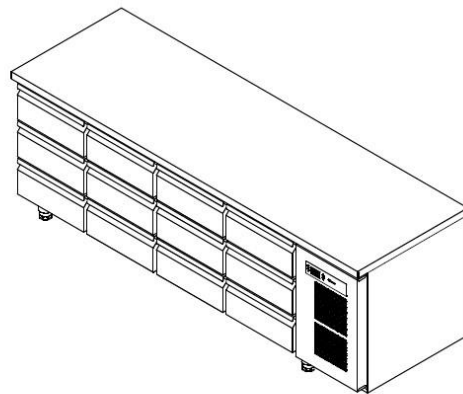
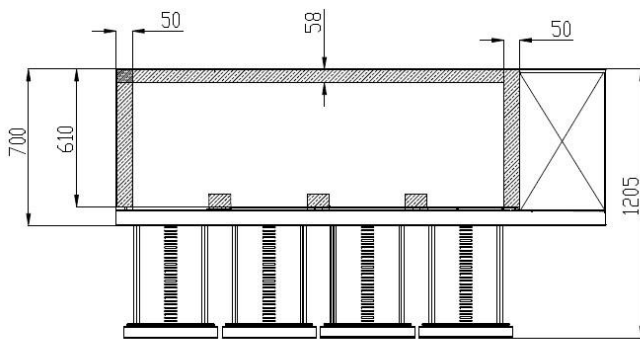
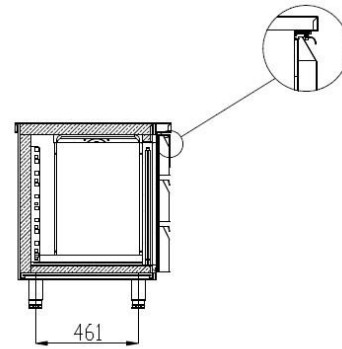
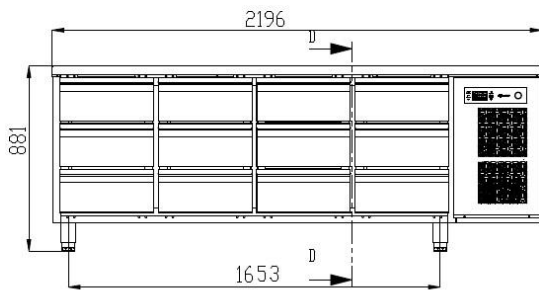

PREMIER K-M 4 A 3D 3D 3D 3D C

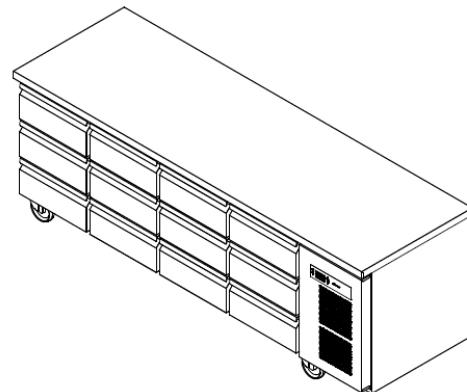
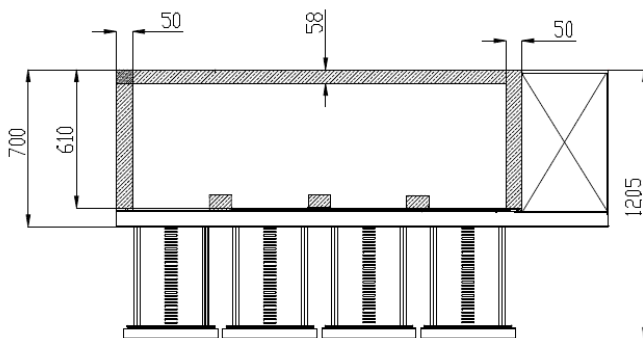
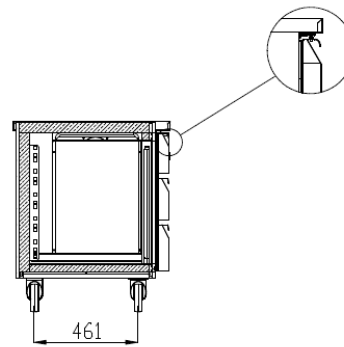
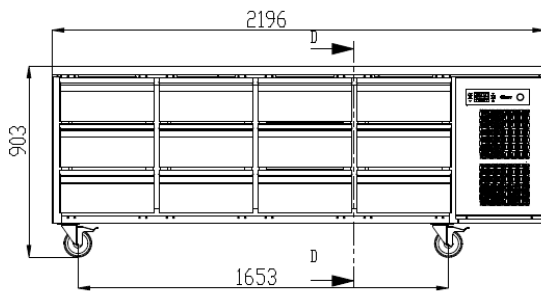

HOSHIZAKI

PREMIER UNDERCOUNTER



VI. SCHEMA DE REFROIDISSEMENT – SCHEMA DE CABLAGE

SCHEMA DE REFROIDISSEMENT

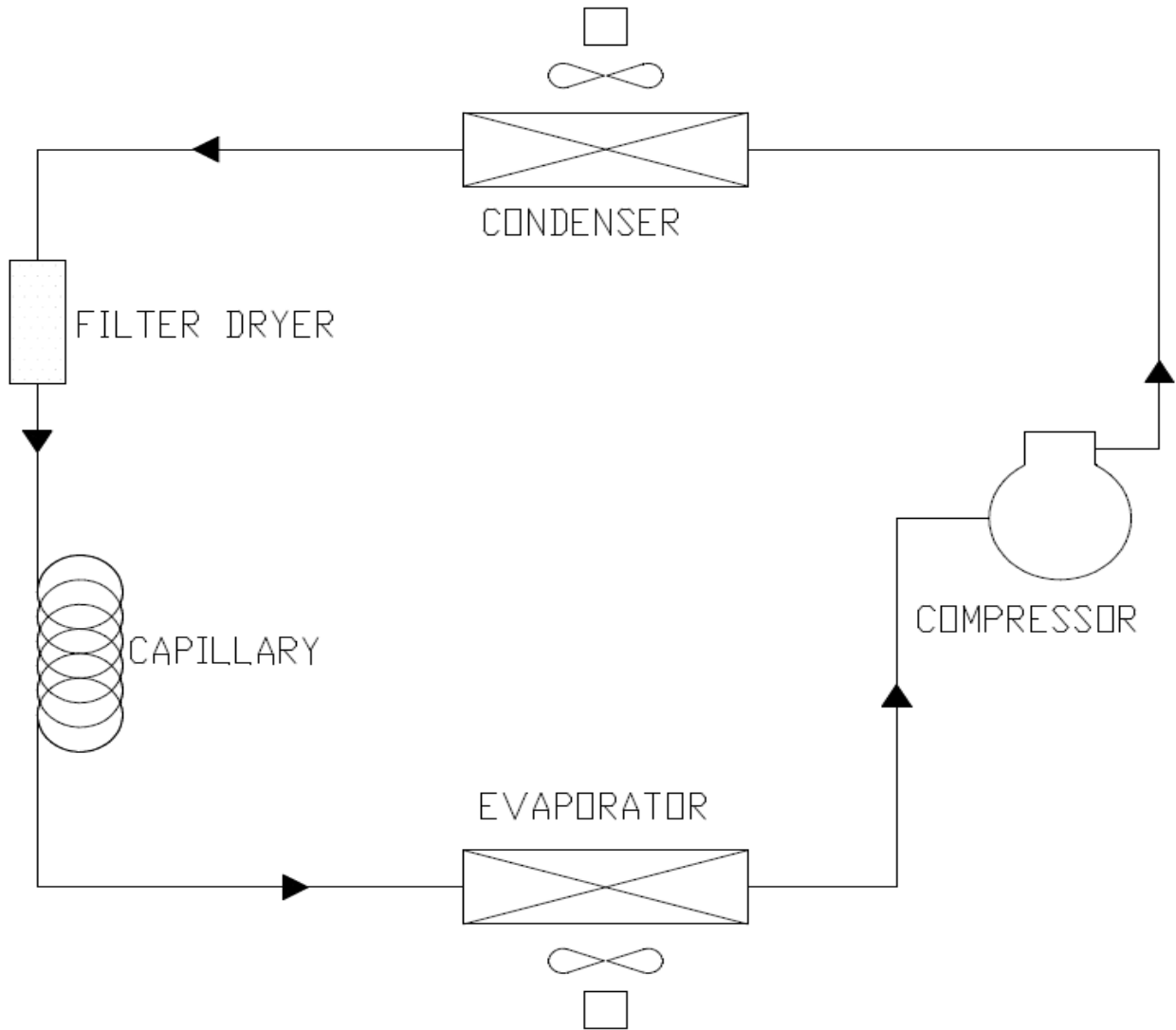

HOSHIZAKI

PREMIER UNDERCOUNTER



SCHEMA DE CABLAGE ELECTRIQUE

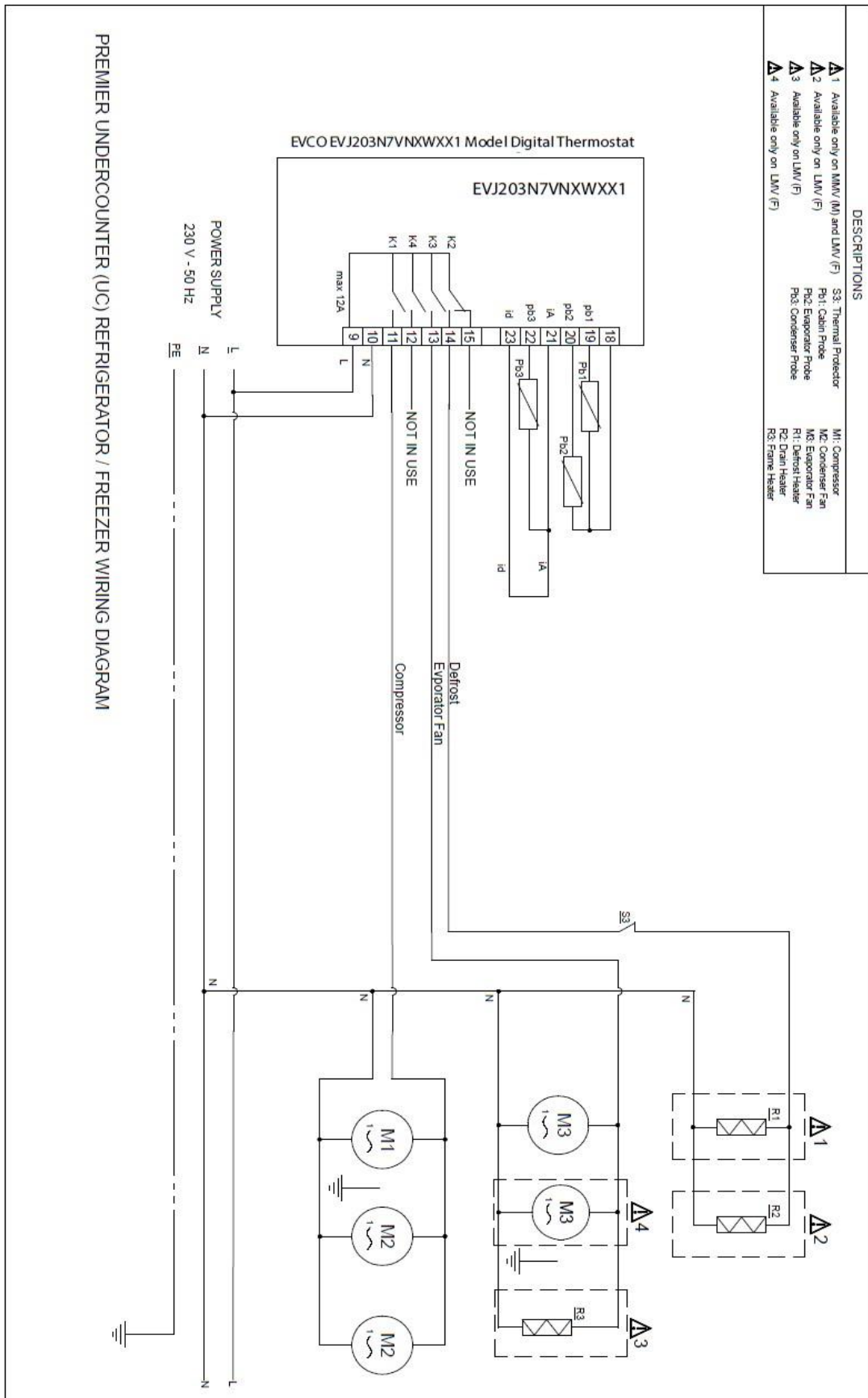

PREMIER UNDERCOUNTER

VII. TABLEAU DE DIAGNOSTIC

Le tableau ci-dessous répertorie plusieurs problèmes possibles. Si un code d'alarme s'affiche, cela indique qu'un dysfonctionnement s'est produit. Corriger toutes les causes possibles avant de réinitialiser l'armoire. Les causes possibles et les solutions sont répertoriées ci-dessous.

Si un code d'erreur persiste une fois les contrôles ci-dessous effectués, contacter un technicien agréé. Les caractéristiques du message d'erreur doivent être déterminées. Les informations relatives au produit, y compris le numéro de série, sont indiquées sur la plaque signalétique du produit.

PROBLEME	CAUSE POSSIBLE	SOLUTION	
L'armoire ne fonctionne pas	L'armoire n'est pas alimentée électriquement	Vérifier que la fiche d'alimentation et le câble sont en bon état	
Le compresseur cesse parfois de fonctionner	La température ambiante est trop élevée	La ventilation doit être améliorée	
	Le condenseur ou le filtre du condenseur est obstrué	Vérifier et nettoyer régulièrement le filtre du condenseur	
	Les joints de porte ne sont pas suffisamment étanches	Appeler un technicien agréé pour remplacer les joints	
	L'évaporateur est gelé		Ne pas placer d'aliments chauds dans cette armoire
			Ne pas placer dans cette armoire d'aliments à teneur élevée en eau, sauf s'ils sont rangés dans des récipients hermétiques
		Lancer un cycle de dégivrage manuel	
Débordement d'eau du plateau de récupération d'eau du condenseur	Rangement fréquent d'aliments chauds dans l'armoire	Ne pas placer d'aliments chauds dans cette armoire	
		Ranger les aliments à teneur élevée en eau dans l'armoire uniquement dans des récipients hermétiques	
	Ouverture fréquente de la porte ou des tiroirs	Vérifier si les spécifications de l'armoire confirment qu'elle est adaptée à l'usage actuel	
Température à l'intérieur de l'appareil élevée	Le condenseur est obstrué par de la saleté et de la poussière	Vérifier et nettoyer régulièrement le filtre du condenseur	
	Le flux d'air dans l'armoire est bloqué	Retirer les aliments qui bloquent le flux d'air	
	L'air ambiant entre dans l'armoire	Vérifier que la porte est fermée	
		Vérifier que les joints de la porte et des tiroirs sont en bon état	
	L'évaporateur est gelé	Contacteur un technicien agréé	
		Lancer un cycle de dégivrage manuel	

PREMIER UNDERCOUNTER

VIII. DEPOSE ET REMPLACEMENT

MISE AU REBUT DE L'ARMOIRE

- Le nom du gaz de refroidissement présent dans l'armoire est indiqué sur la plaque signalétique.
- L'armoire est fabriquée à partir de matériaux recyclables conformément aux réglementations de l'UE. Par conséquent, à la fin de sa durée de vie utile, l'armoire doit être confiée à un centre de recyclage adapté.
- Ne pas mettre l'armoire au rebut avec les déchets métalliques ou ménagers.
- Ne pas compresser le circuit de réfrigération de l'appareil de refroidissement.



IMPORTANT

Respecter les lois et réglementations locales pour la mise au rebut de l'armoire.

HOSHIZAKI

PREMIER UNDERCOUNTER



Tous droits réservés. Hoshizaki se réserve le droit de modifier les caractéristiques, ainsi que les informations présentes dans ce manuel.

Contact

Siège social

Hoshizaki Europe B.V – All other countries in Europe and Africa

TEL: +31 (0)20 6918499

sales@hoshizaki.nl -- <http://hoshizaki-europe.com/>

Filiales

Hoshizaki UK - UK, Ireland

TEL: +44 (0)845 456 05 85

uksales@hoshizaki.co.uk

Hoshizaki Deutschland - Germany, Switzerland, Austria

TEL: +49 (0)5121 697370

vertrieb@hoshizaki.de

Hoshizaki Benelux - Netherlands, Belgium, Luxembourg

TEL: +31 (0)85 0188370

info@hoshizaki.nl

Hoshizaki France - France

TEL: +33 (0)1 48 63 93 80

info@hoshizaki.fr

Hoshizaki Iberia - Spain, Portugal

TEL: +34 (0)93 478 09 52

info@hoshizaki.es

Hoshizaki Denmark - Denmark

TEL: +45 89 88 53 50

salg@hoshizaki.dk

Hoshizaki Norway - Norge

TEL: +47 22 88 17 50

salg@hoshizaki.no

Hoshizaki Sweden - Sverige

TEL: +46 108 84 87 47

OrderSE@hoshizaki.dk

Hoshizaki Italia – Italia

TEL: +39 348 3022156

commerciale@hoshizaki.it

HOSHIZAKI

PREMIER UNDERCOUNTER



HOSHIZAKI

PREMIER UNDERCOUNTER



KÜHL- UND GEFRIERSCHRÄNKE BEDIENUNGS-, WARTUNGS- UND MONTAGEANLEITUNG



I. ALLGEMEINE INFORMATIONEN	54
II. BEDIENUNGSANLEITUNG	59
III. BEDIENFELD	61
IV. WARTUNGSANLEITUNG	62
V. TECHNISCHE INFORMATIONEN	64
VI. KÜHLUNGSDIAGRAMM – SCHALTBILD	73
VII. FEHLERSUCHE	75
VIII. AUSBAU UND AUSTAUSCH	76

Kontakt:
HOSHIZAKI EUROPE B.V.
 Adresse: Burgemeester Stramanweg 101 1101 AA Amsterdam, Niederlande
 Tel.: +31 (0)20 691 8499 <http://hoshizaki-europe.com/>



PREMIER UNDERCOUNTER

I. ALLGEMEINE INFORMATIONEN

PRODUKTBESCHREIBUNGSETIKETT

1 - Produktnummer
2 - Produktbeschreibung
3 - Modell
4 - Kältemittel (GWP)
5 - CO ₂ -Äquivalent
6 - IP-Schutzklasse
7 - Klimaklasse
8 - Produktionsdatum
9 - Gesamtleistung / Strom / Lampenleistung
10 - Spannung – Frequenz
11 - Heizelement
12 - Systemdruck
13 - Treibmittel
14 - Seriennummer

PRODUCT NUMBER	1
----------------	---



PRODUCT DESCRIPTION	2
MODEL	3
REFRIGERANT	4
CO ₂ EQUIVALENT	5
IP PROTECTION	6
CLIMATE CLASS	7
PRODUCTION DATE	8
TOTAL POWER / CURRENT / LAMP POWER	9
VOLTAGE - FREQUENCY	10
HEATING ELEMENT	11
SYSTEM PRESSURE	12
BLOWING AGENT	13

S/N: 14



HOSHIZAKI EUROPE B.V. Burgemeester Stramanweg 101 1101 AA
Amsterdam, The Netherlands



VERWENDUNGSZWECK

- Das Produkt eignet sich ausschließlich für den Gebrauch in Innenräumen und zur Aufbewahrung von Lebensmitteln und Getränken. Die Aufbewahrungsfächer sind dazu ausgelegt, Produkttemperatur von bereits gekühlten/gefrorenen Produkten beizubehalten.
- Der Hersteller haftet nicht für Schäden aufgrund einer Verwendung, die von den in diesem Handbuch beschriebenen Leitlinien abweicht.
- Bei der Aufbewahrung von Lebensmitteln in diesem Schrank dürfen die Lebensmittel nicht in Kontakt mit dem Schrankgehäuse gelangen.
- Alle Lebensmittel müssen vollständig bedeckt sein. Um eine Verunreinigung und Korrosion an internen Bauteilen zu verhindern, sollten alle Produkte verpackt sein oder in verschlossenen Behältern aufbewahrt werden.
- Keine heißen Lebensmittel oder Flüssigkeiten in diesem Schrank aufbewahren.
- In Kartons und Glasflaschen abgefüllte Getränke sollten nicht bei unter 0 °C (Gefrierpunkt) aufbewahrt werden. Dosen und Glasflaschen können bei Ausdehnung der darin befindlichen Flüssigkeit platzen. Deckelbehälter sollten nicht randvoll gefüllt werden; stattdessen sollte ein wenig Platz für Ausdehnung belassen werden.
- Der Schrank verfügt über eine automatische Abtaufunktion. Das Abtauen kann auch manuell durchgeführt werden. Das manuelle Abtauen beinhaltet keine langfristige Abschaltung des Schanks und ist über die Steuerung möglich. Keinesfalls dürfen Gewalt oder Werkzeuge zum Enteisen des Schanks angewandt werden; Schäden aufgrund eines solchen Vorgehens lassen sich nur schwer beheben.
- Keine mechanischen oder alternativen Abtaumethoden anwenden.
- Das Gerät darf nicht von Personen (einschließlich Kinder) benutzt werden, deren körperliche, sensorische oder mentale Fähigkeiten eingeschränkt sind oder die über keine Erfahrung und kein Wissen verfügen, es sei denn, sie werden von einer für ihre Sicherheit verantwortlichen Person bei der Benutzung des Geräts beaufsichtigt oder angeleitet.

PREMIER UNDERCOUNTER

- Kindern darf nicht erlaubt werden, mit dem Gerät zu spielen.
- Reinigungs- und Wartungsarbeiten dürfen von Kindern nicht unbeaufsichtigt durchgeführt werden.
- Dieses Gerät darf nicht von Personen (einschließlich Kindern ab 8 Jahren) benutzt werden, deren körperliche, sensorische oder mentale Fähigkeiten eingeschränkt sind oder die über keine Erfahrung und kein Wissen verfügen, es sei denn, sie werden von einer für ihre Sicherheit verantwortlichen Person bei der sicheren Benutzung des Gerätes beaufsichtigt oder angeleitet.
- Elektrische oder mechanische Änderungen an diesem Schrank lassen die Garantie ungültig werden. Änderungen, die von nicht zugelassenen Technikern durchgeführt werden, oder nicht in dieser Anleitung beschriebene Änderungen lassen die Garantie ebenfalls ungültig werden. Der Hersteller haftet nicht für Schäden, die sich aus Änderungen dieser Art ergeben.

KLIMAKLASSE

Der Schrank ist für den Betrieb innerhalb bestimmter Umgebungstemperatur- und Luftfeuchtigkeitsgrenzen ausgelegt. Diese sind im Klimaklassensystem dargelegt. Die Werte dürfen niemals überschritten werden. Die Klimaklasse dieses Produkts können Sie auf dem Produktbeschreibungsetikett finden. Der Kühlschrank eignet sich nicht für die Verwendung bei einer Umgebungstemperatur unter 16 °C.

Klimaklasse	Umgebungstemperatur und Luftfeuchtigkeit
4	+30 °C bei % 55 RLF
5	+40 °C bei % 40 RLF

ERSTE ABNAHME UND KONTROLLEN

Der Schrank wurde zum Versand in schützendem Verpackungsmaterial verpackt. Prüfen Sie bei der Lieferung den Schrank auf etwaige Transportschäden und ob es sich um das von Ihnen bestellte Gerätemodell handelt.



WICHTIG

Alle unten aufgeführten Vorgänge müssen lokale Bestimmungen und Sicherheitsvorschriften vollständig erfüllen. Beachten Sie beim Betrieb des Produkts alle geltenden Sicherheitsvorschriften.

TRANSPORT

Beim Anheben des Produkts mit Maschinen muss zunächst die Hebefähigkeit der Maschine überprüft werden.



WICHTIG

Bei der Verwendung eines Gabelstaplers zum Transportieren des Produkts ist darauf zu achten, dass die Gabeln in die geeigneten Öffnungen in der Palette geführt werden.

Während des Transports ist auf die Stabilität des Produkts zu achten. Wenn der Schwerpunkt nicht in der Mitte des Produkts liegt, kann dieses Produkt leicht kippen. Beim Absenken des Produkts mit einem Gabelstapler langsam und vorsichtig vorgehen.

Sollte ein zur aufrechten Aufstellung vorgesehener Schrank liegend transportiert werden müssen, so muss der Schrank nach dem Transport mindestens 2 Stunden aufrecht stehen gelassen werden, bevor er in Betrieb genommen wird. Der liegende Transport von zur aufrechten Aufstellung vorgesehenen Schränken wird nicht empfohlen, und Schäden, die sich hieraus ergeben, sind nicht durch die Garantie abgedeckt.

PREMIER UNDERCOUNTER



ACHTUNG

Die Empfehlungen auf der Außenseite der Transportverpackung sind als Hilfestellung für den Benutzer gedacht. Daher sind folgende Empfehlungen zu beachten:

- Das Produkt vorsichtig tragen.
- Das Produkt trocken halten. Nichts auf der Oberseite des Schrankes aufbewahren!

ÖFFNEN DER VERPACKUNG

- Entfernen Sie die Pappe und andere Verpackungsmaterialien.
- Heben Sie den Schrank an, um ihn von der Palette zu nehmen.
- Stellen Sie den Schrank am gewünschten Ort auf seinem eigenen Sockel auf.
- Prüfen Sie ihn auf sichtbare Schäden.
- Das Verpackungsmaterial kann den örtlichen Vorschriften gemäß dem Wertstoffkreislauf zugeführt werden.
- Prüfen Sie, dass der Produktcode und die Seriennummer mit den Angaben in den Lieferdokumenten übereinstimmen.

Marke			HOSHIZAKI			
Modellname			PREMIER F 2 A DL DR	PREMIER K/M 2 A DL DR	PREMIER K/M 2 A 2D 2D	PREMIER K/M 2 A 3D 3D
Vorgesehene Verwendung			Storage	Storage	Storage	Storage
Kühltemperatur				X	X	X
Gefriertemperatur			X			
Mehrzweckschrank						
Vertikaler Schrank						
Tischschrank			X	X	X	X
Parameter	Symbol	Unit				
Energieeffizienzklasse	EEC	-	C	A+	A	A
Energieeffizienzindex	EEl	-	40,26	13,9	17,42	17,85
Energieverbrauch in 24 Stunden	E24h	kWh	3,862	0,869	1,069	1,069
Jährlicher Energieverbrauch	AEC	kWh	1410	317	390	390
Nettovolumen für Fach 1	Vn1	litre	96	96	88	77,5
Nettovolumen für Fach 2	Vn2	litre	96	96	88	77,5
Nettovolumen für Fach 3	Vn3	litre	-	-	-	-
Nettovolumen für Fach 4	Vn4	litre	-	-	-	-
Nettovolumen gesamt	VnT	litre	192	192	176	155
Klimaklasse	CC		5	5	5	5
			R290	R600a	R600a	R600a
Kältemittel		kg	0.055	0.07	0.07	0.07
Ladung			3	3	3	3
GWP		CO ₂	0,165	0,21	0,24	0,21
CO ₂ -Äquivalent			X	X	X	X
Hochleistungsbetrieb; dieses Gerät ist für die Verwendung bei Umgebungstemperaturen bis zu 40 °C vorgesehen	HOSHIZAKI EUROPE B.V. Address: Burgemeester Stramanweg 101 1101 AA Amsterdam, The Netherlands Tel.: +31 (0)20 691 84 99 - http://hoshizaki.europe.com/					

HOSHIZAKI

PREMIER UNDERCOUNTER



Marke			HOSHIZAKI			
Modellname			PREMIER F 3 A DL DL DR	PREMIER K/M 3 A DL DL DR	PREMIER K/M 3 A 2D 2D 2D	PREMIER K/M 3 A 3D 3D 3D
Vorgesehene Verwendung			Storage	Storage	Storage	Storage
Kühltemperatur				X	X	X
Gefriertemperatur			X			
Mehrzweckschrank						
Vertikaler Schrank						
Tischschrank			X	X	X	X
Parameter	Symbol	Unit				
Energieeffizienzklasse	EEC	-	C	A	A	A
Energieeffizienzindex	EEl	-	47,98	18,77	21,29	22,02
Energieverbrauch in 24 Stunden	E24h	kWh	5,340	1,299	1.438	1.438
Jährlicher Energieverbrauch	AEC	kWh	1949	474	525	525
Nettovolumen für Fach 1	Vn1	litre	96	96	88	77,5
Nettovolumen für Fach 2	Vn2	litre	96	96	88	77,5
Nettovolumen für Fach 3	Vn3	litre	96	96	88	77,5
Nettovolumen für Fach 4	Vn4	litre	-	-	-	-
Nettovolumen gesamt	VnT	litre	288	288	264	232
Klimaklasse	CC		5	5	5	5
			R290	R290	R290	R290
Kältemittel		kg	0.055	0.065	0.065	0.065
Ladung			3	3	3	3
GWP		CO ₂	0,165	0,195	0,195	0,195
CO ₂ -Äquivalent			X	X	X	X
Hochleistungsbetrieb; dieses Gerät ist für die Verwendung bei Umgebungstemperaturen bis zu 40 °C vorgesehen	<p>HOSHIZAKI EUROPE B.V.</p> <p>Address: Burgemeester Stramanweg 101 1101 AA Amsterdam, The Netherlands Tel.: +31 (0)20 691 84 99 - http://hoshizaki.europe.com/</p>					

HOSHIZAKI

PREMIER UNDERCOUNTER



Marke			HOSHIZAKI			
Modellname			PREMIER F 4 A DL DL DR DR	PREMIER K/M 4 A DL DL DR DR	PREMIER K/M 4 A 2D 2D 2D 2D	PREMIER K/M 4 A 3D 3D 3D 3D
Vorgesehene Verwendung			Storage	Storage	Storage	Storage
Kühltemperatur				X	X	X
Gefriertemperatur			X			
Mehrzweckschrank						
Vertikaler Schrank						
Tischschrank			X	X	X	X
Parameter	Symbol	Unit				
Energieeffizienzklasse	EEC	-	C	A	A	A
Energieeffizienzindex	EEl	-	44,77	17,37	21,87	22,79
Energieverbrauch in 24 Stunden	E24h	kWh	5,67	1,319	1,612	1,612
Jährlicher Energieverbrauch	AEC	kWh	2070	481	588	588
Nettovolumen für Fach 1	Vn1	litre	96	96	88	77,5
Nettovolumen für Fach 2	Vn2	litre	96	96	88	77,5
Nettovolumen für Fach 3	Vn3	litre	96	96	88	77,5
Nettovolumen für Fach 4	Vn4	litre	96	96	88	77,5
Nettovolumen gesamt	VnT	litre	384	384	352	310
Klimaklasse	CC		4	5	4	4
			R290	R290	R290	R290
Kältemittel		kg	0.055	0.065	0.065	0.065
Ladung			3	3	3	3
GWP		CO ₂	0,165	0,195	0,195	0,195
CO ₂ -Äquivalent				X		
Hochleistungsbetrieb; dieses Gerät ist für die Verwendung bei Umgebungstemperaturen bis zu 40 °C vorgesehen	<p>HOSHIZAKI EUROPE B.V.</p> <p>Address: Burgemeester Stramanweg 101 1101 AA Amsterdam, The Netherlands</p> <p>Tel.: +31 (0)20 691 84 99 - http://hoshizaki.europe.com/</p>					



PREMIER UNDERCOUNTER

II. BEDIENUNGSANLEITUNG

ELEKTRIZITÄT

Vor dem Anschließen des Produkts an das Stromnetz sollten Sie prüfen, dass die auf dem Produktbeschreibungsetikett vorgegebene Stromversorgung der lokalen Netzversorgung entspricht.

Das Produktbeschreibungsetikett mit der vorgegebenen Stromversorgung befindet sich im Inneren des Schrank oben links.

Die Installation des Produkts darf nur von qualifizierten und geschulten Wartungskräften gemäß den Vorgaben in dieser Anleitung durchgeführt werden.

Die elektrische Sicherheit dieses Schrank ist nur gegeben, wenn er gemäß den aktuellen örtlichen Gesetzen und Vorschriften geerdet ist.

Die Erdung des Produkts ist in jedem Fall erforderlich.

Der Hersteller haftet nicht für Schäden, die sich aus fehlerhafter Erdung ergeben.

Halten Sie alle Anforderungen bezüglich der Stromversorgung gemäß den örtlichen Vorschriften ein. Der Netzstecker des Produkts und die Steckdose müssen den passenden Erdungsanschlusswert aufweisen. Ziehen Sie bei Bedarf einen qualifizierten Elektriker hinzu.

ALLGEMEINE VORBEREITENDE PRÜFUNGEN

Der Schrank muss aufrecht auf einem ebenen Boden stehen. Bei Bedarf können die einstellbaren Füße zur Nivellierung verwendet werden. Alle Füße müssen in Bodenkontakt sein. Dies ist für den einwandfreien Betrieb der Schranktür erforderlich.

Stellen Sie den Schrank nicht in der Nähe von Wärme erzeugenden Geräten wie einem Ofen, einem Grill oder einer Fritteuse auf. Setzen Sie den Schrank keinem direkten Sonnenlicht aus. Der Schrank ist mit geeignetem Isoliermaterial vor von den Wänden oder dem Boden abgestrahlter Wärme zu schützen. Der Schrank muss so weit wie möglich von jeder Wärmequelle entfernt aufgestellt werden.

Wird der Schrank umgestellt, so warten Sie drei Stunden, bevor Sie ihn wieder einschalten. Entfernen Sie Kunststoffschutz und Klebeband von der Außenseite.

Sorgen Sie dafür, dass der Schrank so aufgestellt wird, dass genügend frische Luft zum Kühlkreislauf und zu den Oberflächen des Schrank gelangen und davon abgeleitet werden kann. Lassen Sie über dem Schrank mindestens 500 mm Platz.

Wenn zwei Kühl- oder Gefrierschränke nebeneinander aufgestellt werden, lassen Sie mindestens 50 mm Platz zwischen ihnen.

Die Belüftungsöffnungen dürfen nicht blockiert werden.

VORBEREITENDE PRÜFUNGEN DER ELEKTRIK

- Prüfen Sie, dass die Netzspannung und die Frequenz der Steckdose mit den Angaben auf dem Produktbeschreibungsetikett übereinstimmen.
- Der Schrank wird mit einer 13- bis 16-Ampere-Sicherung in Reihe mit einer Netzsteckdose verbunden.
- Schalten Sie die mit dem Netzkabel verbundene Netzstromsicherung aus.
- Prüfen Sie, dass der Stecker am Schrank für die Verwendung mit der verfügbaren Netzsteckdose geeignet ist und sie zusammen passen.

PREMIER UNDERCOUNTER

ERSTE INBETRIEBNAHME UND KONTROLLEN

Der Schrank kann nach Abschluss der obenstehenden Prüfungen in Betrieb genommen werden. Der EIN/AUS-Schalter schaltet den Schrank ein.

Nach dem Einschalten des Schanks nimmt der Kompressor seinen Betrieb auf. Der Kompressor arbeitet, bis die werkseitig voreingestellte Temperatur erreicht ist. Lebensmittel sollten erst in den Schrank gelegt werden, wenn eine für die zu kühlenden Lebensmittel geeignete Temperatur eingestellt wurde.

Die neue Temperatur kann mithilfe der Steuerung wie in dieser Anleitung beschrieben eingestellt werden.



WICHTIG

- Legen Sie erst dann Lebensmittel in das Produkt, wenn es sich auf die eingestellte Temperatur abgekühlt hat.
- Die maximale Aufnahmekapazität darf nicht überschritten werden. Die maximale Tragfähigkeit der Regale beträgt 40 kg pro Regal bei gleichmäßiger Belastung in aufrecht gestellten Schränken und 20 kg bei Regalen und Schubladen in Tischschränken.
- Lesen Sie den Abschnitt „Allgemeine vorbereitende Prüfungen“ dieser Anleitung für Informationen zum Platzbedarf um das Produkt für eine gute Belüftung.
- Lagern Sie keine explosiven Stoffe wie Spraydosen mit einem brennbaren Treibmittel in diesem Schrank.
- Bei einer 1/3-Schublade kann der Behälterdeckel mit Dichtungsausrüstung nicht verwendet werden.

WARNUNG:

- Blockieren Sie niemals die Belüftungsöffnungen am Gerät.
- Zum Beschleunigen des Abtauvorgangs ausschließlich die vom Hersteller empfohlenen mechanischen Geräte oder anderen Mittel verwenden.
- Den Kältekreislauf nicht beschädigen.
- Verwenden Sie im Inneren des Schanks keine elektrischen Geräte.
- Bitte beschädigen Sie nicht das Netzkabel, die Verkabelung oder andere wichtige Schlüsselkomponente.

AUFBEWAHRUNGSBEDINGUNGEN UND LEISTUNG

Die richtigen Aufbewahrungsbedingungen sind nicht nur für Lebensmittelhygiene und -sicherheit entscheidend, sondern verbessern auch die Leistung und reduzieren den Energieverbrauch. Die beste Leistung lässt sich durch Beachtung der folgenden Tipps und Hinweise erzielen: Legen Sie Lebensmittel nur auf die Regale und niemals auf den Boden des Schanks. Lebensmittel sollten so in den Schrank gelegt werden, dass Luft um sie herum zirkulieren kann; lassen Sie daher Platz zwischen den Lebensmitteln und den Wänden des Produkts. Der Abstand zwischen den Regalen lässt sich bei Bedarf ändern.

PREMIER UNDERCOUNTER

III. BEDIENFELD

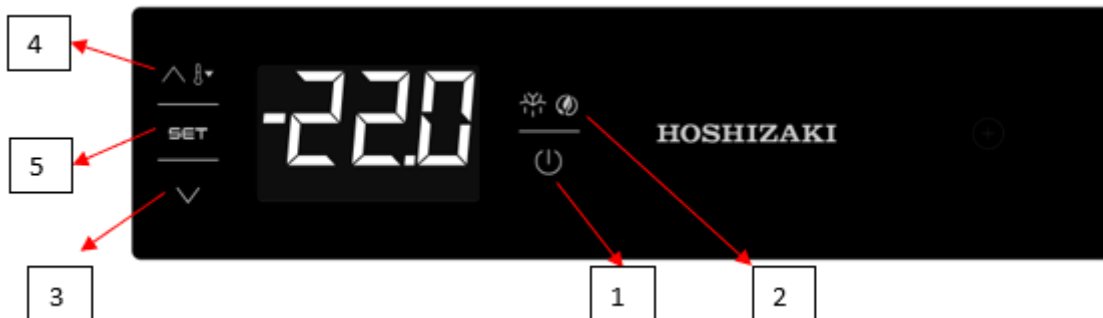

➤ FUNKTIONEN AN DER FRONTPLATTE

Zum Sperren der Tasten am vorderen Bedienfeld AUX (3) gedrückt halten und Ein / Standby (1) 2 Sekunden lang gedrückt halten: Wenn die Tasten gesperrt sind, wird die Angabe „Loc“ angezeigt; sind sie nicht verriegelt, wird die Angabe „UnL“ angezeigt.

- 1) Das Gerät kann geöffnet oder geschlossen werden, indem **EIN/STANDBY** 4 Sekunden lang gedrückt gehalten wird. (Ein/Aus)
- 2) **MANUELLES ABTAUEN**: Wird diese Taste 4 Sekunden lang gedrückt, so beginnt die manuelle Abtauung. Allerdings startet die manuelle Abtauung nicht im Falle der Starkkühlung und einer ungeeigneten Verdampfertemperatur.
- 3) **ABWÄRTS**-Taste: Zum Durchlaufen des Menüs nach unten oder Reduzieren eines Werts. Wird diese Taste 4 Sekunden lang gedrückt, aktiviert dies die Superkühlung. Bei aktiver Starkkühlungsfunktion kann die eingestellte Temperatur gesenkt werden; Zeit und Temperatur werden anhand der Parameter bestimmt. Bei aktiver Starkkühlungsfunktion findet keinerlei Abtauung statt.
- 5) **AUFWÄRTS**-Taste: Zum Durchlaufen des Menüs nach oben oder Erhöhen eines Werts. Wird diese Taste 4 Sekunden lang gedrückt, so aktiviert dies die Funktion für geringen und hohen relativen Luftfeuchtigkeitsgehalt. (Nur bei einigen Modellen) Die Anzeige „rHL“ erscheint (Funktion für geringe relative Luftfeuchtigkeit ist aktiv) oder die Anzeige „rH“ erscheint (Funktion für hohe relative Luftfeuchtigkeit ist aktiv). Diese Funktionen werden 10 Sekunden lang angezeigt. Falls keine Luftfeuchtigkeitssteuerung stattfindet, erscheint 1 Sekunde lang die Anzeige „- ---“.
- 6) **SET**-Taste: Eingabe- und Änderungstaste für einstellbare Werte.

➤ BETRIEB

Folgende Betriebssituationen existieren:

Status „Ein“: Das Gerät wird mit Strom versorgt und arbeitet.

Status „Standby“: Das Gerät ist ausgeschaltet, wird aber weiterhin mit Strom versorgt.

Status „Aus“: Zum Ausschalten des Geräts den Stecker aus der Steckdose ziehen oder den Hauptschutzschalter ausschalten.

HOSHIZAKI

PREMIER UNDERCOUNTER



IV. WARTUNGSANLEITUNG

Das Gerät muss regelmäßig gereinigt werden. Diese Intervalle hängen vom Nutzungs- und Verschmutzungsgrad ab (mindestens einmal jährlich).



Vor einer Reinigung oder Wartung das Gerät immer zuerst ausstecken



Die Maschinenteile nicht berühren oder befeuchten. Dies könnte zu Störungen oder Ausfall führen.



Um Beschädigungen zu vermeiden, Kunststoffteile nicht mit über 40 °C heißem Wasser oder in einem Geschirrspüler reinigen.

Schrankinnenraum und außen sowie Regale



Für einen hygienischen Gebrauch den Innenraum und die Außenseite mindestens einmal pro Woche reinigen.



Das Gerät innen und außen mit einem weichen, in einer kalten oder warmen Neutralseifenlösung angefeuchteten und gut ausgewringenen Tuch reinigen. Zur Reinigung des Maschinenteils keinen Wasserstrahl verwenden.



Andere chemische Lösungsmittel als Neutralreiniger könnten die Innen- und Außenflächen beschädigen.



Reinigungsmittelrückstände führen zu Beschädigung an Metall- oder Kunststoffoberflächen. Zum Abwischen ein weiches, mit warmem Wasser befeuchtetes Tuch verwenden.



Die folgenden Mittel nicht verwenden. Sie können Lack- oder Kunststoffoberflächen beschädigen:

- Polierpulver, Alkohol, Verdünnung, Benzol, säure- oder laugenhaltige Reinigungsmittel, heißes Wasser, Petroleum, Seifenpulver, Metallschwämme oder -bürsten, usw. Besonders Reinigungsmittel zum Entfernen von Fett an Ventilatoren oder Mikrowellen

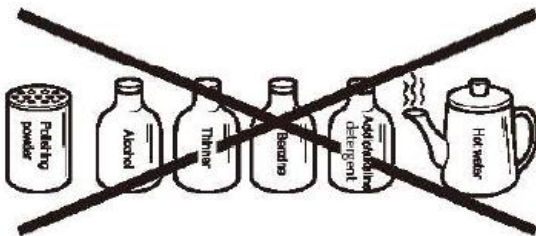

Hinweis: **Auch einige andere als die oben aufgeführten Mittel können Lack- oder Kunststoffoberflächen beschädigen. Falls Probleme auftreten, den Gebrauch solcher Mittel sofort einstellen!**



Die Türdichtung und ihre Kontaktfläche verschmutzen sehr leicht. Alle Oberflächen dieser Teile daher gründlich reinigen. Lebensmittelreste beschleunigen den Verschleiß.



Mit einem Tuch alle Wasserrückstände im Schrank abwischen.

HOSHIZAKI

PREMIER UNDERCOUNTER



Verflüssiger



Einen Staubsauger oder eine weiche Bürste verwenden, um Staub und Schmutz vom Verflüssiger zu entfernen.



Warnung: **Wird der Verflüssiger mit einer harten Bürste wie etwa einer Geschirrspülbürste gereinigt, kann sich seine Beschichtung ablösen.**

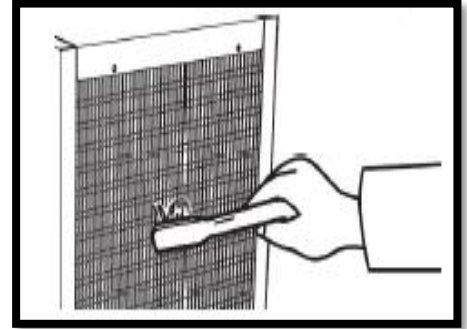

Luftfilter



Zur Vermeidung von Deformation den Luftfilter nicht mit über 40 °C heißem Wasser abwaschen



Siebfilter aus Kunststoff entfernen Schmutz oder Staub aus der Luft und verhindern das Verstopfen des Verflüssigers. Mit zunehmender Verstopfung der Filter verringert sich die Leistung des Kühl-/Gefrierschranks.



Den Filter mindestens zweimal im Monat überprüfen. Bei starker Verstopfung oder wenn die Anzeige „CH“ erscheint, sind die Filter mit warmem Wasser und einem Neutralreiniger zu waschen. Das Gerät nicht mit ausgebauten Luftfiltern betreiben, da sich sonst der Verflüssiger verstopft. Dies verursacht Störungen.

- 1) Die Frontplatte öffnen und den Luftfilter herausnehmen. Kühlrippen des Verflüssigers nicht berühren, da sonst Verletzungsgefahr besteht.
- 2) Den Luftfilter sorgfältig mit kaltem oder warmem Wasser mit der geeigneten Menge Neutralreiniger waschen. Den Luftfilter gründlich abspülen und trocknen.
- 3) Zum erneuten Einsetzen des Luftfilters die beiden Laschen in den Wärmetauscher oder die Rippen im Verflüssiger stecken und so den Luftfilter fest über dem Verflüssiger anbringen.

HOSHIZAKI

PREMIER UNDERCOUNTER



V. TECHNISCHE INFORMATIONEN GERÄTEABMESSUNGEN

PREMIER K-M-F 2 A DL DR L

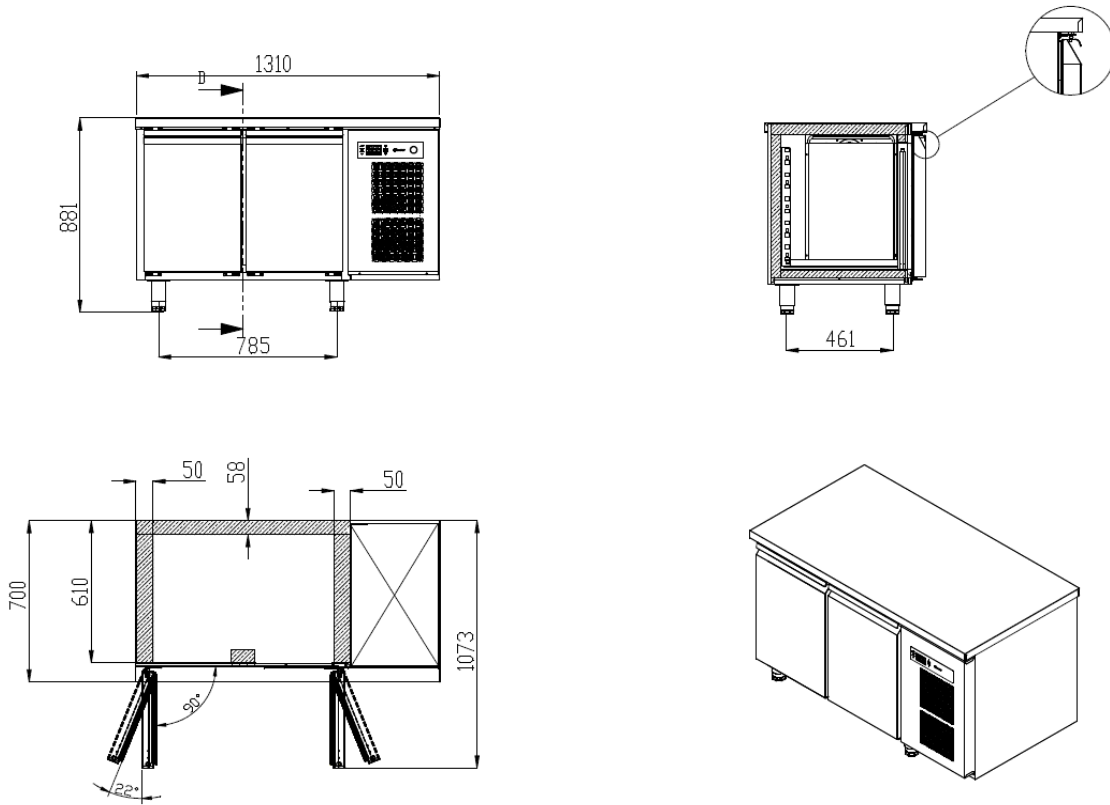

PREMIER K-M-F 2 A DL DR C

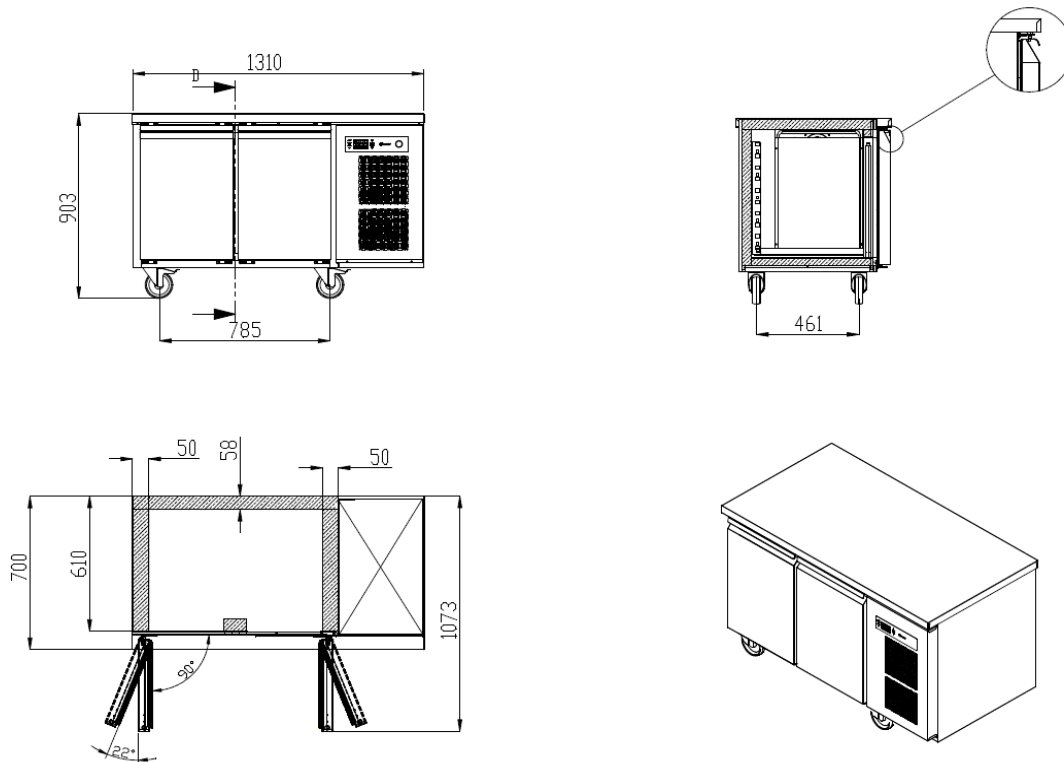

HOSHIZAKI

PREMIER UNDERCOUNTER



PREMIER K-M 2 A 2D 2D L

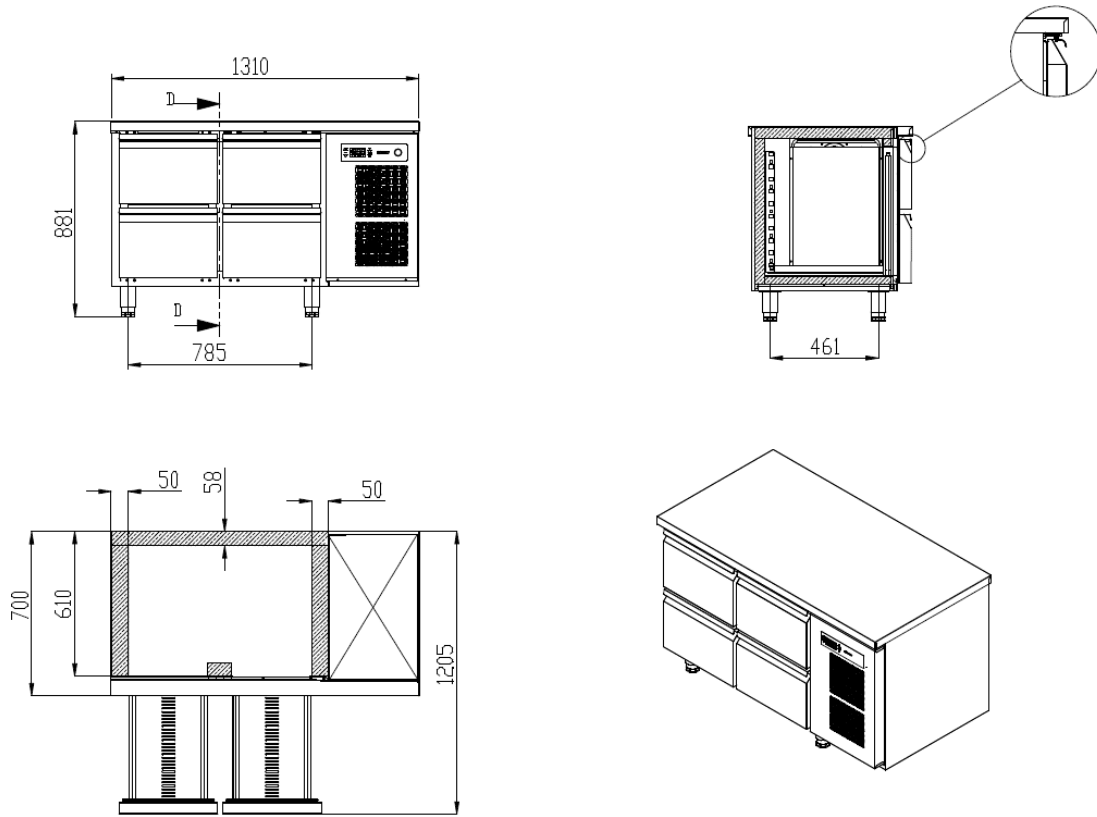

PREMIER K-M 2 A 2D 2D C

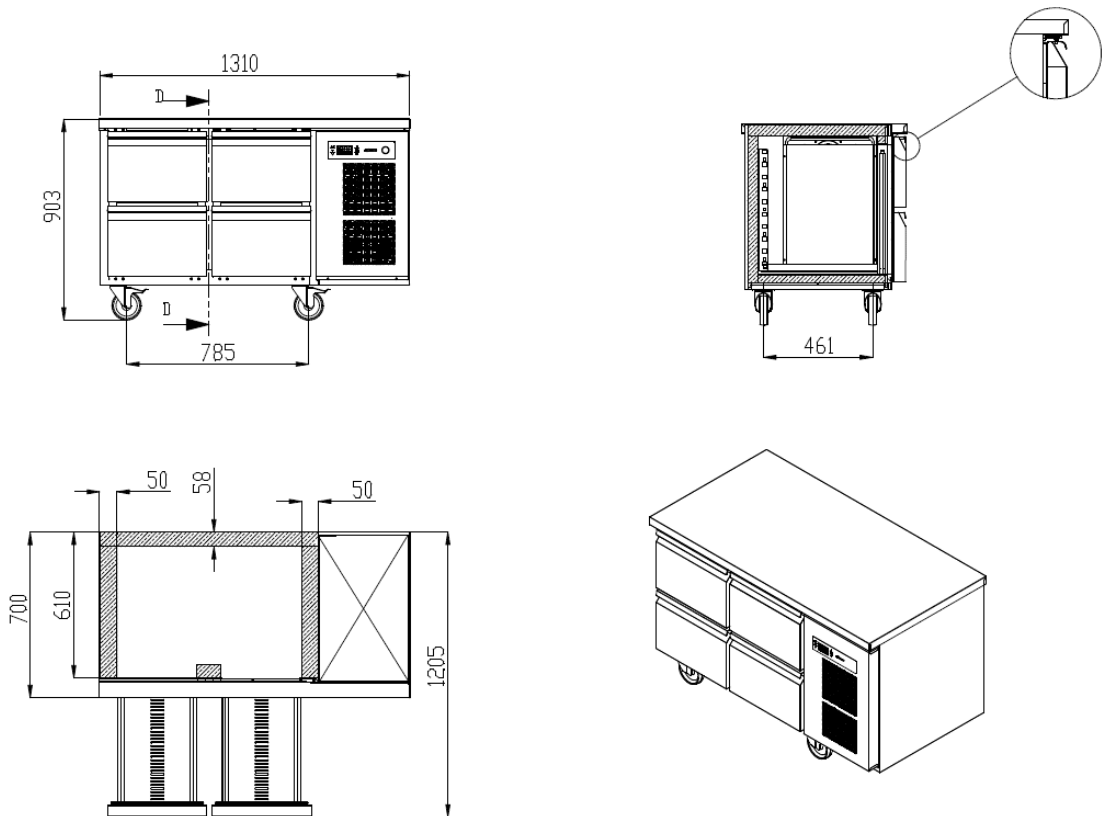

HOSHIZAKI

PREMIER UNDERCOUNTER



PREMIER K-M 2 A 3D 3D L

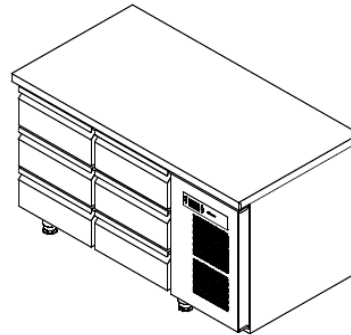
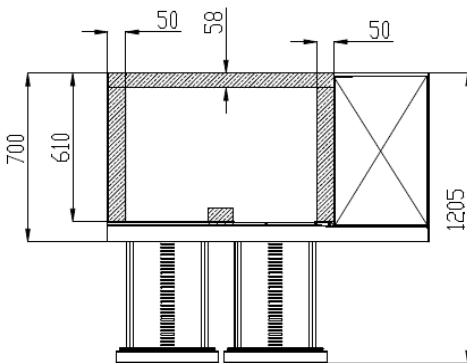
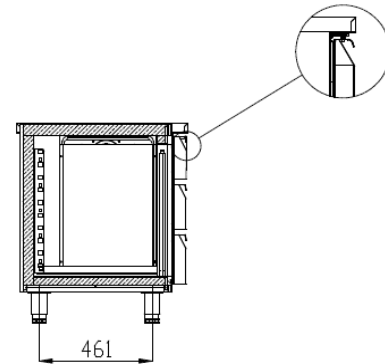
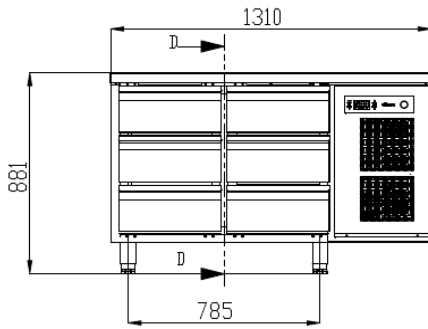

PREMIER K-M 2 A 3D 3D C

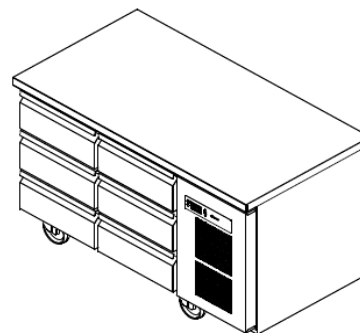
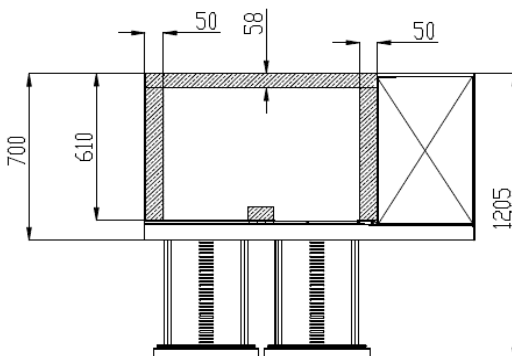
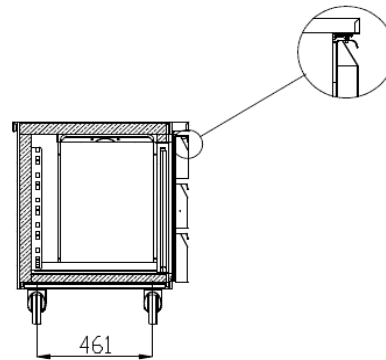
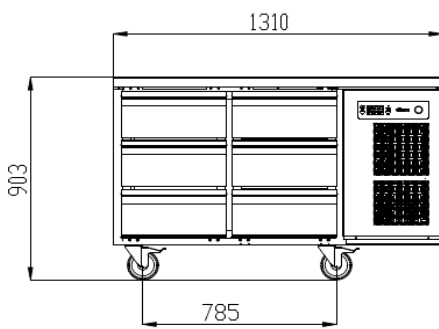

HOSHIZAKI

PREMIER UNDERCOUNTER



PREMIER K-M-F 3 A DL DR DR L

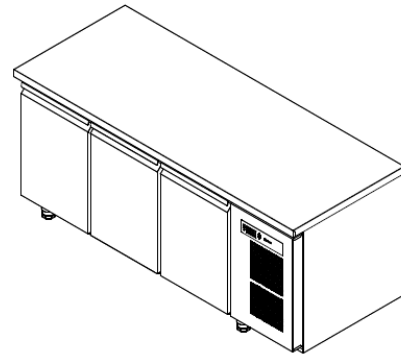
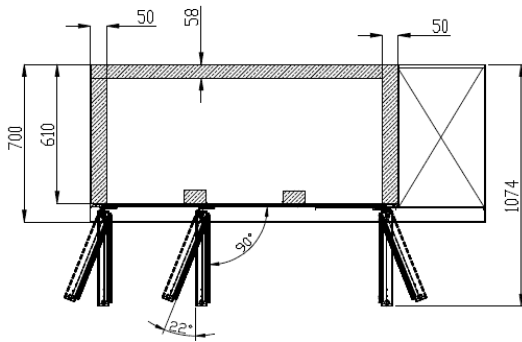
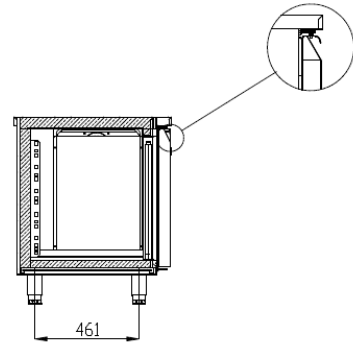
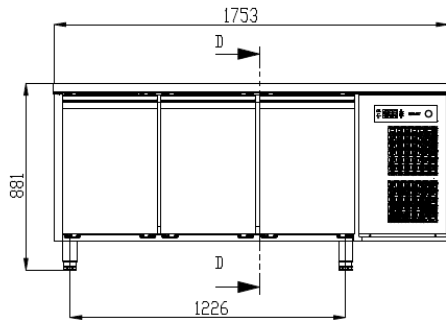

PREMIER K-M-F 3 A DL DR DR C

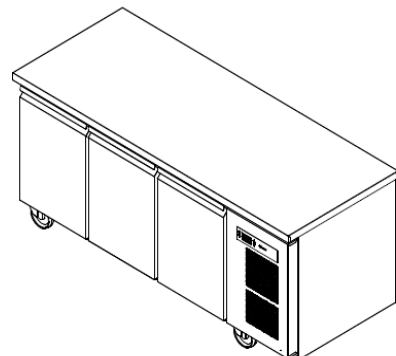
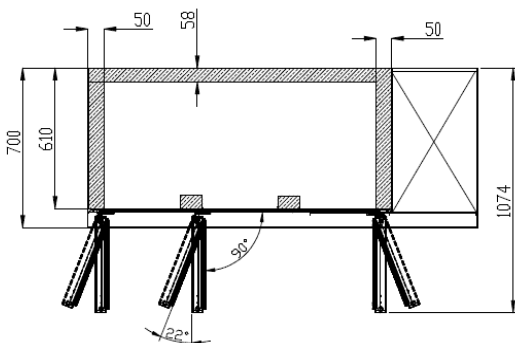
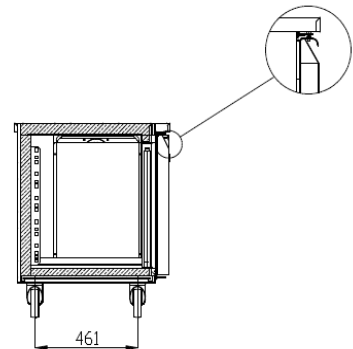
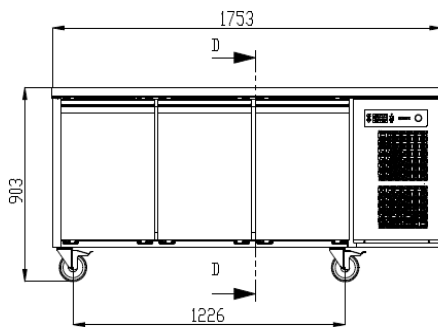

HOSHIZAKI

PREMIER UNDERCOUNTER



PREMIER K-M 3 A 2D 2D 2D L

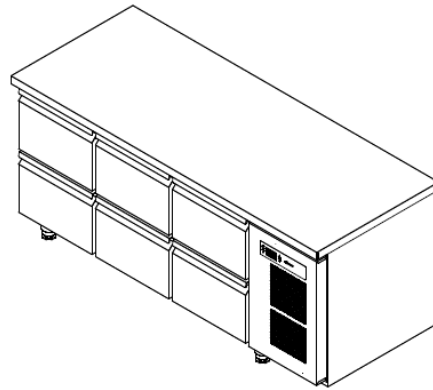
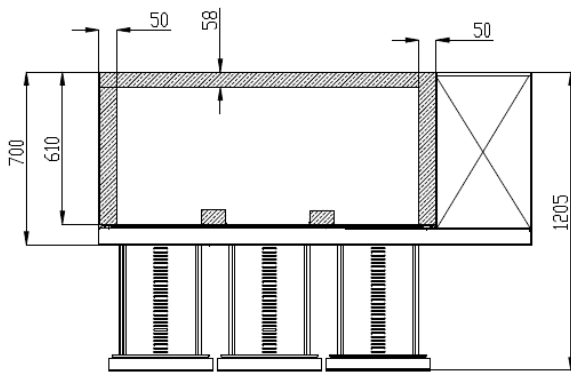
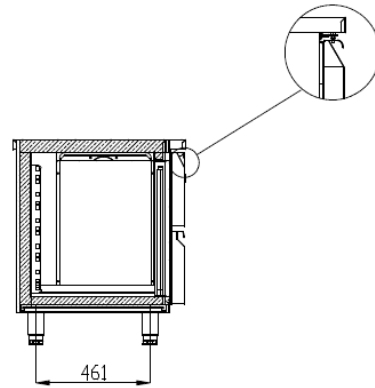
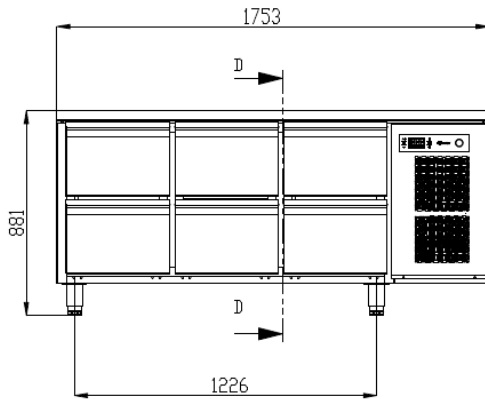

PREMIER K-M 3 A 2D 2D 2D C

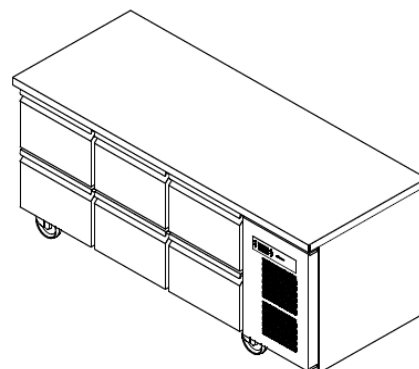
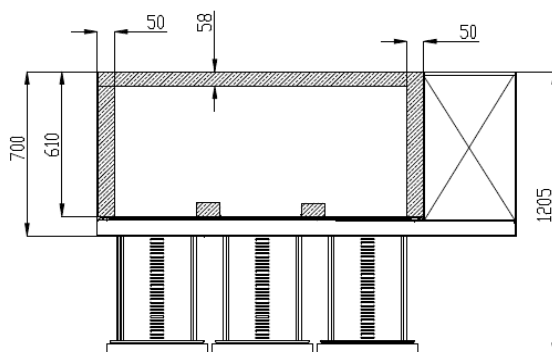
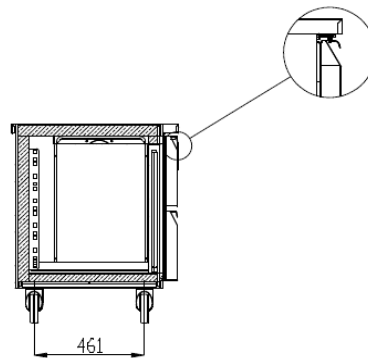
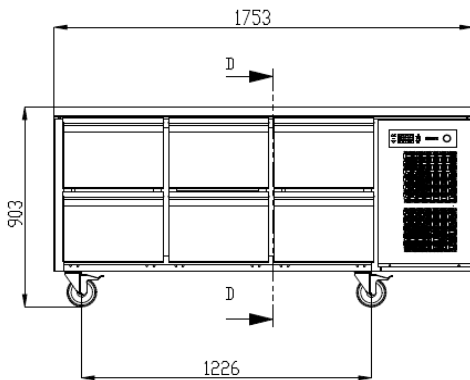

HOSHIZAKI

PREMIER UNDERCOUNTER



PREMIER K-M 3 A 3D 3D 3D 3 L

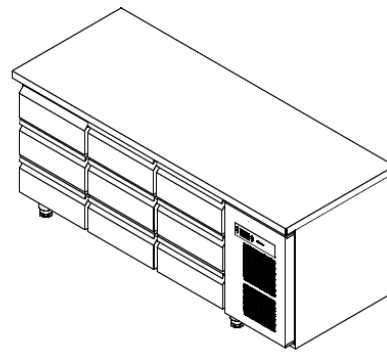
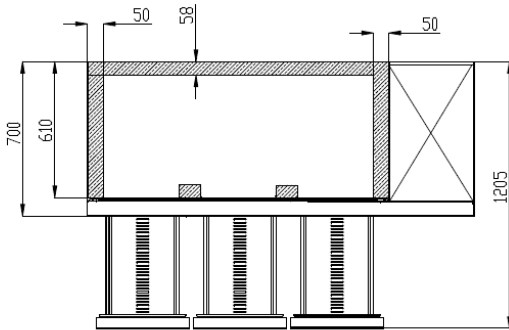
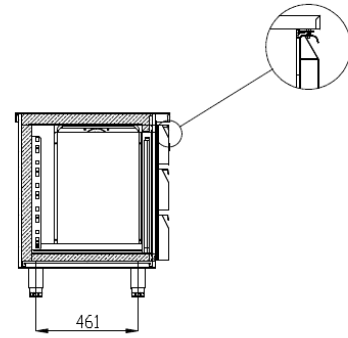
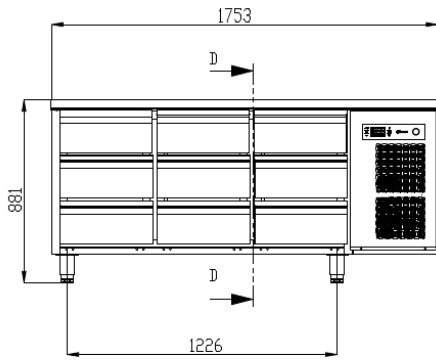

PREMIER K-M 3 A 3D 3D 3D C

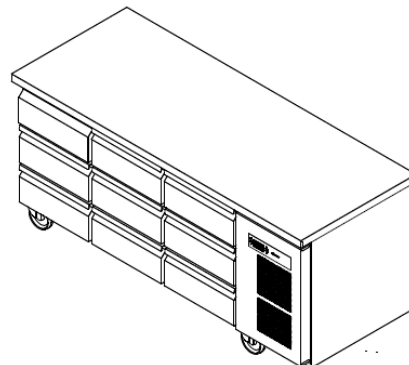
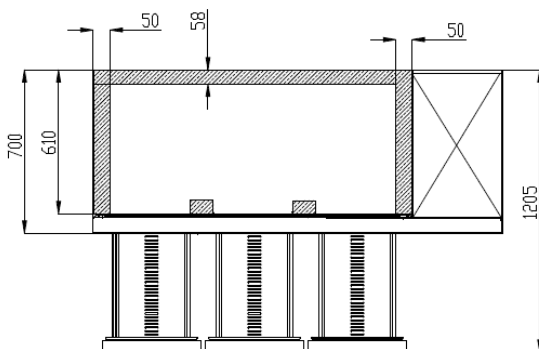
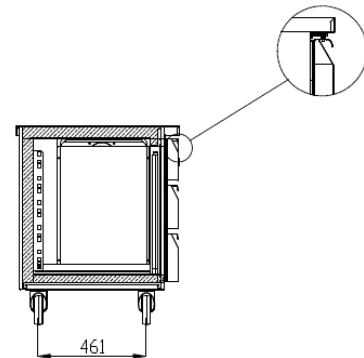
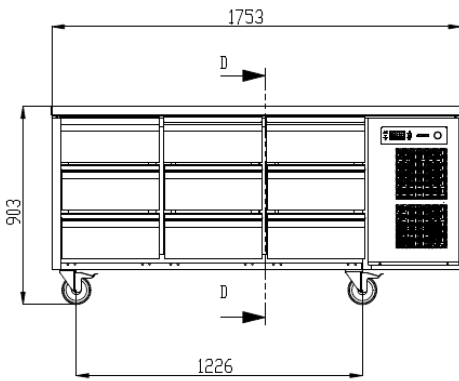

HOSHIZAKI

PREMIER UNDERCOUNTER



PREMIER K-M-F 4 A DL DL DR DR L

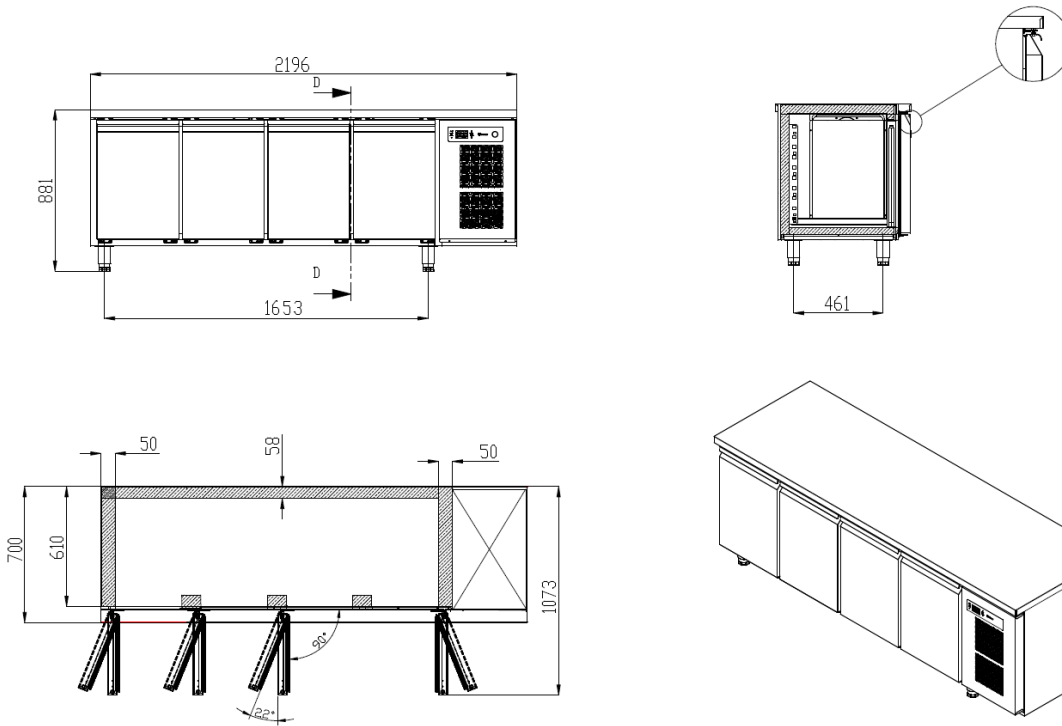

PREMIER K-M-F 4 A DL DL DR DR C

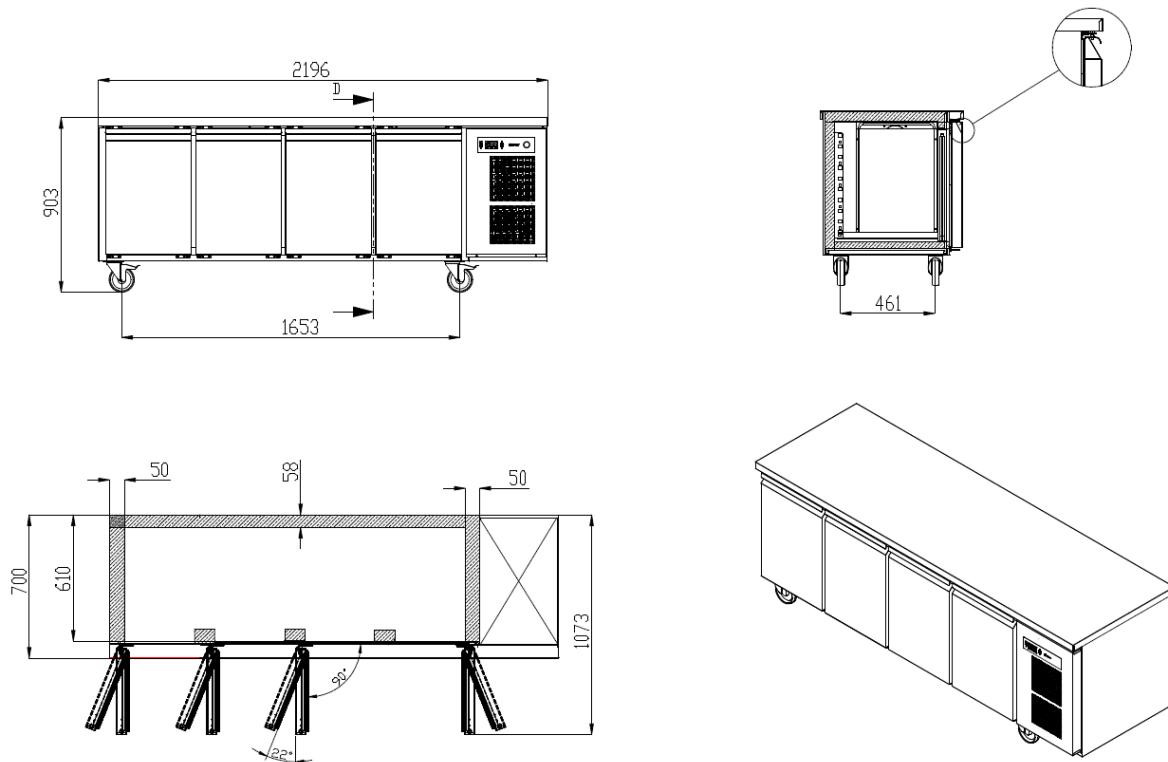

HOSHIZAKI

PREMIER UNDERCOUNTER



PREMIER K-M 4 A 2D 2D 2D 2D L

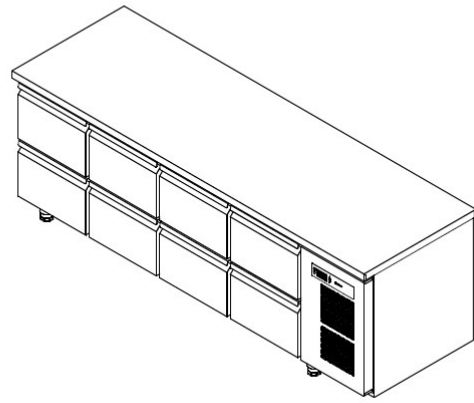
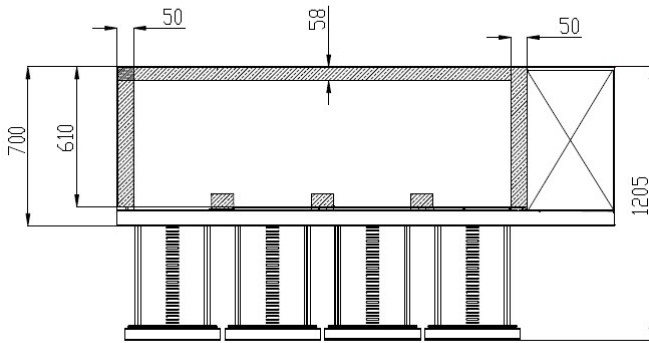
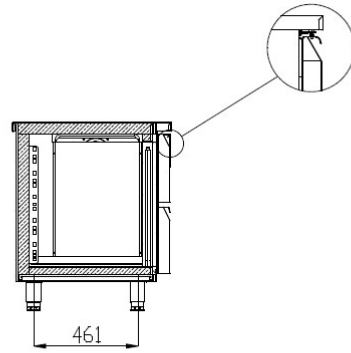
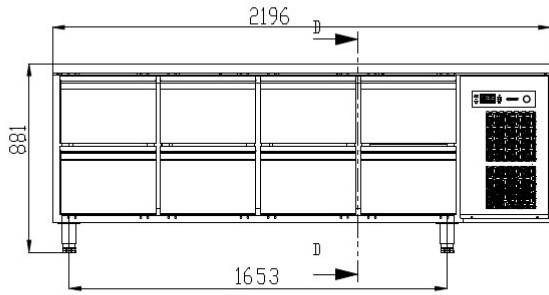

PREMIER K-M 4 A 2D 2D 2D 2D C

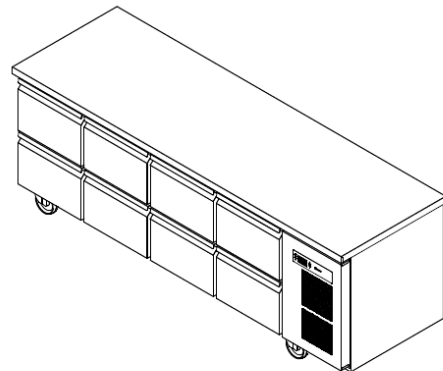
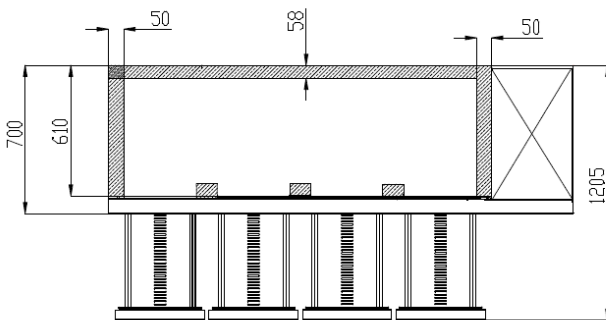
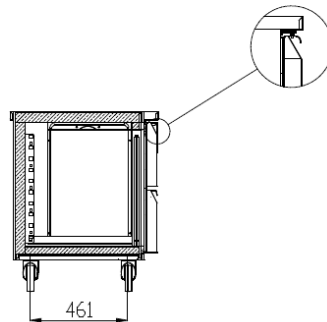
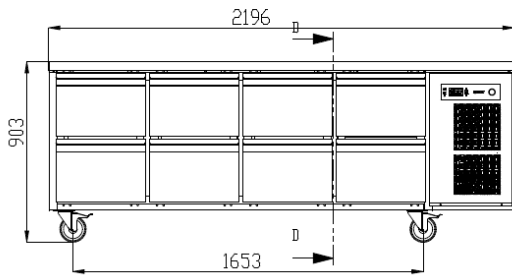

HOSHIZAKI

PREMIER UNDERCOUNTER



PREMIER K-M 4 A 3D 3D 3D 3D L

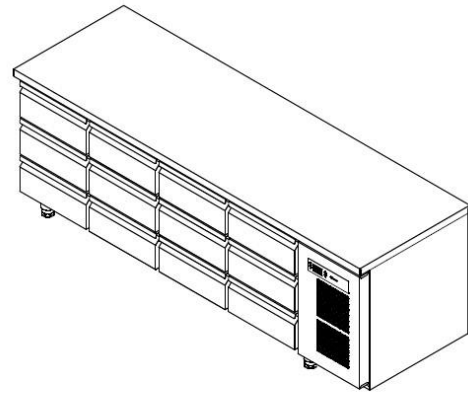
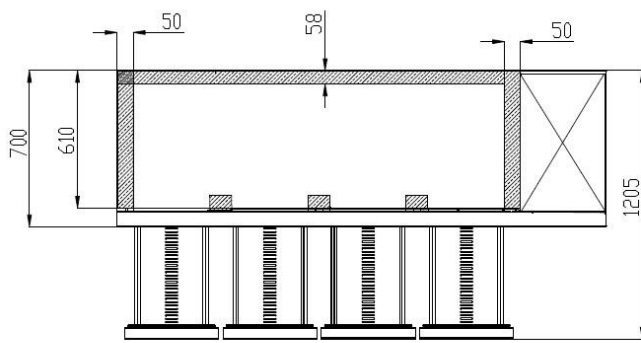
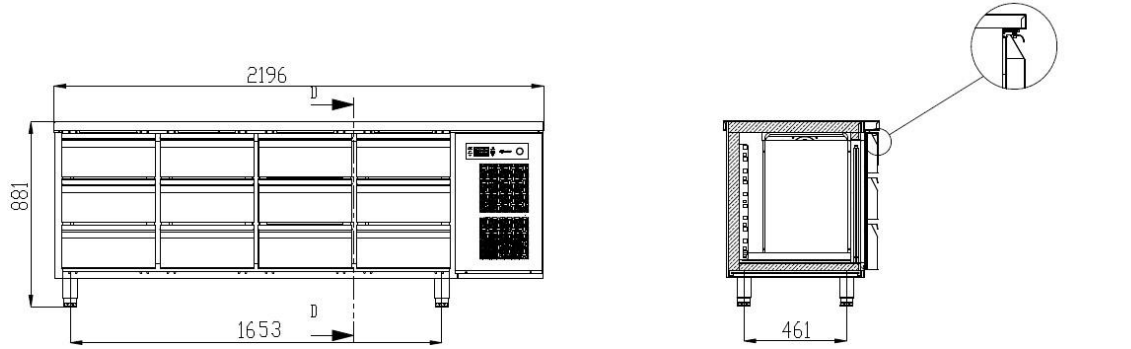

PREMIER K-M 4 A 3D 3D 3D 3D C

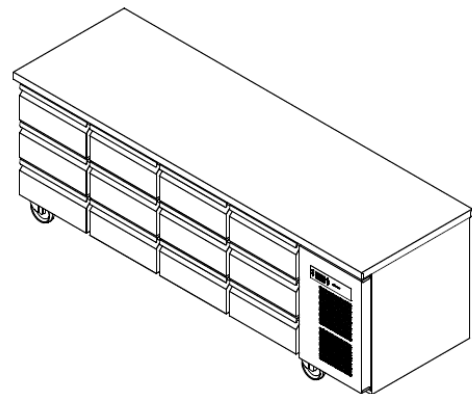
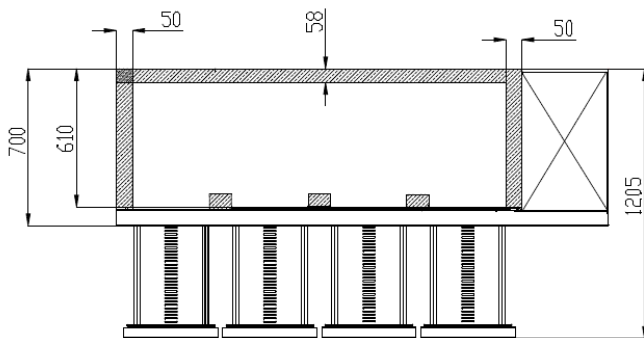
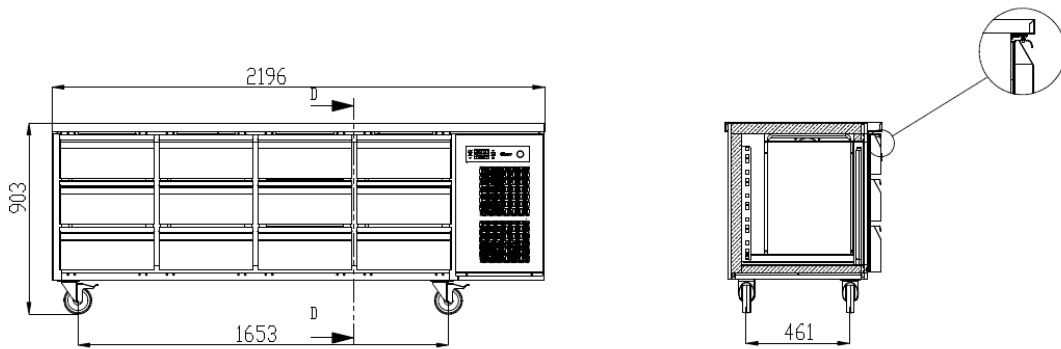

HOSHIZAKI

PREMIER UNDERCOUNTER



VI. KÜHLUNGSDIAGRAMM & SCHALTBILD

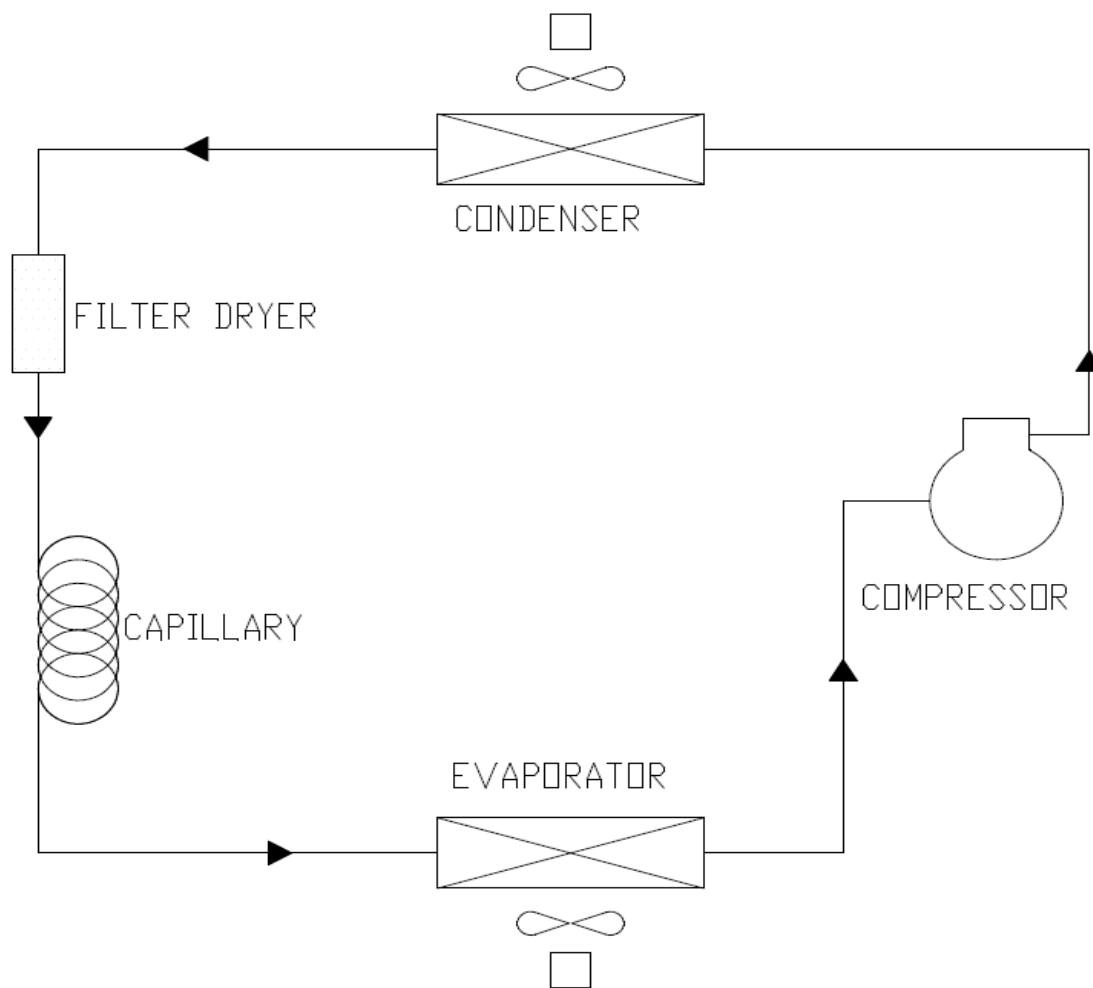



HOSHIZAKI

PREMIER UNDERCOUNTER

SCHALTBILD

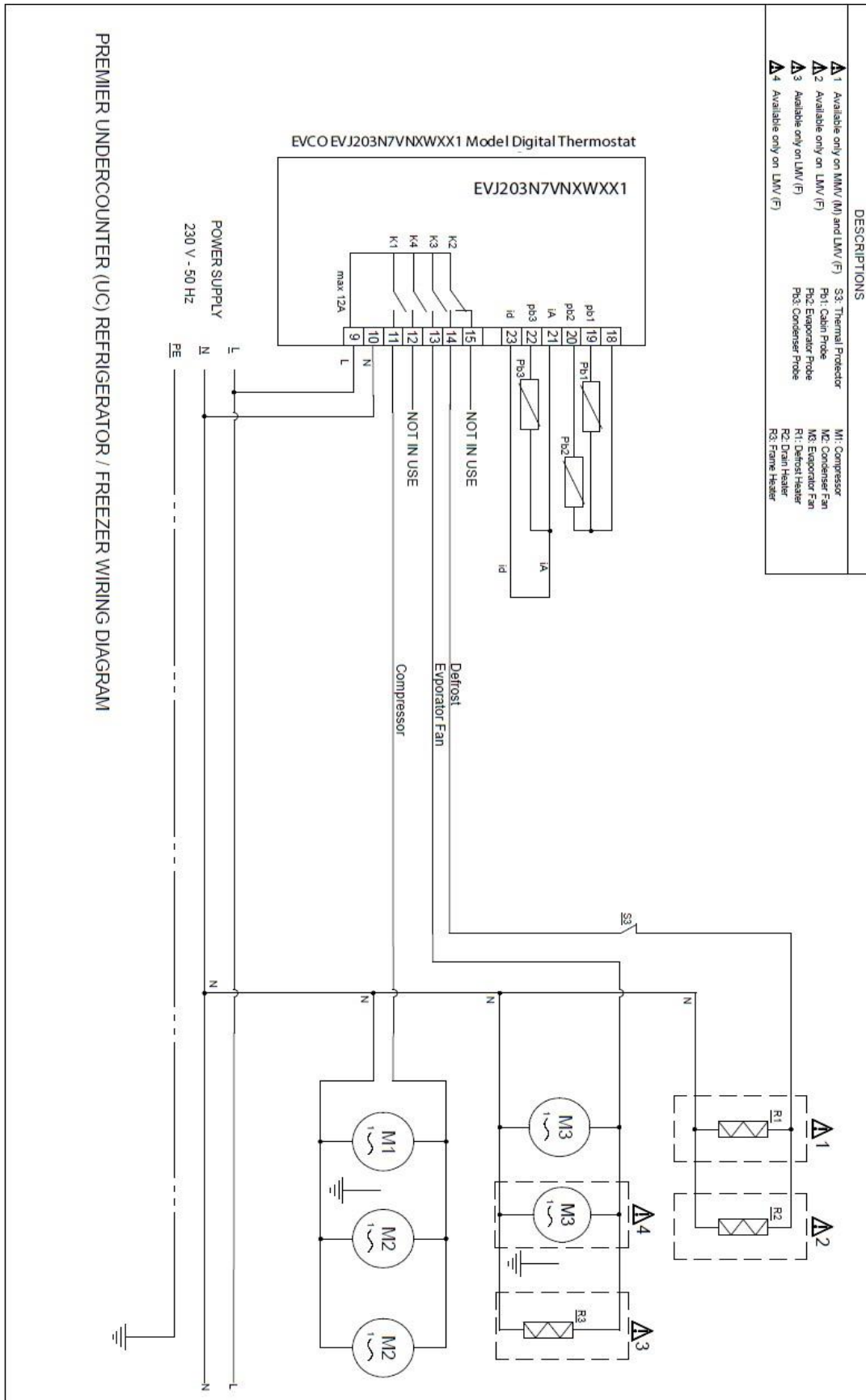

PREMIER UNDERCOUNTER

VII. FEHLERSUCHE

In der Tabelle unten sind einige Probleme aufgeführt, die auftreten können. Wenn ein Alarmcode angezeigt wird, ist eine Störung aufgetreten. Beheben Sie alle möglichen Ursachen, bevor Sie den Schrank zurücksetzen. Mögliche Ursachen und Abhilfemaßnahmen sind unten aufgeführt.

Wenn ein Fehlercode auch nach Durchführung der folgenden Prüfungen weiterhin angezeigt wird, wenden Sie sich an einen zugelassenen Techniker. Sie müssen die Art der Fehlermeldung feststellen. Auf dem Typenschild des Produkts finden Sie Angaben zum Produkt wie etwa die Seriennummer.

PROBLEM	MÖGLICHE URSACHE	LÖSUNG	
Der Schrank funktioniert nicht	Der Schrank wird nicht mit Strom versorgt	Prüfen, ob Netzstecker und Kabel in Ordnung sind	
Der Kompressor hört fast nie auf zu arbeiten	Die Umgebungstemperatur ist zu hoch	Die Belüftung muss verbessert werden	
	Der Verflüssiger oder der Verflüssigerfilter ist verstopft	Prüfen und reinigen Sie den Verflüssigerfilter regelmäßig	
	Die Türdichtungen schließen nicht richtig	Einen zugelassenen Techniker rufen, um die Dichtungen austauschen zu lassen	
	Eisbildung am Verdampfer	Keine heißen Lebensmittel in den Schrank legen	
		Keine Lebensmittel mit hohem Wassergehalt in den Schrank legen, solange sie nicht in verschlossenen Behältern aufbewahrt werden	
Verflüssigergebläsefehler	Einen manuellen Abtauzyklus starten	Einen zugelassenen Techniker rufen, um das oder die Gebläse austauschen zu lassen	
Überlaufendes Wasser aus der Verflüssigerwasserschale	Häufiges Abstellen von heißen Lebensmittel im Schrank	Keine heißen Lebensmittel in den Schrank legen	
		Lebensmittel mit hohem Wassergehalt nur in verschlossenen Behältern im Schrank aufbewahren	
	Häufiges Öffnen von Tür oder Schubladen	Prüfen, ob die technischen Daten des Schranks die derzeitige Nutzungsweise zulassen	
Schranktemperatur hoch	Der Verflüssiger ist durch Schmutz und Staub verstopft	Prüfen und reinigen Sie den Verflüssigerfilter regelmäßig	
	Die Luftströmung im Schrank ist blockiert	Lebensmittel entfernen, die die Luftströmung behindern	
	Umgebungsluft dringt in den Schrank ein	Darauf achten, dass die Tür geschlossen ist	
		Dichtungen an Tür und Schubladen auf Schäden prüfen	
Eisbildung am Verdampfer	Einen manuellen Abtauzyklus starten	Einen zugelassenen Techniker rufen	

PREMIER UNDERCOUNTER

VIII. AUSBAU UND AUSTAUSCH ENTSORGUNG DES SCHRANKS

- Am Typenschild ist angegeben, welches Kältegas im Schrank vorhanden ist.
- Der Schrank ist gemäß den EU-Bestimmungen aus wiederverwertbaren Materialien hergestellt. Am Ende seiner Lebensdauer muss der Schrank daher zur Entsorgung zu einer Wertstoffsammelstelle gebracht werden.
- Entsorgen Sie den Schrank nicht als Metall oder Haushaltsmüll.
- Kompaktieren Sie nicht den Kältemittelkreislauf der Kühlanlage.



WICHTIG

Halten Sie sich bei der Entsorgung des Schranks an die örtlichen Vorschriften und Bestimmungen.

HOSHIZAKI

PREMIER UNDERCOUNTER



Alle Rechte vorbehalten. Hoshizaki behält sich das Recht der Änderung von Merkmalen und Informationen in dieser Anleitung vor.

Kontaktangaben

Hauptsitz

Hoshizaki Europe B.V – All other countries in Europe and Africa

TEL: +31 (0)20 6918499

sales@hoshizaki.nl -- <http://hoshizaki-europe.com/>

Niederlassungen

Hoshizaki UK - UK, Ireland

TEL: +44 (0)845 456 05 85

uksales@hoshizaki.co.uk

Hoshizaki Deutschland - Germany, Switzerland, Austria

TEL: +49 (0)5121 697370

vertrieb@hoshizaki.de

Hoshizaki Benelux - Netherlands, Belgium, Luxembourg

TEL: +31 (0)85 0188370

info@hoshizaki.nl

Hoshizaki France - France

TEL: +33 (0)1 48 63 93 80

info@hoshizaki.fr

Hoshizaki Iberia - Spain, Portugal

TEL: +34 (0)93 478 09 52

info@hoshizaki.es

Hoshizaki Denmark - Denmark

TEL: +45 89 88 53 50

salg@hoshizaki.dk

Hoshizaki Norway - Norge

TEL: +47 22 88 17 50

salg@hoshizaki.no

Hoshizaki Sweden - Sverige

TEL: +46 108 84 87 47

OrderSE@hoshizaki.dk

Hoshizaki Italia – Italia

TEL: +39 348 3022156

commerciale@hoshizaki.it

HOSHIZAKI

PREMIER UNDERCOUNTER



HOSHIZAKI

PREMIER UNDERCOUNTER



REFRIGERADORES Y CONGELADORES MANUAL DE OPERACIÓN, MANTENIMIENTO E INSTALACIÓN



I. INFORMACIÓN GENERAL	80
II. INSTRUCCIONES DE FUNCIONAMIENTO	85
III. PANEL DE CONTROL	87
IV. INSTRUCCIONES DE MANTENIMIENTO	88
V. INFORMACIÓN TÉCNICA	90
VI. DIAGRAMA DE REFRIGERACIÓN – ESQUEMA ELÉCTRICO	99
VII. DIAGNÓSTICO DE MANTENIMIENTO Y REPARACIÓN	101
VIII. DESMONTAJE Y SUSTITUCIÓN	102

Datos de contacto:
HOSHIZAKI EUROPE B.V.
Dirección: Burgemeester Stramanweg 101 1101 AA Ámsterdam, Holanda
Tel: +31 (0)20 691 8499 <http://hoshizaki-europe.com/>



PREMIER UNDERCOUNTER

I. INFORMACIÓN GENERAL

ETIQUETA DE DESCRIPCIÓN DEL PRODUCTO

1 - Número de producto
2 - Descripción del producto
3 - Modelo
4 - Refrigerante (GWP)
5 - Equivalente de CO ₂
6 - Protección IP
7 - Clase climática
8 - Fecha de producción
9 - Potencia total / Corriente / Potencia de la lámpara
10 - Voltaje – Frecuencia
11 - Elemento calefactor
12 - Presión del sistema
13 - Agente de soplado
14 - Número de serie

PRODUCT NUMBER	1
PRODUCT DESCRIPTION	2
MODEL	3
REFRIGERANT	4
CO ₂ EQUIVALENT	5
IP PROTECTION	6
CLIMATE CLASS	7
PRODUCTION DATE	8
TOTAL POWER / CURRENT / LAMP POWER	9
VOLTAGE - FREQUENCY	10
HEATING ELEMENT	11
SYSTEM PRESSURE	12
BLOWING AGENT	13

S/N: 14



HOSHIZAKI EUROPE B.V. Burgemeester Stramanweg 101 1101 AA
Amsterdam, The Netherlands



LA FINALIDAD DE USO

- Este producto debe utilizarse en interiores, única y exclusivamente con la finalidad de almacenar alimentos y bebidas. Unidades de almacenamiento diseñadas para mantener el producto ya a la temperatura del frigorífico/congelador.
- El fabricante no se hace responsable por los daños derivados de un uso contrario a lo indicado en este manual.
- Cuando almacene alimentos en este armario, procure que nunca entren en contacto con la estructura del mismo.
- Todos los alimentos deben estar totalmente recubiertos. Para evitar la contaminación y la corrosión de los componentes internos, todo el producto debe envolverse o almacenarse en recipientes herméticos.
- No almacene alimentos o líquidos calientes en este armario.
- Las bebidas almacenadas en cajas y las botellas de cristal no deben almacenarse a temperaturas inferiores a los 0 °C (punto de congelación). Las latas y las botellas de cristal pueden estallar debido a la expansión. Los recipientes con tapas no deben llenarse totalmente: debe dejarse un pequeño espacio para la expansión.
- Este armario está equipado con una función de autodescongelación automática. También es posible realizar una descongelación manual. Para la descongelación manual no es necesario desactivar el armario durante largos períodos de tiempo, sino que puede realizarse a través del controlador. Bajo ninguna circunstancia deben utilizarse herramientas manuales para descongelar este armario, ya que los daños resultantes podrían ser muy difíciles de reparar.
- No utilice ningún medio mecánico ni alternativo de descongelación.
- El aparato no debe ser utilizado por personas (incluidos los niños) con capacidades físicas, sensoriales o mentales reducidas, o con falta de experiencia y conocimientos, o bien que carezcan de experiencia o conocimientos adecuados, a menos que hayan recibido supervisión o instrucciones.

PREMIER UNDERCOUNTER

- Debe vigilarse que los niños no jueguen con el aparato.
- Los niños sin supervisión no deben realizar la limpieza ni el mantenimiento de usuario.
- Este equipo se puede utilizar por niños de 8 años o más y por personas con capacidades físicas, sensoriales o mentales reducidas, o bien por personas que carecen de experiencia o conocimientos adecuados, con tal de que se les supervise y hayan recibido instrucciones acerca del uso seguro del equipo y se les haya informado sobre los peligros potenciales.
- Cualquier cambio eléctrico o mecánico realizado en este armario anulará la garantía. Los cambios realizados por técnicos de servicio no autorizados y los cambios distintos a los descritos en este manual también anularán la garantía. El fabricante no aceptará ninguna responsabilidad por los daños derivados de dichos cambios.

CLASE CLIMÁTICA

El armario está diseñado para funcionar dentro de unos niveles específicos de temperatura ambiente y humedad. Estos se establecen en el sistema de clase climática. Estos niveles nunca deben superarse. La clase climática para este producto puede encontrarse en la etiqueta de descripción del mismo. El frigorífico no es apto para su uso a temperaturas inferiores a 16 °C de temperatura ambiente.

Clase climática	Temperaturas ambiente y humedad
4	+30 °C con un 55 % de HR
5	+40 °C con un 40 % de HR

PRIMERA RECEPCIÓN Y CONTROLES

Este armario se embaló con un material protector para su envío. En el momento de la entrega, compruebe que el armario no haya sufrido ningún daño durante el transporte y que el modelo sea el que usted encargó.



IMPORTANTE

Todas las operaciones indicadas a continuación deben cumplir íntegramente con todos los reglamentos locales y las normas de seguridad. Tenga en cuenta todas las normas de seguridad vigentes cuando utilice este producto.

TRANSPORTE

Si desea levantar el producto utilizando maquinaria, debe comprobar la capacidad de elevación de la misma antes de realizar cualquier procedimiento de este tipo.



IMPORTANTE

Si utiliza una carretilla elevadora para mover el producto, compruebe que las horquillas estén insertadas en las aberturas correspondientes del palé.

Una vez en movimiento, debe prestarse atención a la estabilidad del producto. Si el centro de gravedad no está centrado en el producto, aumentarán las posibilidades de que se caiga. Si baja el producto con una carretilla elevadora, realice la operación lentamente y con cuidado.

Si fuera necesario transportar los armarios verticales en posición horizontal, procure que hayan estado en posición vertical como mínimo durante 2 horas antes de activarlos. No es recomendable transportar los armarios verticales en posición horizontal; cualquier daño derivado de dicha acción no está cubierto por la garantía.

PREMIER UNDERCOUNTER



ATENCIÓN

Las recomendaciones indicadas en el exterior del embalaje de transporte son útiles para el usuario. Por lo tanto, deben observarse las siguientes recomendaciones:

- Transporte el producto con cuidado.
- Mantenga seco el producto. ¡No almacene productos en la parte superior del armario!

ABRIR EL EMBALAJE

- Retire el cartón y cualquier otro material de embalaje.
- Levante el armario para desencajarlo y retírelo del palé.
- Coloque el armario en el lugar deseado, sobre su propia base.
- Compruebe si hay daños visibles.
- Los materiales de embalaje pueden reciclarse de acuerdo con la normativa local.
- Compruebe que el código del producto y el número de serie coincidan con los indicados en los documentos de envío.

Marca comercial			HOSHIZAKI			
Nombre del modelo			PREMIER F 2 A DL DR	PREMIER K/M 2 A DL DR	PREMIER K/M 2 A 2D 2D	PREMIER K/M 2 A 3D 3D
Uso previsto			Storage	Storage	Storage	Storage
Temperatura operativa de				X	X	X
Temperatura operativa de			X			
Armario multiusos						
Armario vertical						
Armario en encimera			X	X	X	X
Parámetro	Symbol	Unit				
Clasificación Eficiencia Energética	EEC	-	C	A+	A	A
Índice de Eficiencia Energética	EEL	-	40,26	13,9	17,42	17,85
Consumo energético en 24 horas	E24h	kWh	3,862	0,869	1,069	1,069
Consumo energético anual	AEC	kWh	1410	317	390	390
Volumen neto del compartimento 1	Vn1	litre	96	96	88	77,5
Volumen neto del compartimento 2	Vn2	litre	96	96	88	77,5
Volumen neto del compartimento 3	Vn3	litre	-	-	-	-
Volumen neto del compartimento 4	Vn4	litre	-	-	-	-
Volumen neto total	VnT	litre	192	192	176	155
Clase climática	CC		5	5	5	5
Refrigerante			R290	R600a	R600a	R600a
Carga		kg	0.055	0.07	0.07	0.07
GWP			3	3	3	3
Equivalente de CO2		CO ₂	0,165	0,21	0,24	0,21
Uso industrial; este aparato está diseñado para utilizarse en una temperatura ambiente máxima de 40 °C			X	X	X	X
Datos de contacto:	HOSHIZAKI EUROPE B.V.					
	Address: Burgemeester Stramanweg 101 1101 AA Amsterdam, The Netherlands Tel.: +31 (0)20 691 84 99 - http://hoshizaki.europe.com/					

HOSHIZAKI

PREMIER UNDERCOUNTER



Marca comercial			HOSHIZAKI			
Nombre del modelo			PREMIER F 3 A DL DL DR	PREMIER K/M 3 A DL DL DR	PREMIER K/M 3 A 2D 2D 2D	PREMIER K/M 3 A 3D 3D 3D
Uso previsto			Storage	Storage	Storage	Storage
Temperatura operativa de				X	X	X
Temperatura operativa de			X			
Armario multiusos						
Armario vertical						
Armario en encimera			X	X	X	X
Parámetro	Symbol	Unit				
Clasificación Eficiencia Energética	EEC	-	C	A	A	A
Índice de Eficiencia Energética	EEL	-	47,98	18,77	21,29	22,02
Consumo energético en 24 horas	E24h	kWh	5,340	1,299	1.438	1.438
Consumo energético anual	AEC	kWh	1949	474	525	525
Volumen neto del compartimento 1	Vn1	litre	96	96	88	77,5
Volumen neto del compartimento 2	Vn2	litre	96	96	88	77,5
Volumen neto del compartimento 3	Vn3	litre	96	96	88	77,5
Volumen neto del compartimento 4	Vn4	litre	-	-	-	-
Volumen neto total	VnT	litre	288	288	264	232
Clase climática	CC		5	5	5	5
Refrigerante			R290	R290	R290	R290
Carga		kg	0.055	0.065	0.065	0.065
GWP			3	3	3	3
Equivalente de CO2		CO ₂	0,165	0,195	0,195	0,195
Uso industrial; este aparato está diseñado para utilizarse en una temperatura ambiente máxima de 40 °C			X	X	X	X
Datos de contacto:	HOSHIZAKI EUROPE B.V. Address: Burgemeester Stramanweg 101 1101 AA Amsterdam, The Netherlands Tel.: +31 (0)20 691 84 99 - http://hoshizaki.europe.com/					

HOSHIZAKI

PREMIER UNDERCOUNTER



Marca comercial			HOSHIZAKI			
Nombre del modelo			PREMIER F 4 A DL DL DR DR	PREMIER K/M 4 A DL DL DR DR	PREMIER K/M 4 A 2D 2D 2D 2D	PREMIER K/M 4 A 3D 3D 3D 3D
Uso previsto			Storage	Storage	Storage	Storage
Temperatura operativa de				X	X	X
Temperatura operativa de			X			
Armario multiusos						
Armario vertical						
Armario en encimera			X	X	X	X
Parámetro	Symbol	Unit				
Clasificación Eficiencia Energética	EEC	-	C	A	A	A
Índice de Eficiencia Energética	EEL	-	44,77	17,37	21,87	22,79
Consumo energético en 24 horas	E24h	kWh	5,67	1,319	1,612	1,612
Consumo energético anual	AEC	kWh	2070	481	588	588
Volumen neto del compartimento 1	Vn1	litre	96	96	88	77,5
Volumen neto del compartimento 2	Vn2	litre	96	96	88	77,5
Volumen neto del compartimento 3	Vn3	litre	96	96	88	77,5
Volumen neto del compartimento 4	Vn4	litre	96	96	88	77,5
Volumen neto total	VnT	litre	384	384	352	310
Clase climática	CC		4	5	4	4
Refrigerante			R290	R290	R290	R290
Carga		kg	0.055	0.065	0.065	0.065
GWP			3	3	3	3
Equivalente de CO2		CO ₂	0,165	0,195	0,195	0,195
Uso industrial; este aparato está diseñado para utilizarse en una temperatura ambiente máxima de 40 °C				X		
Datos de contacto:	HOSHIZAKI EUROPE B.V.					
	Address: Burgemeester Stramanweg 101 1101 AA Amsterdam, The Netherlands Tel.: +31 (0)20 691 84 99 - http://hoshizaki.europe.com/					

HOSHIZAKI

PREMIER UNDERCOUNTER



II. INSTRUCCIONES DE FUNCIONAMIENTO

ELECTRICIDAD

Antes de conectar el producto a la red, compruebe que la alimentación eléctrica especificada en la etiqueta de descripción del producto coincida con la de la red eléctrica local.

La etiqueta de descripción del producto con la alimentación eléctrica especificada se encuentra en el interior del armario, en la parte superior izquierda.

La instalación del producto debe realizarla únicamente personal de servicio calificado y con la formación adecuada, de acuerdo con las especificaciones indicadas en este manual.

La seguridad eléctrica de este armario solo puede garantizarse si está conectado a tierra de acuerdo con las leyes y reglamentos locales vigentes.

Siempre debe realizarse la puesta a tierra del producto.

El fabricante no aceptará ninguna responsabilidad por los daños derivados de una puesta a tierra incorrecta.

Cumpla con todos los requisitos eléctricos estipulados por la normativa eléctrica local. El conector eléctrico del producto y la toma de corriente deben tener las especificaciones correctas de conectividad a tierra. Si fuera necesario, contacte con un electricista cualificado.

COMPROBACIONES PRELIMINARES GENERALES

Compruebe que el armario se encuentre sobre una superficie plana y en posición vertical. Si fuera necesario, pueden utilizarse las patas ajustables del armario para nivelarlo. Todas las patas deben estar en contacto con el suelo. Esto es necesario para el correcto funcionamiento de la puerta del armario.

No coloque el armario junto a dispositivos que generen calor, como por ejemplo hornos, parrillas y freidoras. No lo exponga a la luz solar directa. El calor que pueden irradiar paredes o suelos debe aislarse con material aislante adecuado. El armario debería situarse lo más lejos posible de cualquier fuente de calor.

Si cambia el armario de lugar, espere tres horas antes de volverlo a activar. Debe retirarse la protección plástica o la cinta de las superficies exteriores.

Compruebe que el armario esté colocado de modo que pueda fluir suficiente aire fresco hacia/desde el circuito de refrigeración y alrededor de las superficies del armario. Deje como mínimo 500 mm de espacio libre en la parte superior del armario.

Si se van a colocar dos frigoríficos o congeladores uno al lado del otro, debe haber un espacio mínimo de 50 mm entre ellos.

No bloquee ningún orificio de ventilación.

COMPROBACIONES ELÉCTRICAS PRELIMINARES

- Compruebe que la tensión de la red y la frecuencia de la toma coincidan con la información de la etiqueta de descripción del producto.
- El armario se conecta a una toma de corriente con un fusible de 13-16 Amp como una conexión en serie.
- Desactive el fusible de red conectado al cable de alimentación.
- Compruebe que el conector del armario encaje correctamente en la toma de corriente que se va a utilizar.

PREMIER UNDERCOUNTER

PRIMERAS OPERACIONES Y CONTROLES

Una vez completadas las comprobaciones anteriores, ya se puede utilizar el armario. El armario se activa y desactiva con el interruptor de encendido/apagado.

El compresor empieza a funcionar una vez activado el armario. El compresor estará activo hasta que se alcance la temperatura preajustada de fábrica. No deberían colocarse alimentos en el armario hasta que se haya definido el ajuste de temperatura en función de los alimentos a enfriar.

Puede realizarse un nuevo ajuste de temperatura a través del controlador, de la forma indicada en este manual.



IMPORTANTE

- Deje que el producto se enfríe a la temperatura establecida antes de colocar alimentos en su interior.
- Nunca sobrepase la capacidad de carga máxima. La capacidad máxima de las estanterías es una carga uniforme de 40 kg cada una para los armarios verticales y de 20 kg para las estanterías y los cajones de los armarios en encimera.
- Consulte la sección “Comprobaciones preliminares generales” de este manual para más información acerca del espacio necesario para conseguir una buena circulación de aire alrededor del producto.
- No almacene sustancias explosivas, como por ejemplo aerosoles con propelente inflamable, en este aparato.
- En caso de cajón de 1/3, no se puede utilizar la tapa del contenedor con equipo de sellado.

ADVERTENCIA:

- No bloquee en ningún momento las aberturas de ventilación del aparato.
- No utilice dispositivos mecánicos, ni otros medios distintos a los recomendados por el fabricante, para acelerar el proceso de descongelación.
- No dañe el circuito de refrigerante.
- No utilice aparatos eléctricos dentro del armario.
- No dañe el cable de alimentación, el cableado ni ningún componente clave.

CONDICIONES DE ALMACENAMIENTO Y RENDIMIENTO

Unas condiciones de almacenamiento correctas no solo son esenciales para la seguridad e higiene de los alimentos, sino que mejoran la calidad del servicio y reducen el consumo energético. Para conseguir el mejor rendimiento posible, deben observarse los siguientes consejos y directrices: coloque todos los alimentos en las estanterías, nunca en el suelo del armario. Los alimentos deben colocarse en el armario o en la encimera de forma que permitan una buena circulación de aire, dejando espacio entre ellos y las paredes del producto. Si fuera necesario, puede ajustarse según convenga la distancia entre las estanterías.

PREMIER UNDERCOUNTER

III. PANEL DE CONTROL



➤ FUNCIONES DEL PANEL FRONTAL

Para bloquear las teclas de la tapa delantera, mantenga pulsado AUX (3) y On / Stand By (1) durante 2 segundos: si las teclas están bloqueadas se mostrará en pantalla el texto "Loc", mientras que si no lo están se mostrará el texto "UnL".

- 1) Si se mantiene pulsado **ON/STAND BY** durante 4 segundos, el dispositivo se abre o se cierra. (Encendido/Apagado)
- 2) **MANUAL DEFROST**; si se pulsa el botón durante 4 segundos, se inicia la descongelación manual. Si la refrigeración excesiva está activa y la temperatura del evaporador no es adecuada, no se iniciará la descongelación manual.
- 3) Tecla **DOWN**: permite desplazarse hacia abajo en el menú o reducir el valor; si se mantiene pulsada durante 4 segundos, se activa la superrefrigeración. Cuando la función de refrigeración excesiva está activa, la temperatura establecida se puede reducir; el tiempo y la temperatura se determinan con la ayuda de los parámetros. Cuando la función de refrigeración excesiva está activada, el dispositivo nunca descongela.
- 5) Tecla **UP**: permite desplazarse hacia arriba en el menú o aumentar el valor; si se mantiene pulsada durante 4 segundos, se activa la función de porcentaje de humedad relativa baja y alta. (Para algunos modelos) Se muestra "rhL" en la pantalla (la función de porcentaje bajo de humedad relativa está activa) o se muestra "rhH" en la pantalla (la función de porcentaje alto de humedad relativa está activa). Estas funciones aparecen en la pantalla durante 10 segundos. Si el control de humedad no está disponible, "----" se muestra en la pantalla durante 1 segundo.
- 6) Tecla **SET**: tecla para introducir y cambiar los valores ajustables.

➤ FUNCIONAMIENTO

A continuación se indican los casos de funcionamiento disponibles:

Estado "On": (El dispositivo está activado y funciona).

Estado "Stand-By": (El dispositivo está apagado, pero aún está conectado).

Estado "Of": Para apagar el dispositivo, retire el enchufe de la toma o desconecte el fusible principal.

PREMIER UNDERCOUNTER

IV. INSTRUCCIONES DE MANTENIMIENTO

El dispositivo debe limpiarse periódicamente. Los intervalos dependen del uso y del grado de suciedad (como mínimo una vez al año).



Antes de realizar operaciones de limpieza o de mantenimiento, desenchufe la unidad



No toque ni humedezca las piezas del compartimento de la máquina. Podría provocar fallos o estropear la máquina.



Para evitar posibles daños, no limpie las piezas de plástico con agua a una temperatura superior a 40 °C o en un lavavajillas.

Interior y exterior del armario y las estanterías



Para usos sanitarios, limpie el interior y el exterior al menos una vez a la semana.



Empape un paño suave en agua caliente o fría que contenga una cantidad adecuada de detergente neutro, escúrralo y limpie el interior y el exterior del armario. No use un chorro de agua para limpiar el compartimento de la máquina.



Otros productos químicos que no sean un detergente neutro pueden causar daños en las superficies interiores y exteriores.



Los restos de detergente dañan las superficies de metal o de plástico. Utilice un trapo suave, mojado en agua tibia, para limpiarlos.



No utilice los siguientes productos, podrían dañar las superficies pintadas o de plástico:

- Pulimento en polvo, alcohol, disolvente, benceno, detergente ácido o alcalino, agua caliente, petróleo, jabón en polvo, estropajo o cepillos de metal, etc. Concretamente, no utilice detergente para limpiar la grasa del ventilador o del microondas

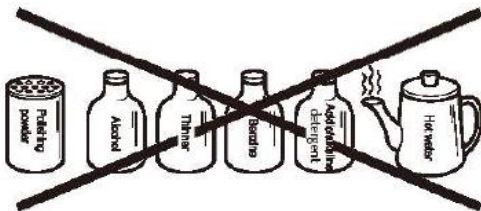

Nota: otros compuestos distintos a los anteriores también podrían dañar las superficies pintadas o de plástico. ¡Deje de usar dichos compuestos de inmediato si causan problemas!



La junta hermética de la puerta y su superficie de contacto se ensucian con facilidad. Limpie cuidadosamente las superficies de estas piezas. Los restos de alimentos acelerarán el proceso de envejecimiento.



Use un paño para retirar el agua que pueda quedar en el interior.

PREMIER UNDERCOUNTER

Condensador



Utilice una aspiradora o un cepillo suave para eliminar el polvo y las manchas del condensador.



Advertencia: **si el usuario limpia el condensador con un cepillo duro, como por ejemplo un cepillo para lavavajillas, puede desprenderse el revestimiento del condensador.**

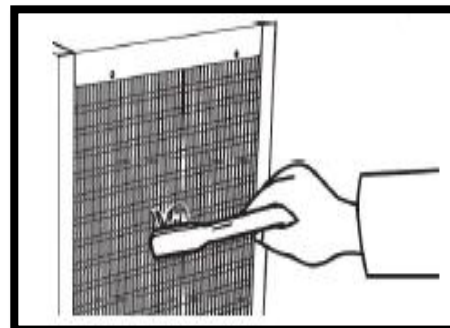

Filtro de aire



Para evitar que se deforme, no lave el filtro de aire con agua caliente a más de 40 °C



Los filtros de aire con malla de plástico eliminan la suciedad o el polvo del aire y evitan que el condensador se obstruya. Si el filtro se obstruye, el rendimiento del frigorífico/congelador se reduce.



Compruebe los filtros al menos dos veces al mes. Cuando esté obstruido o cuando el controlador de temperatura muestre "cH", utilice agua tibia y un detergente neutro para lavar los filtros. No haga funcionar la unidad sin los filtros de aire porque el condensador se obstruirá y se producirán averías.

- 1) Abra la tapa delantera y extraiga el filtro de aire. Para evitar daños, no toque las aletas del condensador directamente.
- 2) Limpie cuidadosamente el filtro de aire con agua fría o caliente que contenga una cantidad adecuada de detergente neutro. Aclare y seque el filtro de aire cuidadosamente.
- 3) Para volver a colocar el filtro de aire, coloque las dos lengüetas en el intercambiador de calor o las aletas en el condensador y coloque firmemente el filtro de aire sobre el condensador.



HOSHIZAKI

PREMIER UNDERCOUNTER

V. INFORMACIÓN TÉCNICA

DIMENSIONES DE LOS DISPOSITIVOS

PREMIER K-M-F 2 A DL DR L

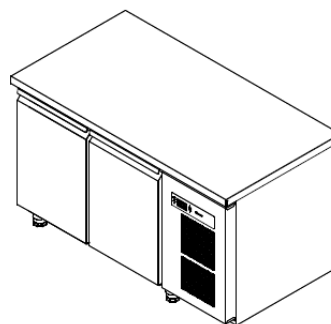
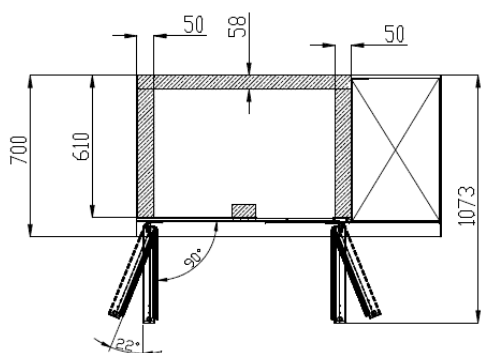
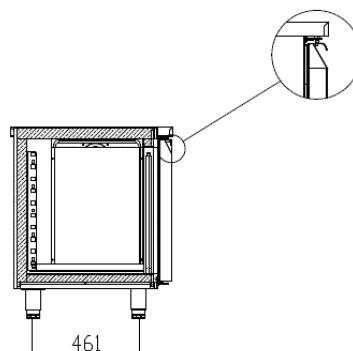
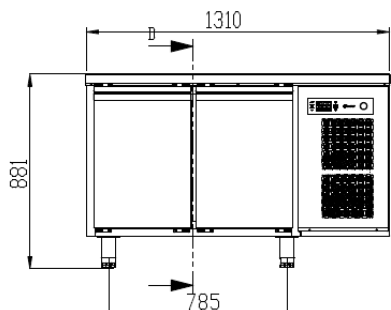

PREMIER K-M-F 2 A DL DR C

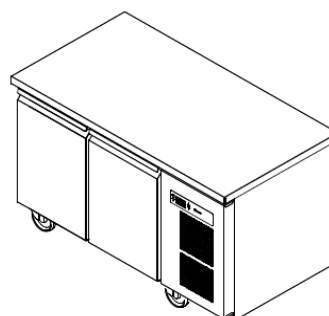
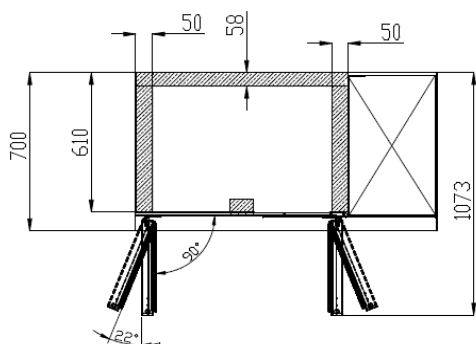
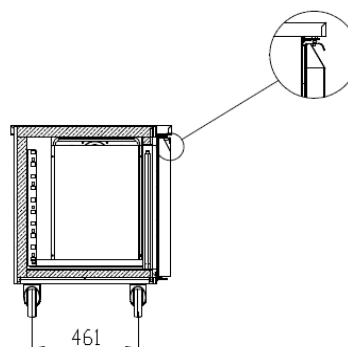
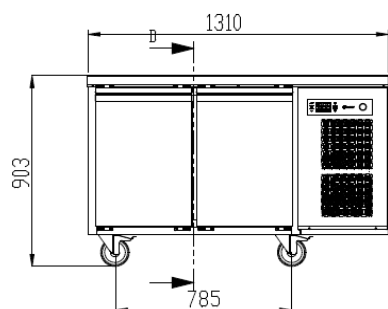

HOSHIZAKI

PREMIER UNDERCOUNTER



PREMIER K-M 2 A 2D 2D L

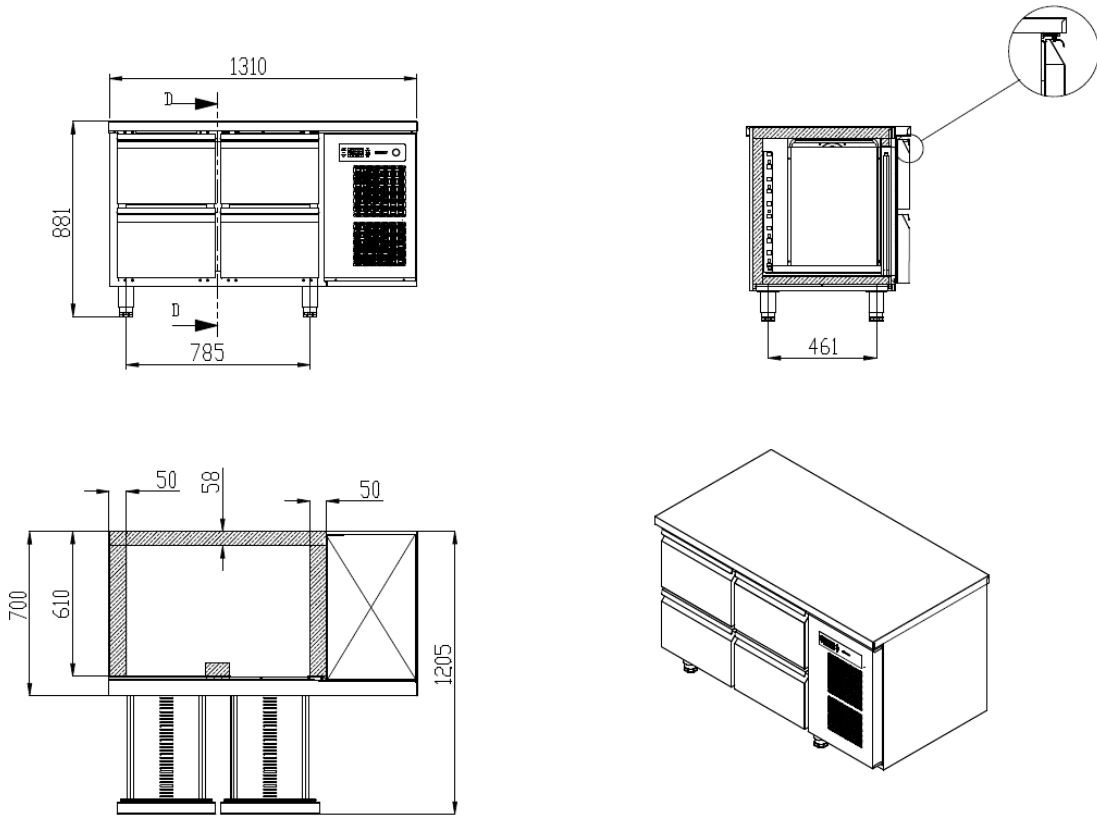

PREMIER K-M 2 A 2D 2D C

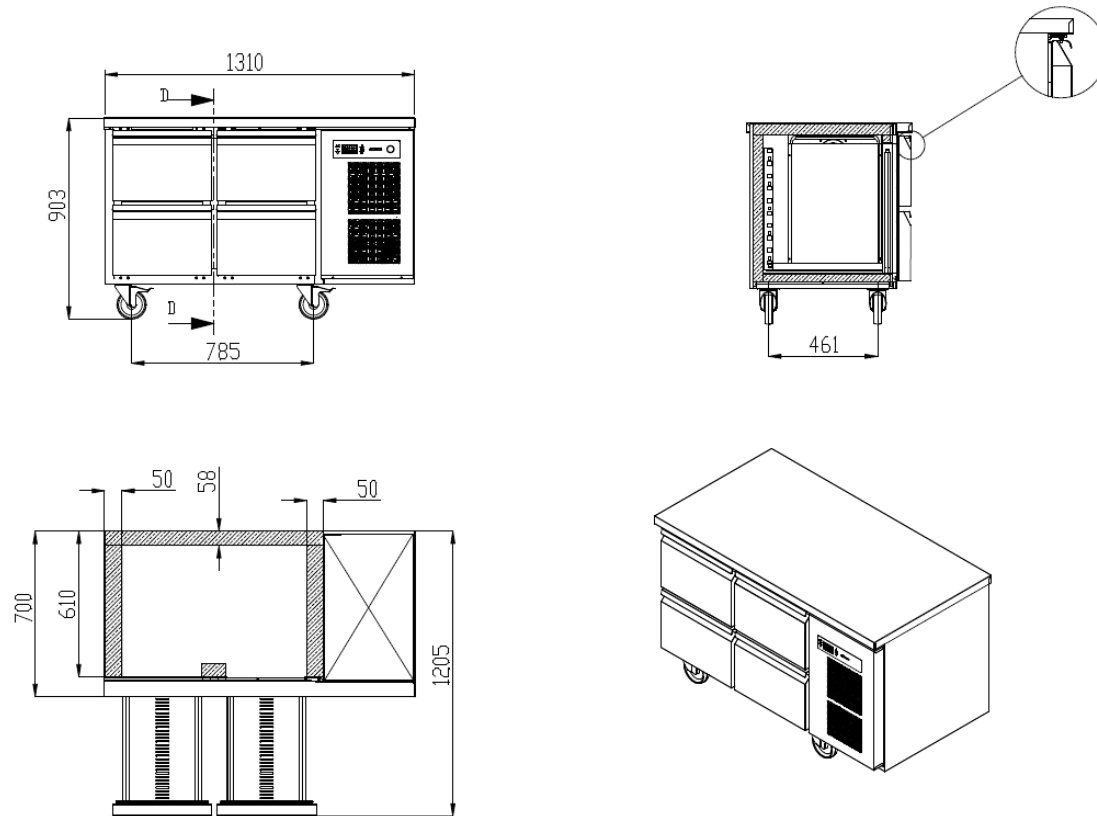

HOSHIZAKI

PREMIER UNDERCOUNTER



PREMIER K-M 2 A 3D 3D L

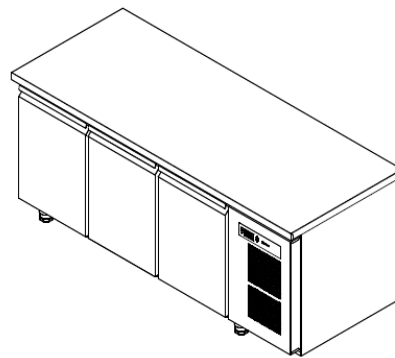
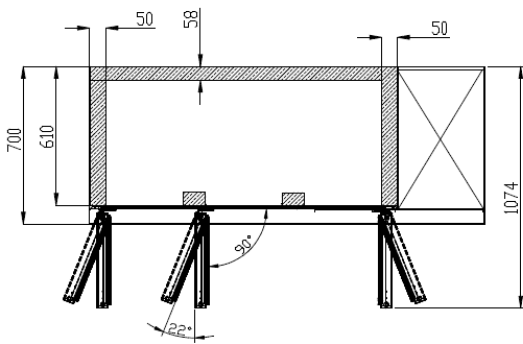
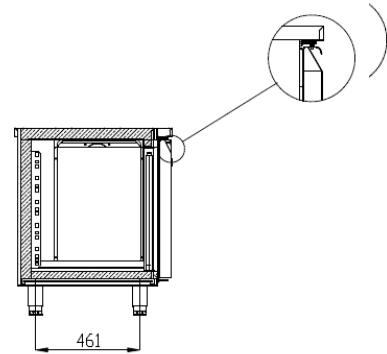
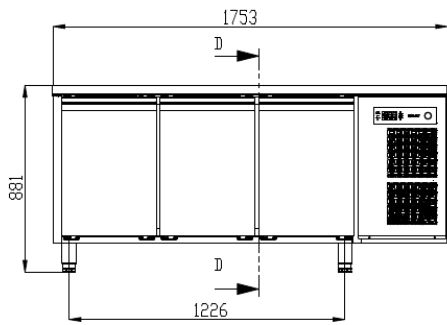

PREMIER K-M 2 A 3D 3D C

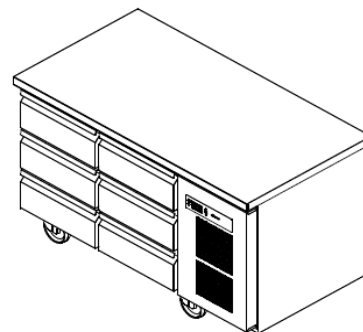
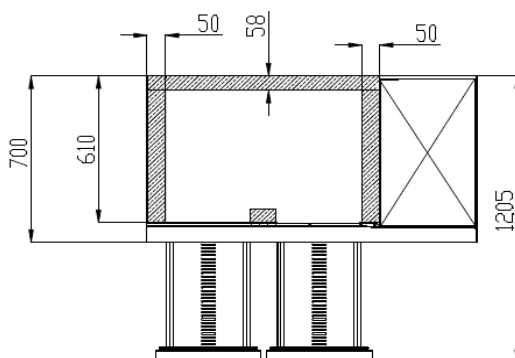
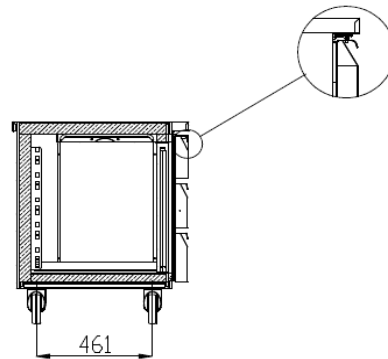
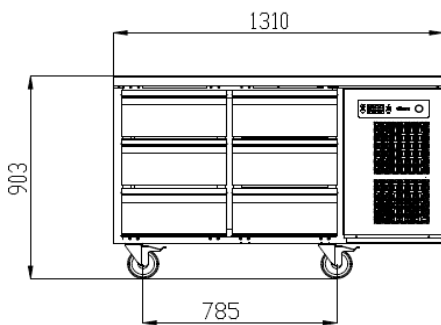

HOSHIZAKI

PREMIER UNDERCOUNTER



PREMIER K-M-F 3 A DL DR DR L

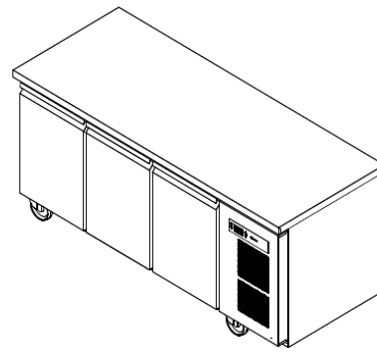
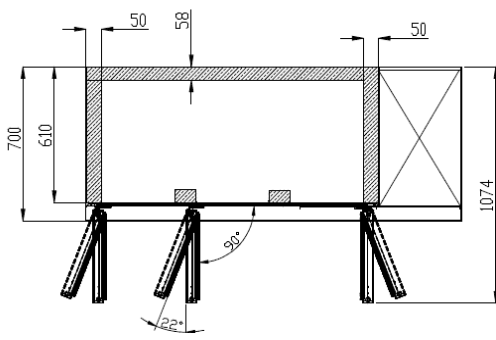
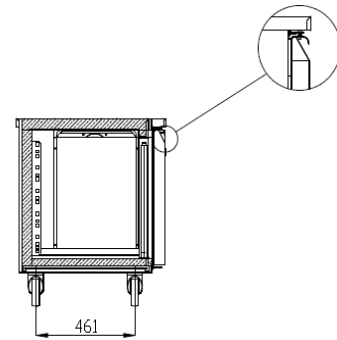
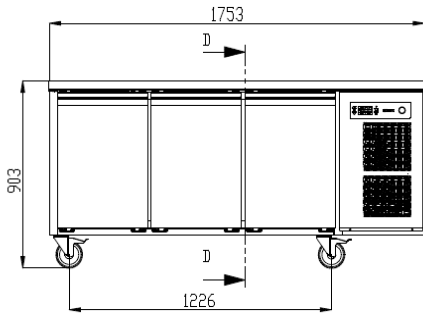

PREMIER K-M-F 3 A DL DR DR C

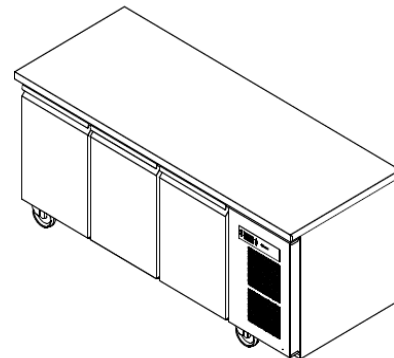
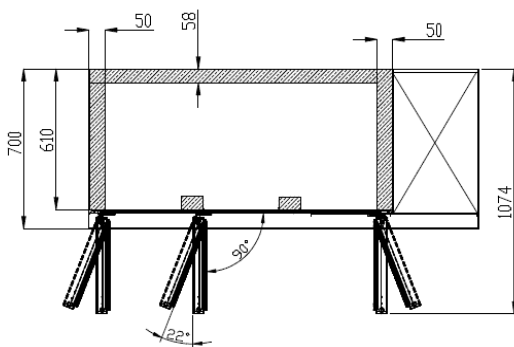
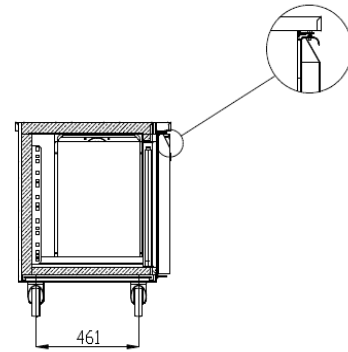
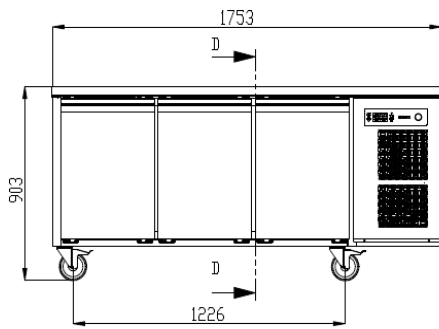

HOSHIZAKI

PREMIER UNDERCOUNTER



PREMIER K-M 3 A 2D 2D 2D L

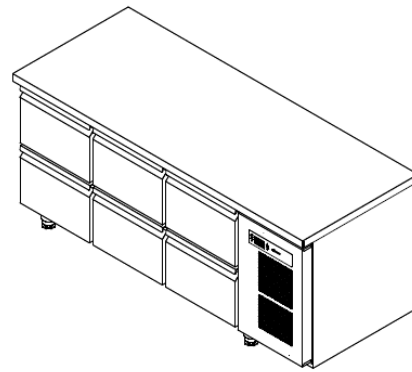
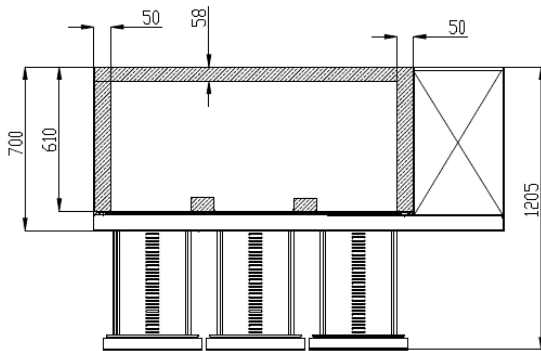
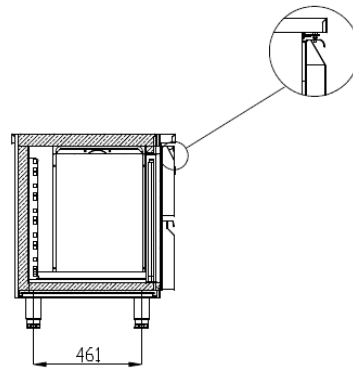
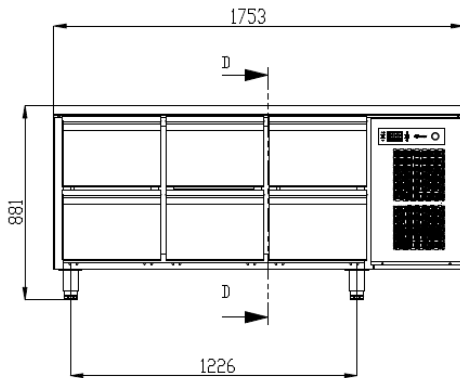

PREMIER K-M 3 A 2D 2D 2D C

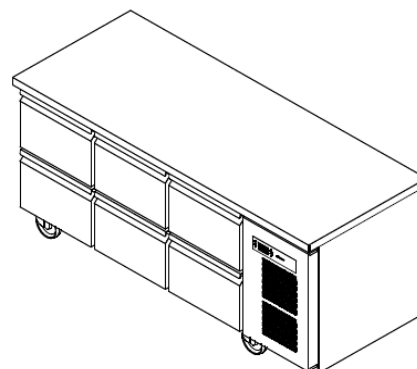
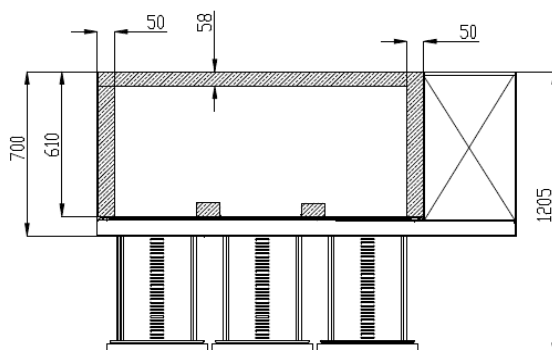
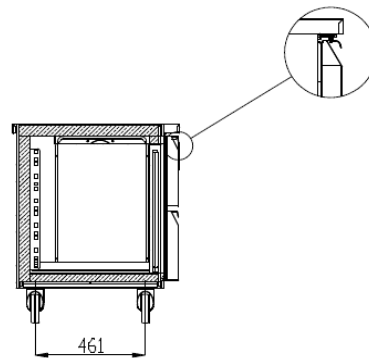
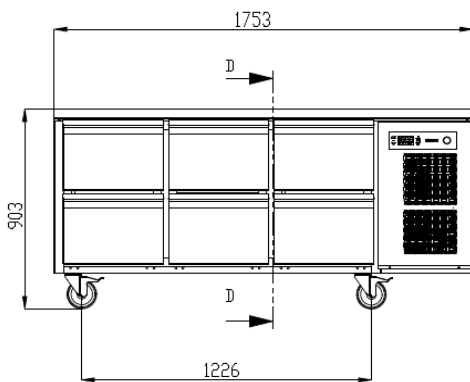

HOSHIZAKI

PREMIER UNDERCOUNTER



PREMIER K-M 3 A 3D 3D 3D 3 L

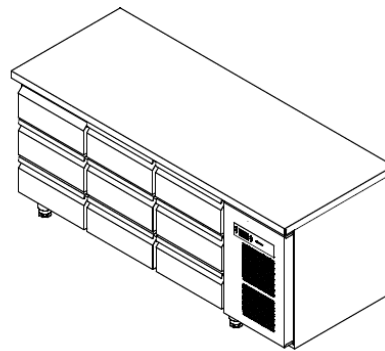
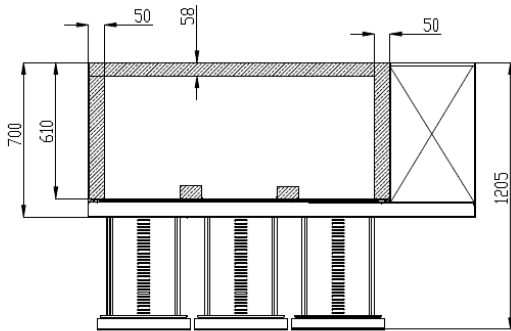
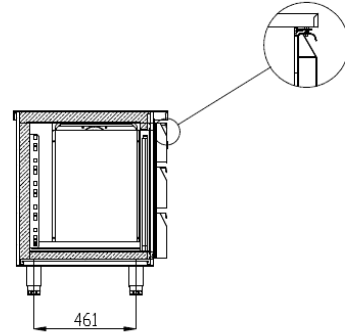
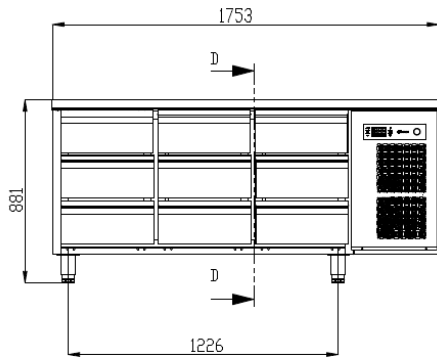

PREMIER K-M 3 A 3D 3D 3D 3 C

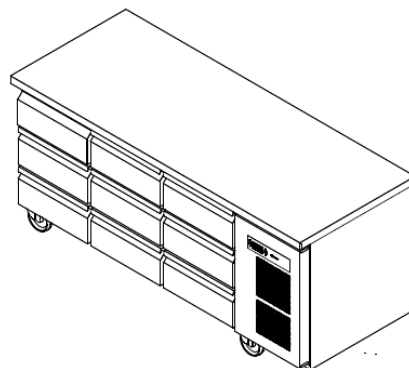
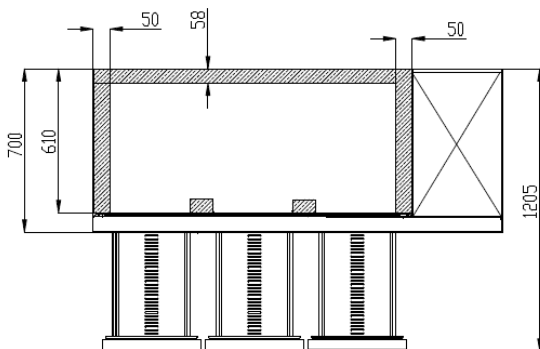
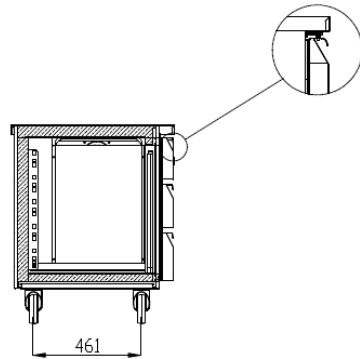
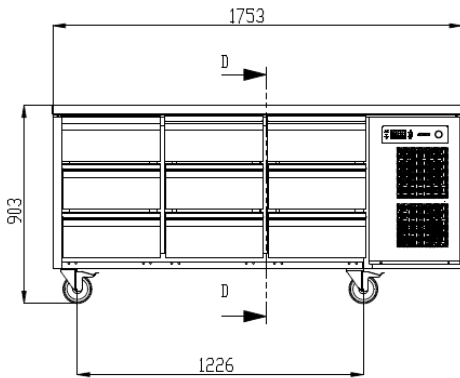

HOSHIZAKI

PREMIER UNDERCOUNTER



PREMIER K-M-F 4 A DL DL DR DR L

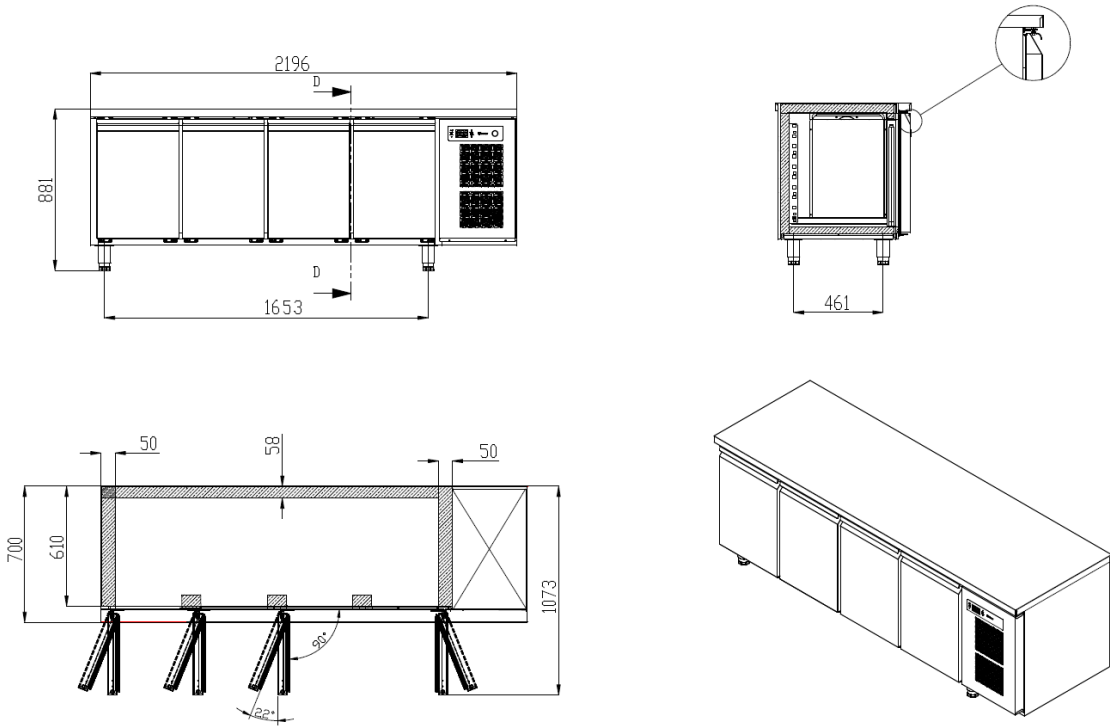

PREMIER K-M-F 4 A DL DL DR DR C

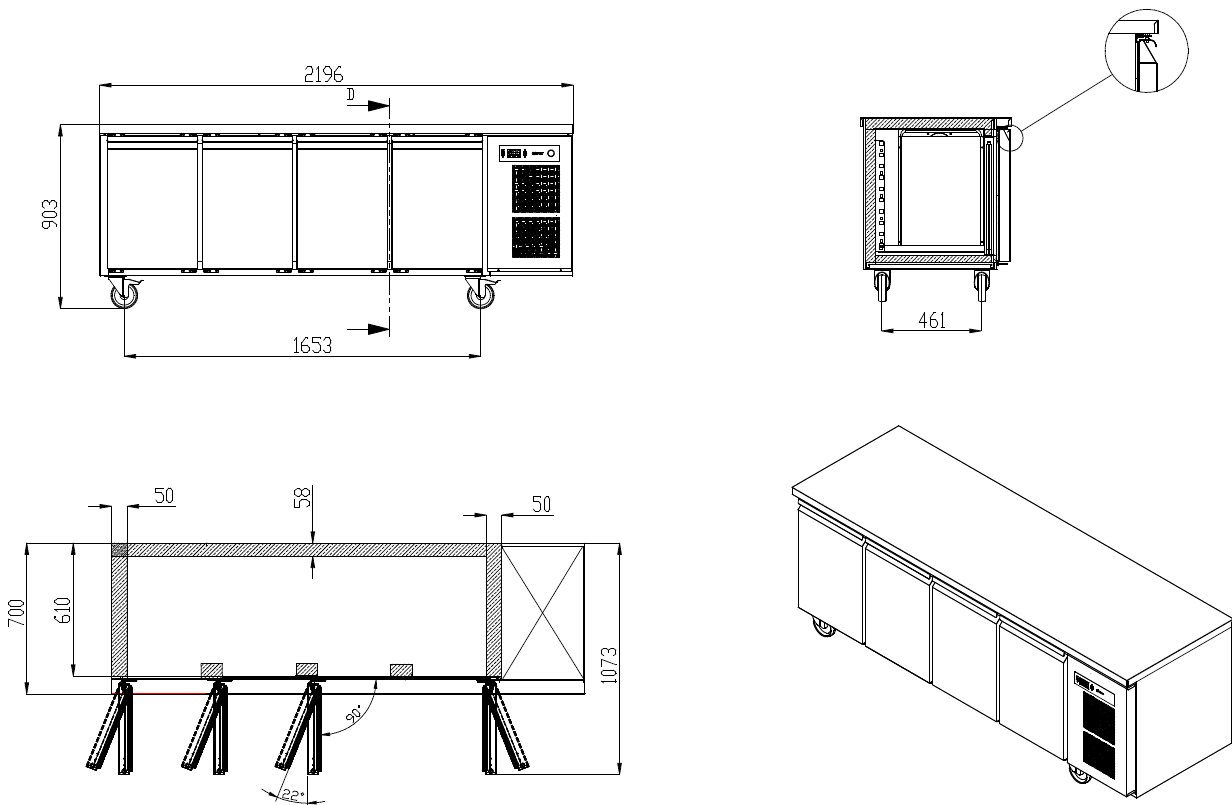

HOSHIZAKI

PREMIER UNDERCOUNTER



PREMIER K-M 4 A 2D 2D 2D 2D L

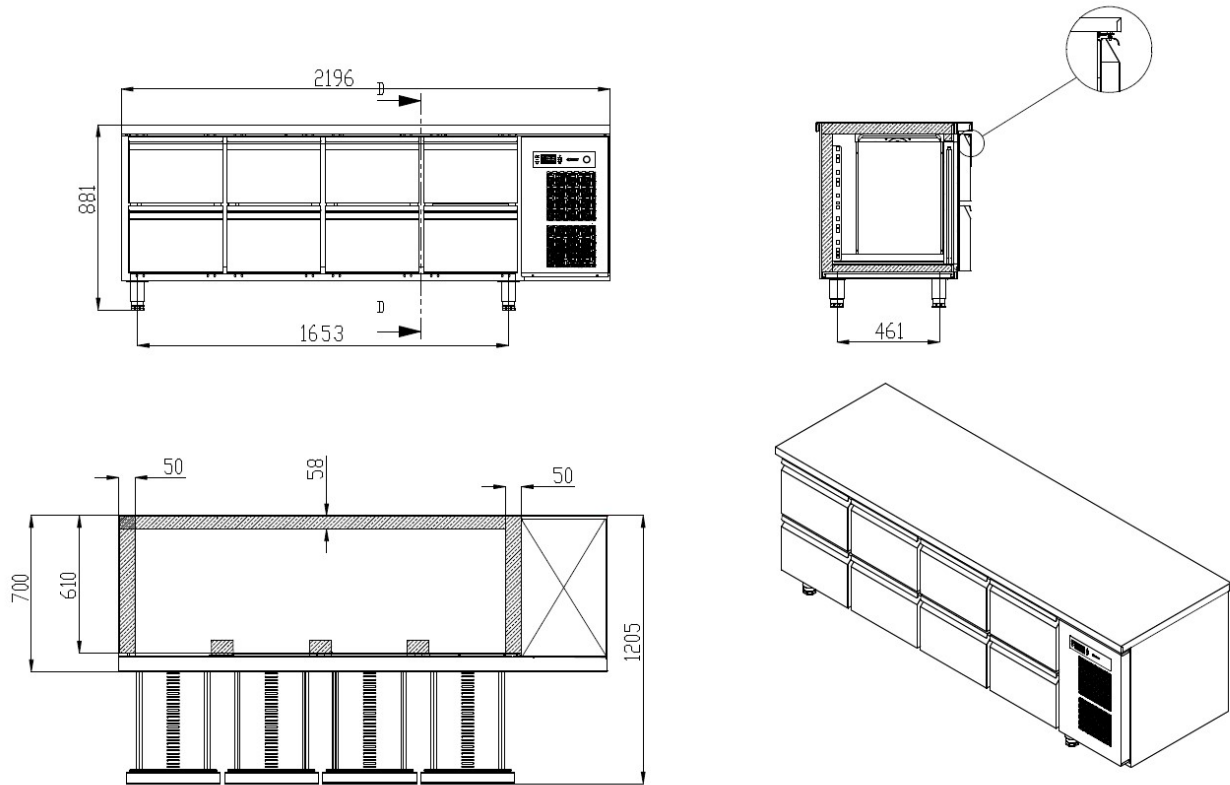

PREMIER K-M 4 A 2D 2D 2D 2D C

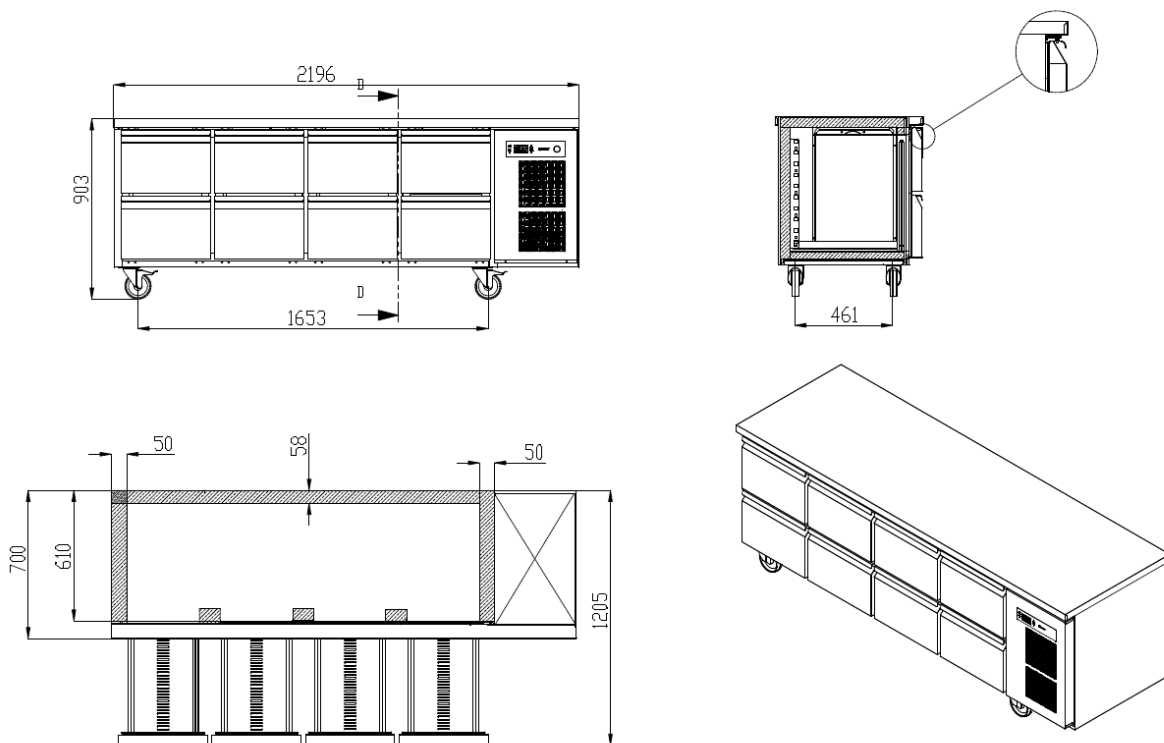

HOSHIZAKI

PREMIER UNDERCOUNTER



PREMIER K-M 4 A 3D 3D 3D 3D L

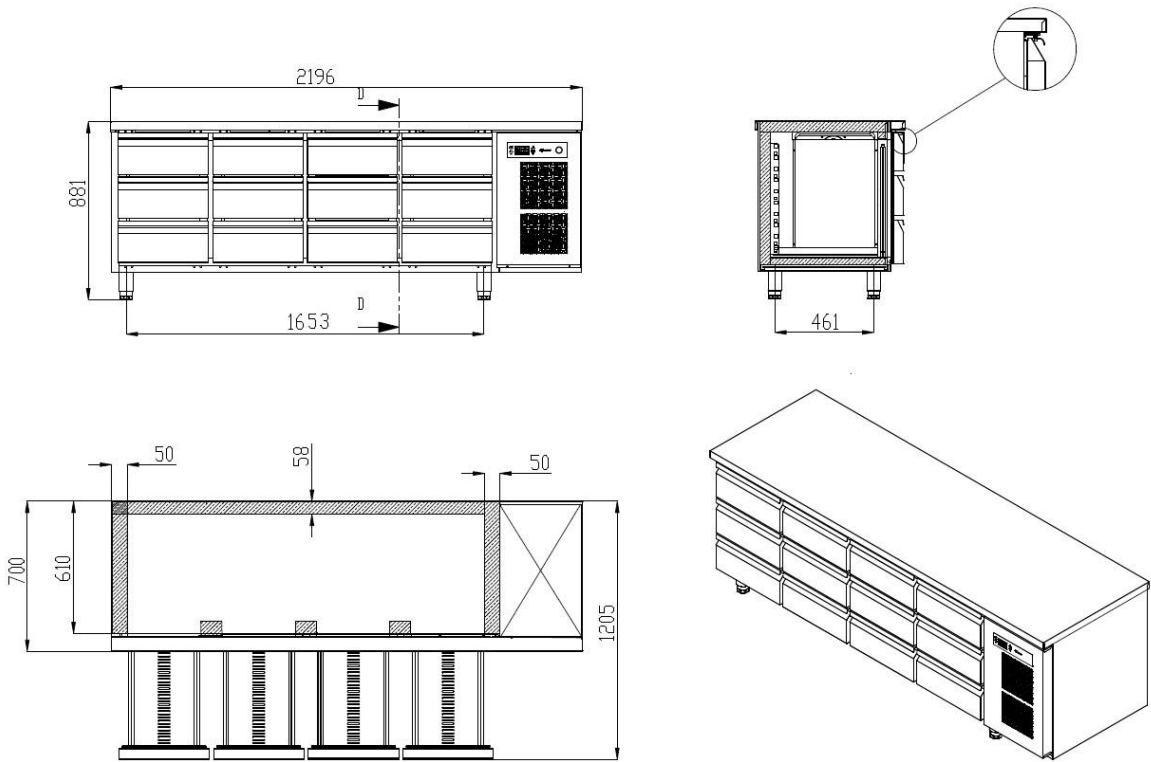

PREMIER K-M 4 A 3D 3D 3D 3D C

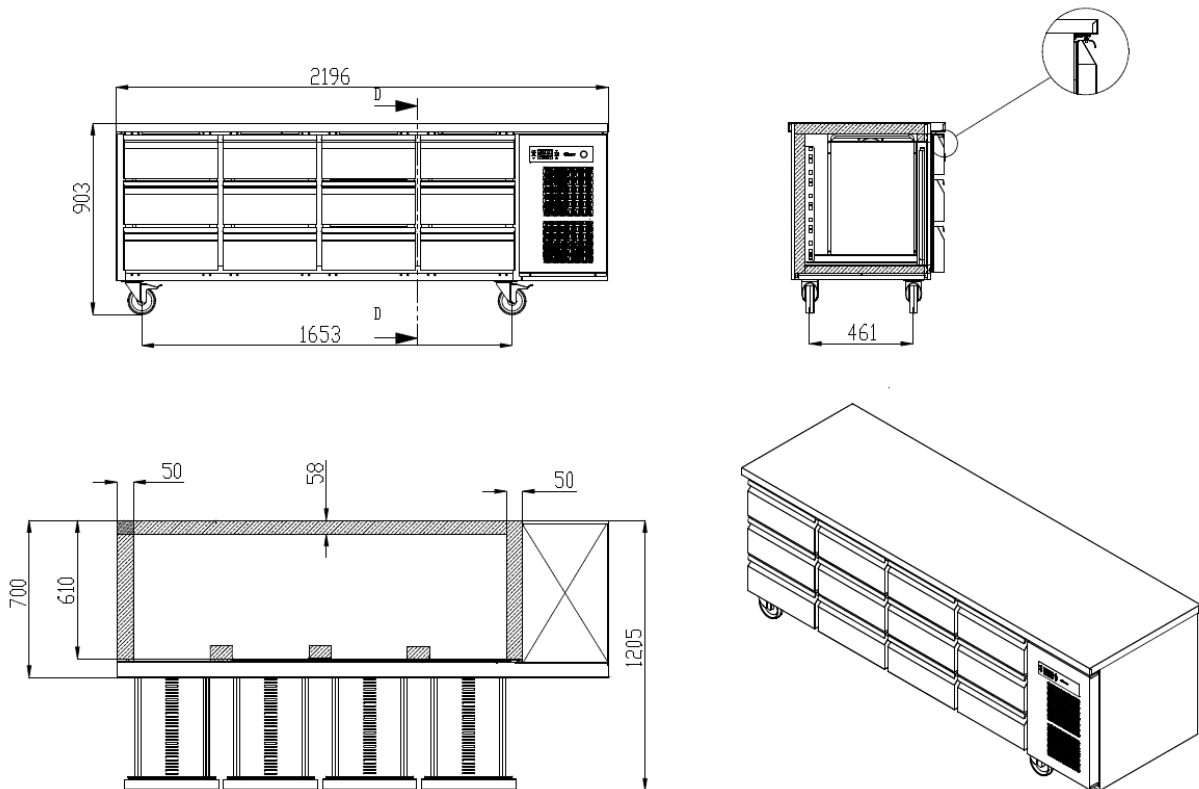

PREMIER UNDERCOUNTER

VI. DIAGRAMA DE REFRIGERACIÓN - ESQUEMA ELÉCTRICO

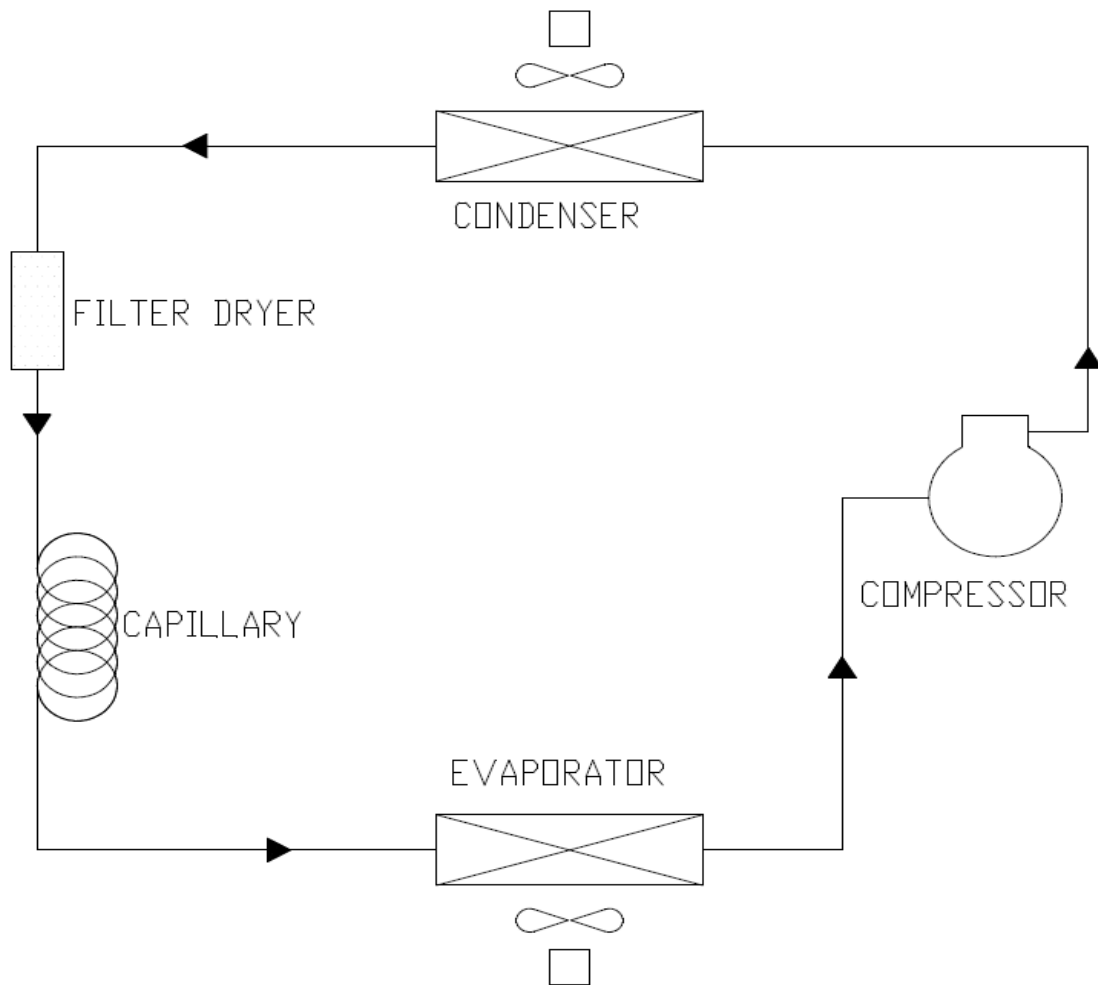



HOSHIZAKI

PREMIER UNDERCOUNTER

ESQUEMA ELÉCTRICO

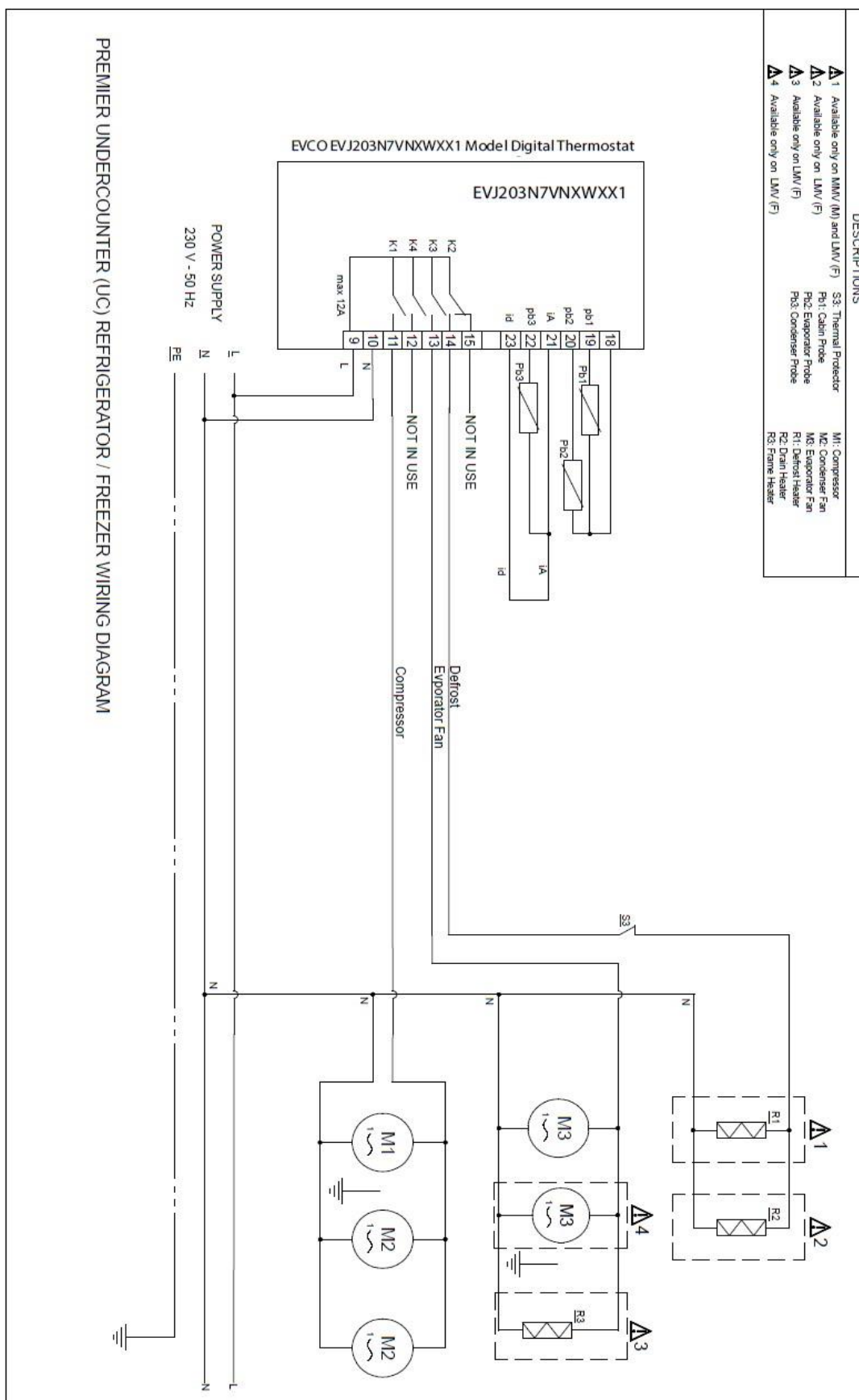

PREMIER UNDERCOUNTER

VII. DIAGNÓSTICO DE MANTENIMIENTO Y REPARACIÓN

En la siguiente tabla se muestran varios problemas con los que puede encontrarse. Si se muestra un código de alarma, se ha producido un fallo de funcionamiento. Corrija las posibles causas antes de reiniciar el armario. A continuación se enumeran las posibles causas y remedios.

Si el código de error sigue apareciendo después de realizar las siguientes comprobaciones, póngase en contacto con un técnico autorizado. Deben determinarse las características del mensaje de error. Los detalles del producto, incluido el número de serie, se encuentran en la placa de identificación del producto.

PROBLEMA	CAUSA POSIBLE	REMEDIO	
El armario no funciona	El armario no recibe alimentación eléctrica	Compruebe posibles defectos en el enchufe y el cable de alimentación	
El compresor no se detiene casi nunca	La temperatura ambiente es demasiado alta	Debe mejorarse la ventilación	
	El condensador o su filtro están bloqueados	Revise y limpie a menudo el filtro del condensador	
	Las juntas de las puertas no sellan correctamente	Contacte con un técnico autorizado para sustituir los sellos	
	El evaporador está congelado		No coloque alimentos calientes en el armario
			No coloque alimentos con un elevado contenido de agua dentro del armario, a menos que sea dentro de recipientes herméticos
	Empiece un ciclo de descongelación manual		
	El/los ventilador/es del evaporador son defectuosos	Contacte con un técnico autorizado para sustituir el/los ventilador/es	
El agua de la bandeja del condensador se derrama	Se colocan a menudo alimentos calientes en el armario	No coloque alimentos calientes en el armario	
		Los alimentos con un elevado contenido de agua solo deben colocarse en el armario dentro de recipientes herméticos	
	Se abren con frecuencia la puerta o los cajones	Compruebe si las especificaciones del armario son las más adecuadas para el uso que se le da actualmente	
La temperatura del armario es elevada	El condensador está obstruido por la suciedad y el polvo	Revise y limpie a menudo el filtro del condensador	
	La circulación de aire dentro del armario está obstruida	Retire los alimentos que impiden la circulación de aire	
	Penetra aire en el armario	Asegúrese de que la puerta esté cerrada	
		Compruebe posibles daños en las juntas de la puerta y del cajón	
	Empiece un ciclo de descongelación manual		

PREMIER UNDERCOUNTER

VIII. DESMONTAJE Y SUSTITUCIÓN

DESECHAR EL ARMARIO

- El gas de refrigeración utilizado en el armario se indica en la placa de identificación.
- El armario se ha fabricado con materiales reciclables, de acuerdo con la normativa de la UE. Por lo tanto, al final de su vida útil, el armario debe trasladarse al correspondiente centro de reciclaje para proceder a su eliminación.
- No recicle el armario como si fueran residuos metálicos o desechos domésticos.
- No comprima el circuito de refrigeración de la planta.



IMPORTANTE

Siga los reglamentos y normativas locales para la eliminación del armario.



PREMIER UNDERCOUNTER

Todos los derechos reservados. Hoshizaki se reserva el derecho a cambiar cualquier característica e información de este manual.

Datos de contacto

Oficina central

Hoshizaki Europe B.V – All other countries in Europe and Africa

TEL: +31 (0)20 6918499

sales@hoshizaki.nl -- <http://hoshizaki-europe.com/>

Sucursales

Hoshizaki UK - UK, Ireland

TEL: +44 (0)845 456 05 85

uksales@hoshizaki.co.uk

Hoshizaki Deutschland - Germany, Switzerland, Austria

TEL: +49 (0)5121 697370

vertrieb@hoshizaki.de

Hoshizaki Benelux - Netherlands, Belgium, Luxembourg

TEL: +31 (0)85 0188370

info@hoshizaki.nl

Hoshizaki France - France

TEL: +33 (0)1 48 63 93 80

info@hoshizaki.fr

Hoshizaki Iberia - Spain, Portugal

TEL: +34 (0)93 478 09 52

info@hoshizaki.es

Hoshizaki Denmark - Denmark

TEL: +45 89 88 53 50

salg@hoshizaki.dk

Hoshizaki Norway - Norge

TEL: +47 22 88 17 50

salg@hoshizaki.no

Hoshizaki Sweden - Sverige

TEL: +46 108 84 87 47

OrderSE@hoshizaki.dk

Hoshizaki Italia – Italia

TEL: +39 348 3022156

commerciale@hoshizaki.it

HOSHIZAKI

PREMIER UNDERCOUNTER



PREMIER UNDERCOUNTER

KOELKASTEN EN DIEPVRIEZERS HANDLEIDING VOOR BEDIENING, ONDERHOUD EN INSTALLATIE



I. ALGEMENE INFORMATIE	106
II. BEDIENINGSINSTRUCTIES	111
III. BEDIENINGSPANEEL	113
IV. AANWIJZINGEN VOOR ONDERHOUD	114
V. TECHNISCHE INFORMATIE	116
VI. KOELSCHEMA – BEDRADINGSSCHEMA	125
VII. OPSPOREN EN VERHELPEN VAN STORINGEN	127
VIII. VERWIJDEREN EN VERVANGEN	128

Contactinformatie:

HOSHIZAKI EUROPE B.V.

Adres: Burgemeester Stramanweg 101 1101 AA Amsterdam, Nederland

Tel: +31 (0)20 691 8499 <http://hoshizaki-europe.com/>



PREMIER UNDERCOUNTER

I. ALGEMENE INFORMATIE

LABEL MET PRODUCTBESCHRIJVING

1 - Productnummer
2 - Productbeschrijving
3 - Model
4 - Koelmiddel (GWP)
5 - CO ₂ -equivalent
6 - IP-bescherming
7 - Klimaatklasse
8 - Productiedatum
9 - Totaal vermogen / Stroom / Lampvermogen
10 - Spanning – Frequentie
11 - Verwarmingselement
12 - Systeemdruk
13 - Blaasmiddel
14 - Serienummer

PRODUCT NUMBER	1
	
PRODUCT DESCRIPTION	2
MODEL	3
REFRIGERANT	4
CO ₂ EQUIVALENT	5
IP PROTECTION	6
CLIMATE CLASS	7
PRODUCTION DATE	8
TOTAL POWER / CURRENT / LAMP POWER	9
VOLTAGE - FREQUENCY	10
HEATING ELEMENT	11
SYSTEM PRESSURE	12
BLOWING AGENT	13

S/N: 14



HOSHIZAKI EUROPE B.V. Burgemeester Stramanweg 101 1101 AA
Amsterdam, The Netherlands



GEBRUIKSTOEPASSING

- Dit product is alleen geschikt voor binnengebruik en uitsluitend voor het bewaren van voedsel en dranken. Compartimenten zijn bedoeld om producten op koelkast-/vriesertemperatuur te houden.
- De fabrikant is niet verantwoordelijk voor enige schade die voortvloeit uit gebruik in strijd met de vermelde richtlijnen in dit document.
- Bij het bewaren van voedsel in deze kast moet u ervoor zorgen dat voedsel nooit in contact komt met de behuizing van deze kast.
- Alle voedingswaren moeten volledig zijn afgedekt. Om vervuiling of corrosie van interne onderdelen te voorkomen, moeten alle producten in folie worden verpakt of in afgesloten bakjes worden bewaard.
- Bewaar geen hete voedingswaren of vloeistoffen in deze kast.
- Dranken in dozen of glazen flessen moeten niet worden bewaard bij een temperatuur onder 0 °C (vriespunt). Blikjes en glazen flessen kunnen barsten vanwege expansie. Bakjes met een deksel moeten niet volledig worden gevuld: zorg voor een kleine ruimte voor expansie.
- Deze kast is voorzien van een automatische zelfontdooiingsfunctie. Het is ook mogelijk om handmatig te ontdooien. Handmatig ontdooien vindt plaats via de controller en de kast hoeft hiervoor niet lange tijd te worden uitgeschakeld. In geen geval mag kracht of handgereedschap worden gebruikt om deze kast ijsvrij te maken; enige schade die voortvloeit uit dergelijke handelingen is moeilijk te repareren.
- Voer geen mechanische of alternatieve methoden van ontdooiing uit.
- Dit apparaat mag niet worden gebruikt door personen (inclusief kinderen) met verminderde fysieke, zintuiglijke of geestelijke capaciteiten, of een gebrek aan ervaring en kennis, tenzij dit gebeurt onder toezicht of na het verkrijgen van instructies.
- Het is kinderen niet toegestaan met het apparaat te spelen.

PREMIER UNDERCOUNTER

- Reiniging en gebruikersonderhoud mag niet zonder toezicht door kinderen worden uitgevoerd.
- Dit apparaat mag worden gebruikt door kinderen ouder dan 8 jaar of personen met verminderde fysieke, zintuiglijke of geestelijke capaciteiten, of een gebrek aan ervaring en kennis, mits dit gebeurt onder toezicht of na het verkrijgen van instructies met betrekking tot het veilige gebruik van het apparaat en de persoon begrijpt welke gevaren aan het gebruik zijn verbonden.
- Bij enige elektrische of mechanische wijzigingen aan deze kast vervalt de garantie. Bij wijzigingen die worden aangebracht door niet-geautoriseerde servicemonteurs en andere wijzigingen dan in deze handleiding worden beschreven, vervalt de garantie eveneens. De fabrikant aanvaardt geen enkele verantwoordelijkheid voor schade die voortvloeit uit dergelijke wijzigingen.

KLIMAATKLASSE

De kast is ontworpen voor gebruik binnen specifieke omgevingstemperaturen en vochtigheidsniveaus. Deze worden beschreven in het klimaatclassificatiesysteem. Deze niveaus mogen nooit worden overschreden. U vindt de klimaatklasse voor dit product op het label met de productbeschrijving. De koelkast is niet geschikt voor gebruik bij een omgevingstemperatuur die lager is dan 16 °C.

Klimaatklasse	Omgevingstemperaturen en vochtigheid
4	+30 °C met 55% RV
5	+40 °C met 40% RV

EERSTE ACCEPTATIE EN CONTROLES

Deze kast is verpakt in beschermend verpakkingsmateriaal voor verzending. Controleer bij levering de kast op mogelijke transportschade en of het kastmodel het model is dat u hebt besteld.



BELANGRIJK

Alle hieronder vermelde bewerkingen moeten volledig voldoen aan alle lokale statuten en veiligheidsvoorschriften. Neem alle geldende veiligheidsregels in acht bij bediening van dit product.

TRANSPORT

Bij het opheffen van het product met een werktuig moet de hefcapaciteit van het werktuig worden gecontroleerd voordat een dergelijke handeling wordt uitgevoerd.



BELANGRIJK

Wanneer een vorkheftruck wordt gebruikt om het product te verplaatsen, moet u zorgen dat de vorken in de juiste openingen in de pallet worden gestoken.

Tijdens het verplaatsen moet de stabiliteit van het product goed in de gaten worden gehouden. Als het zwaartepunt niet in het midden van het product ligt, is dit geneigd om te kantelen. Bij gebruik van een vorkheftruck moet u het product langzaam en voorzichtig laten zakken.

Als het nodig is om een rechtopstaande kast in een horizontale positie te vervoeren, moet u zorgen dat de kast minstens 2 uur rechtop heeft gestaan voordat deze wordt gebruikt. Het wordt niet aanbevolen rechtopstaande kasten in een horizontale positie te vervoeren en enige schade die voortvloeit uit een dergelijke handeling, valt niet onder de garantie.

PREMIER UNDERCOUNTER



LET OP

Aanbevelingen die aan de buitenkant van de transportverpakking zijn geschreven, zijn ten voordele van de gebruiker. Neem de volgende richtlijnen in acht:

- Draag het product voorzichtig.
- Houd het product droog. Leg niets bovenop de kast!

DE VERPAKKING OPENEN

- Verwijder het karton en al het andere verpakkingsmateriaal.
- Til de kast op om deze los te maken van de pallet.
- Plaats de kast op de gewenste locatie op de eigen standaard.
- Controleer op zichtbare schade.
- U kunt verpakkingsmateriaal recycelen volgens plaatselijke regelgeving voor recycling.
- Controleer of de productcode en het serienummer overeenkomen met die op de transportdocumenten.
 - Verify that the product code and serial number match the same on any shipping documents.

Handelsmerk			HOSHIZAKI			
Modelnaam			PREMIER F 2 A DL DR	PREMIER K/M 2 A DL DR	PREMIER K/M 2 A 2D 2D	PREMIER K/M 2 A 3D 3D
Bedoeld gebruik			Storage	Storage	Storage	Storage
Gekoelde bedrijfstemperatuur				X	X	X
Bevroren bedrijfstemperatuur			X			
Multifunctionele kast						
Verticale kast						
Werkbank			X	X	X	X
Parameter	Symbol	Unit				
Energie-efficiëntieklasse	EEC	-	C	A+	A	A
Energie-efficiëntie-index	EEL	-	40,26	13,9	17,42	17,85
Energieverbruik per 24 uur	E24h	kWh	3,862	0,869	1,069	1,069
Jaarlijks energieverbruik	AEC	kWh	1410	317	390	390
Nettovolume voor compartiment 1	Vn1	litre	96	96	88	77,5
Nettovolume voor compartiment 2	Vn2	litre	96	96	88	77,5
Nettovolume voor compartiment 3	Vn3	litre	-	-	-	-
Nettovolume voor compartiment 4	Vn4	litre	-	-	-	-
Totaal nettovolume	VnT	litre	192	192	176	155
Klimaatklasse	CC		5	5	5	5
Koelmiddel			R290	R600a	R600a	R600a
Lading		kg	0.055	0.07	0.07	0.07
GWP			3	3	3	3
CO ₂ -equivalent		CO ₂	0,165	0,21	0,24	0,21
Intensief gebruik; dit apparaat is bedoeld voor gebruik in omgevingstemperaturen tot 40 °C			X	X	X	X
Contactgegevens:	HOSHIZAKI EUROPE B.V.					
	Address: Burgemeester Stramanweg 101 1101 AA Amsterdam, The Netherlands Tel.: +31 (0)20 691 84 99 - http://hoshizaki.europe.com/					

HOSHIZAKI

PREMIER UNDERCOUNTER



Handelsmerk			HOSHIZAKI			
Modelnaam			PREMIER F 3 A DL DL DR	PREMIER K/M 3 A DL DL DR	PREMIER K/M 3 A 2D 2D 2D	PREMIER K/M 3 A 3D 3D 3D
Bedoeld gebruik			Storage	Storage	Storage	Storage
Gekoelde bedrijfstemperatuur				X	X	X
Bevroren bedrijfstemperatuur			X			
Multifunctionele kast						
Verticale kast						
Werkbank			X	X	X	X
Parameter	Symbol	Unit				
Energie-efficiëntieklasse	EEC	-	C	A	A	A
Energie-efficiëntie-index	EEl	-	47,98	18,77	21,29	22,02
Energieverbruik per 24 uur	E24h	kWh	5,340	1,299	1.438	1.438
Jaarlijks energieverbruik	AEC	kWh	1949	474	525	525
Nettovolume voor compartiment 1	Vn1	litre	96	96	88	77,5
Nettovolume voor compartiment 2	Vn2	litre	96	96	88	77,5
Nettovolume voor compartiment 3	Vn3	litre	96	96	88	77,5
Nettovolume voor compartiment 4	Vn4	litre	-	-	-	-
Totaal nettovolume	VnT	litre	288	288	264	232
Klimaatklasse	CC		5	5	5	5
Koelmiddel			R290	R290	R290	R290
Lading		kg	0.055	0.065	0.065	0.065
GWP			3	3	3	3
CO2-equivalent		CO ₂	0,165	0,195	0,195	0,195
Intensief gebruik; dit apparaat is bedoeld voor gebruik in omgevingstemperaturen tot 40 °C			X	X	X	X
Contactgegevens:	HOSHIZAKI EUROPE B.V.					
	Address: Burgemeester Stramanweg 101 1101 AA Amsterdam, The Netherlands Tel.: +31 (0)20 691 84 99 - http://hoshizaki.europe.com/					

HOSHIZAKI

PREMIER UNDERCOUNTER



Handelsmerk			HOSHIZAKI			
Modelnaam			PREMIER F 4 A DL DL DR DR	PREMIER K/M 4 A DL DL DR DR	PREMIER K/M 4 A 2D 2D 2D 2D	PREMIER K/M 4 A 3D 3D 3D 3D
Bedoeld gebruik			Storage	Storage	Storage	Storage
Gekoelde bedrijfstemperatuur				X	X	X
Bevroren bedrijfstemperatuur			X			
Multifunctionele kast						
Verticale kast						
Werkbank			X	X	X	X
Parameter	Symbol	Unit				
Energie-efficiëntieklasse	EEC	-	C	A	A	A
Energie-efficiëntie-index	EEl	-	44,77	17,37	21,87	22,79
Energieverbruik per 24 uur	E24h	kWh	5,67	1,319	1,612	1,612
Jaarlijks energieverbruik	AEC	kWh	2070	481	588	588
Nettovolume voor compartiment 1	Vn1	litre	96	96	88	77,5
Nettovolume voor compartiment 2	Vn2	litre	96	96	88	77,5
Nettovolume voor compartiment 3	Vn3	litre	96	96	88	77,5
Nettovolume voor compartiment 4	Vn4	litre	96	96	88	77,5
Totaal nettovolume	VnT	litre	384	384	352	310
Klimaatklasse	CC		4	5	4	4
Koelmiddel			R290	R290	R290	R290
Lading		kg	0.055	0.065	0.065	0.065
GWP			3	3	3	3
CO2-equivalent		CO ₂	0,165	0,195	0,195	0,195
Intensief gebruik; dit apparaat is bedoeld voor gebruik in omgevingstemperaturen tot 40 °C				X		
Contactgegevens:	HOSHIZAKI EUROPE B.V.					
	Address: Burgemeester Stramanweg 101 1101 AA Amsterdam, The Netherlands Tel.: +31 (0)20 691 84 99 - http://hoshizaki.europe.com/					



PREMIER UNDERCOUNTER

II. BEDIENINGSINSTRUCTIES

ELEKTRICITEIT

Voordat het product op het elektriciteitsnet wordt aangesloten, moet u controleren of de opgegeven elektrische spanning op het label met de productbeschrijving overeenkomt met de elektrische spanning van het lokale netwerk.

U vindt het label met de productbeschrijving met de opgegeven elektrische spanning aan de binnenkant van de kast, links bovenaan.

Het product mag alleen worden geïnstalleerd door gekwalificeerde en getrainde servicemedewerkers volgens de specificaties in deze handleiding.

De elektrische beveiliging van deze kast is alleen verzekerd wanneer deze is geaard volgens geldende lokale wetten en richtlijnen.

Het is altijd vereist het product te aarden.

De fabrikant aanvaardt geen enkele verantwoordelijkheid voor schade die voortvloeit uit onjuiste aarding.

Houd u aan alle elektriciteitsvereisten die worden bepaald volgens lokale elektrische voorschriften. De stroomaansluiting van het product en het stopcontact moeten op juiste wijze zijn geaard. Huur zo nodig een gekwalificeerde elektricien in.

ALGEMENE INLEIDENDE CONTROLES

Zorg dat de kast op een vlakke ondergrond staat en rechtop is geplaatst. Gebruik hiervoor zo nodig de verstelbare poten van de kast. Alle poten moeten de grond raken. Dit is nodig voor een juiste werking van de kastdeur.

Plaats de kast niet naast warmteproducerende apparaten, zoals ovens, grills en friteuses. Stel het product niet bloot aan direct zonlicht. Warmte die door muren of vloeren kan worden uitgestraald, moet worden geïsoleerd met geschikt isolatiemateriaal. De kast moet zo ver mogelijk van alle warmtebronnen worden geplaatst.

Als de kast wordt verplaatst, moet u drie uur wachten voordat u het apparaat opnieuw start. Verwijder plastic beschermingsmateriaal of tape van de buitenoppervlakken.

Zorg dat de kast zodanig gepositioneerd is, dat er voldoende lucht van en naar het koelcircuit en rondom het kastoppervlak circuleert. Laat minimaal 500 mm ruimte vrij boven de kast.

Als twee koelkasten of vriezers naast elkaar worden geplaatst, moet er minstens 50 mm ruimte tussen beide kasten worden aangehouden.

Zorg ervoor dat ventilatieopeningen vrij zijn.

INLEIDENDE ELEKTRISCHE CONTROLES

- Controleer of de netspanning en frequentie van het stopcontact overeenkomen met de informatie op het label met de productbeschrijving.
- De kast is aangesloten op een wandstopcontact met een zekering van 13-16 Amp als een serieverbinding.
- Schakel de netzekering uit die is verbonden met de stroomkabel.
- Controleer of de stekker van de kast geschikt is voor gebruik met het beschikbare stopcontact en dat deze goed past.

PREMIER UNDERCOUNTER

EERSTE GEBRUIK EN CONTROLES

Nadat u bovenstaande controles hebt uitgevoerd, is de kast klaar voor gebruik. Bedien de kast met de AAN/UIT-schakelaar.

Nadat de kast is ingeschakeld, wordt de compressor gestart. De compressor blijft ingeschakeld totdat de vooraf ingestelde temperatuur is bereikt. Plaats geen voedsel in de kast totdat de temperatuurinstelling is aangepast aan de vereisten voor het voedsel dat u wilt koelen.

U kunt een nieuwe temperatuur instellen via de controller, zoals wordt beschreven in deze handleiding.



BELANGRIJK

- Zorg dat het product tot de ingestelde temperatuur is gekoeld voordat u voedsel in de kast plaatst.
- Houd u aan het maximale laadvermogen. De maximale schapcapaciteit is een gelijkmatige belasting van 40 kg voor elk schap in rechtopstaande kasten en 20 kg voor schappen en laden in werkbanken.
- Raadpleeg het gedeelte 'Algemene inleidende controles' in deze handleiding voor informatie over de hoeveelheid ruimte die nodig is voor een goede luchtventilatie rond het product.
- Bewaar geen explosieve stoffen, zoals spuitbussen met brandbaar drijfgas, in dit apparaat.
- **In het geval van 1/3 lade kan het containerdeksel met sealapparatuur niet worden gebruikt.**

WAARSCHUWING:

- Blokkeer op geen enkel moment de ventilatieopeningen op het apparaat.
- Gebruik buiten door de fabrikant voorgestelde apparaten, geen apparaten of andere middelen om het ontdooiproces te versnellen.
- Beschadig het koelmiddelcircuit niet.
- Gebruik geen elektrische apparaten in de kast.
- Beschadig het netsnoer, de bedrading of elk ander belangrijk onderdeel niet.
- Var försiktig så att du inte skadar strömkabeln, kablarna eller komponenterna.

BEWAARCONDITIES EN PRESTATIES

Correcte bewaarcondities zijn niet alleen cruciaal voor voedselhygiëne en veiligheid, maar zorgen tevens voor verbeterde servicekwaliteit en verlaagd energieverbruik. Houd de volgende tips en richtlijnen in acht voor optimale prestaties: plaats alle voedingswaren alleen op de schappen en nooit op de bodem van de kast. Zorg bij het plaatsen van voedingswaren in de kast of werkbank dat de lucht vrij rond kan stromen, met voldoende ruimte tussen de items en de wanden van het product. De afstand tussen de schappen kan zo nodig worden aangepast.

HOSHIZAKI

PREMIER UNDERCOUNTER



III. BEDIENINGSPANEEL

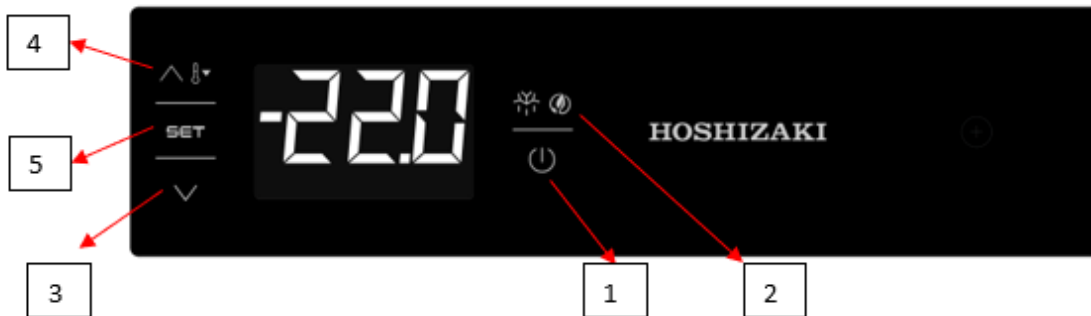

➤ FUNCTIES VAN VOORPANEEL

Om de toetsen op het voorpaneel te vergrendelen, houdt u de AUX-toets (3) en de Aan / Standby-toets (1) 2 seconden ingedrukt: als de toetsen vergrendeld zijn, wordt 'Loc' weergegeven op het scherm, als ze niet vergrendeld zijn, wordt 'UnL' weergegeven.

- 1) Als u de **AAN/STANDBY**-toets 4 seconden ingedrukt houdt, vergrendelt of ontgrendelt u het apparaat. (Aan/Uit)
- 2) **HANDMATIGE ONTDOOIING**; als u deze toets 4 seconden ingedrukt houdt, wordt het handmatige ontdooiingsproces gestart. Het handmatige ontdooiingsproces start niet als de superkoelfunctie is geactiveerd en de verdampertemperatuur niet geschikt is.
- 3) **OMLAAG**-toets: gebruik deze toets om in het menu naar beneden te scrollen of de waarde te verlagen; als u de toets 4 seconden ingedrukt houdt, wordt de superkoelfunctie geactiveerd. Als de superkoelfunctie is geactiveerd, kan de ingestelde temperatuur worden verlaagd; de tijd en temperatuur worden aan de hand van parameters bepaald. Wanneer de superkoelfunctie is geactiveerd, zal het apparaat in geen geval ontdooien.
- 5) **OMHOOG**-toets: gebruik deze toets om in het menu naar boven te scrollen of de waarde te verhogen; als u deze toets 4 seconden ingedrukt houdt, wordt de functie voor het lage en hoge relatieve vochtigheidspercentage actief. (Op sommige modellen) Als de relatieve vochtigheid een laag percentage heeft, wordt 'rhL' weergegeven op het scherm. Heeft de relatieve vochtigheid een hoog percentage, dan wordt 'rhH' weergegeven. Deze functies worden 10 seconden op het scherm weergegeven. Als de vochtigheid niet kan worden gereguleerd, wordt '----' 1 seconde weergegeven op het scherm.
- 6) **SET**-toets: gebruik deze toets om aanpasbare waarden in te voeren of te veranderen.

➤ BEDRIJFSMODI

De mogelijke bedrijfsmodi worden hieronder weergegeven:

'Aan'-status: het apparaat is in bedrijf en wordt van stroom voorzien.

'Standby'-status: het apparaat is uitgeschakeld, maar wordt nog steeds van stroom voorzien.

'Uit'-status: om het apparaat uit te schakelen, verwijdert u de stekker uit het stopcontact of schakelt de hoofdzekering uit.

PREMIER UNDERCOUNTER

IV. AANWIJZINGEN VOOR ONDERHOUD

Het toestel moet regelmatig worden schoongemaakt. De intervallen zijn afhankelijk van het gebruik en de mate van vervuiling (minstens jaarlijks).



Verwijder de stekker uit het stopcontact voordat u schoonmaak- of onderhoudsactiviteiten gaat uitvoeren.



Raak de onderdelen van het machinecompartiment niet aan en maak ze niet nat. Dit kan leiden tot storingen of defecten.



Voorkom mogelijke schade door de kunststof onderdelen niet met water warmer dan 40 °C of in een afwasmachine te reinigen.

Binnen- en buitenkant van kast en schappen



Maak de binnen- en buitenkant ten minste éénmaal per week schoon om een hygiënisch gebruik te waarborgen.



Veeg de binnen- en buitenkant schoon met een zachte doek die in koud of warm water met de juiste hoeveelheid van een neutraal schoonmaakmiddel is gedompeld en vervolgens goed uitgewrongen. Gebruik geen waterstraal om het machinecompartiment schoon te maken.



Andere chemische middelen dan een neutraal schoonmaakmiddel kunnen de oppervlakken aan binnen- en buitenkant beschadigen.



Eventueel achtergebleven reinigingsmiddel brengt schade toe aan metalen of kunststof oppervlakken. Gebruik een zachte doek die is bevochtigd met warm water om het weg te vegen.



Vermijd het gebruik van de volgende producten, deze kunnen schade toebrengen aan geverfde of kunststof oppervlakken:

- Polijstpoeder, alcohol, thinner, benzeen, zuurhoudende of alkalische reinigingsmiddelen, heet water, petroleum, zeepoeder, metalen sponsjes of borstels enz. Dit geldt in het bijzonder voor reinigingsmiddelen die worden gebruikt voor het verwijderen van vet bij ventilatoren of magnetrons.

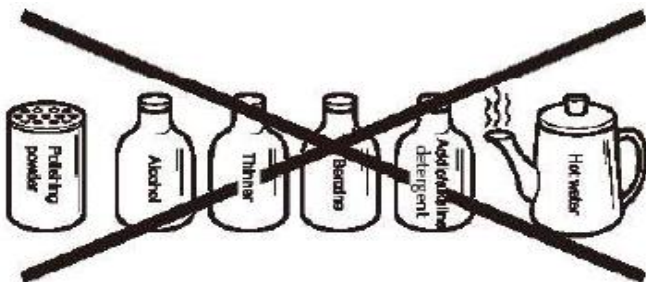

Opmerking: sommige andere oplossingen dan hierboven worden genoemd kunnen eveneens schade toebrengen aan geverfde of kunststof oppervlakken. Stop onmiddellijk met het gebruik van dergelijke oplossingen als deze problemen veroorzaken!

PREMIER UNDERCOUNTER



De deurafdichting en het contactoppervlak kunnen gemakkelijk verontreinigd raken. Maak deze onderdelen zorgvuldig schoon. Voedselresten leiden tot een versnelde slijtage.



Gebruik een doek om overgebleven water binnen in de behuizing weg te vegen.

Condensator



Gebruik een stofzuiger of zachte borstel om stof en vuil van de condensator te verwijderen.



Waarschuwing: **gebruik geen harde borstel, zoals een afwasborstel, om de condensator schoon te maken. Hierdoor kan de coating beschadigd raken.**

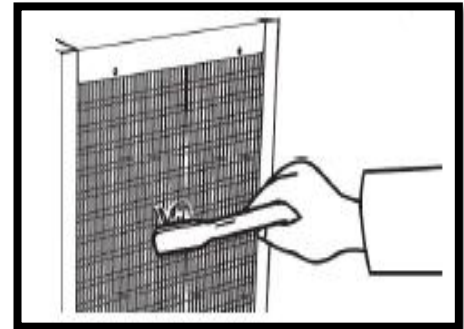

Luchtfilter



Voorkom vervorming van het luchtfilter door dit schoon te maken met water van niet meer dan 40 °C.



Kunststof luchtfilters halen vuil en stof uit de lucht en voorkomen dat de condensator verstopt raakt. Als de filters verstopt raken, gaat de koelkast/vriezer minder goed werken.



Controleer de filters minstens tweemaal per maand. Als ze verstopt zijn of als de temperatuurregelaar 'cH' aangeeft, reinigt u de filters met warm water en een neutraal schoonmaakmiddel. Gebruik het apparaat niet terwijl de luchtfilters zijn verwijderd. Als u dat wel doet, raakt de condensator verstopt en treden er storingen op.

- 1) Open het voorpaneel en verwijder het luchtfilter. Raak de vinnen van de condensator niet rechtstreeks aan om letsel te voorkomen.
- 2) Was het luchtfilter zorgvuldig met koud of warm water dat de juiste hoeveelheid van een neutraal schoonmaakmiddel bevat. Spoel het luchtfilter schoon en droog het zorgvuldig af.
- 3) Om het luchtfilter weer terug te plaatsen, steekt u de twee lipjes in de warmtewisselaar of de vinnen in de condensator en bevestigt u het luchtfilter stevig over de condensator.

PREMIER UNDERCOUNTER

V. TECHNISCHE INFORMATIE AFMETINGEN VAN DE APPARATEN

PREMIER K-M-F 2 A DL DR L

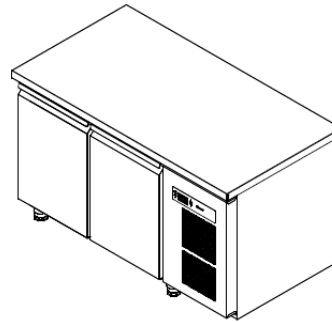
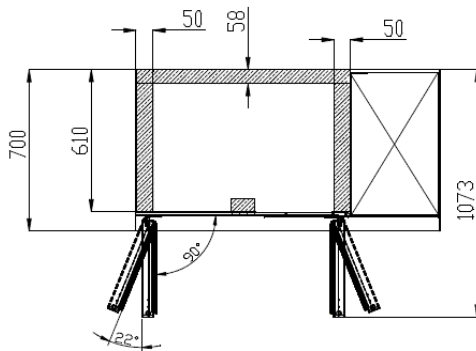
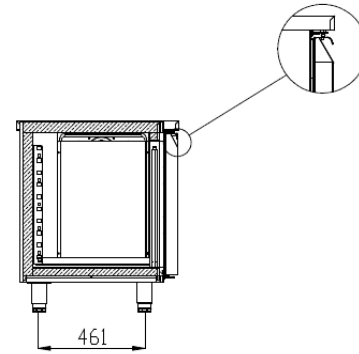
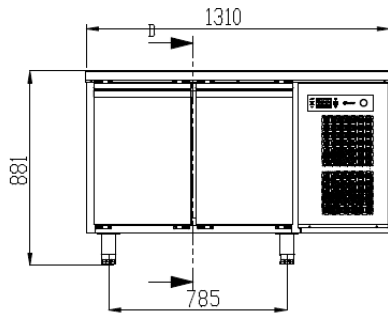

PREMIER K-M-F 2 A DL DR C

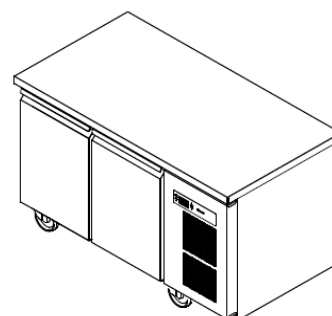
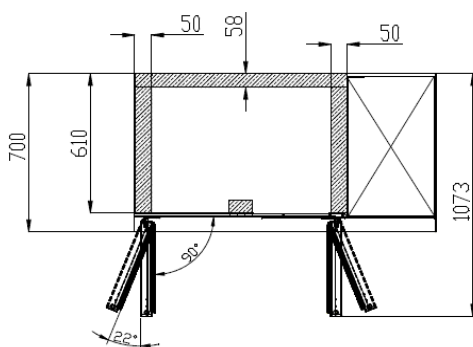
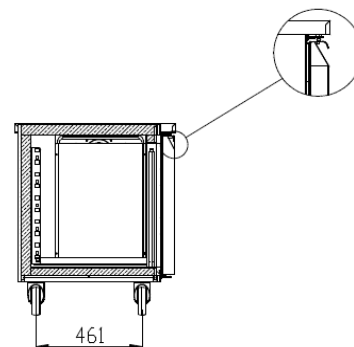
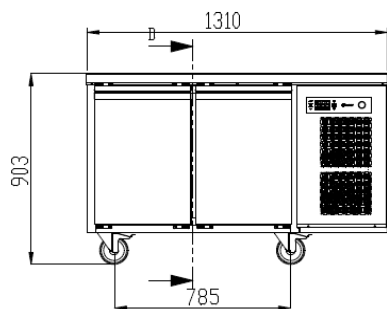

HOSHIZAKI

PREMIER UNDERCOUNTER



PREMIER K-M 2 A 2D 2D L

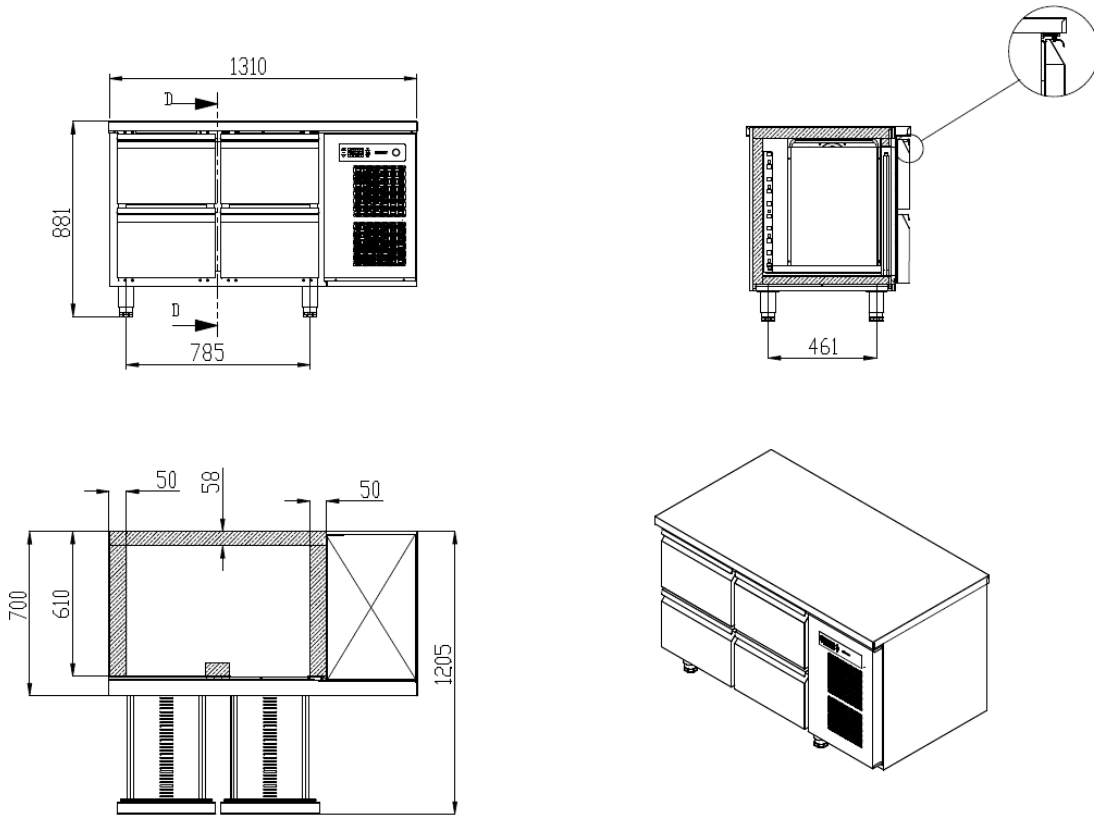

PREMIER K-M 2 A 2D 2D C

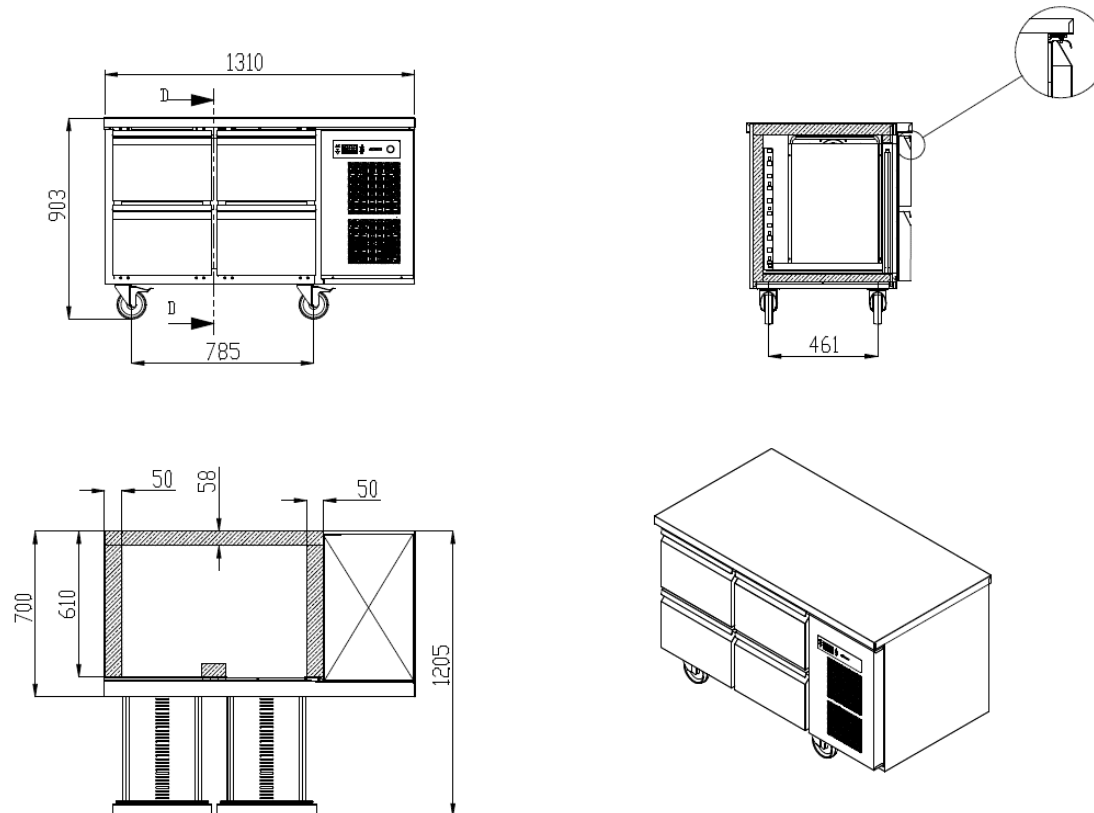

HOSHIZAKI

PREMIER UNDERCOUNTER



PREMIER K-M 2 A 3D 3D L

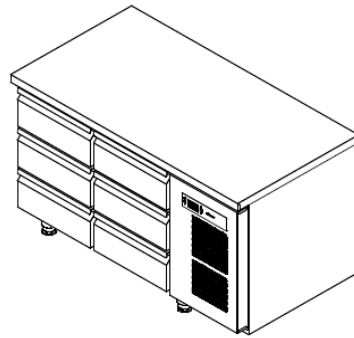
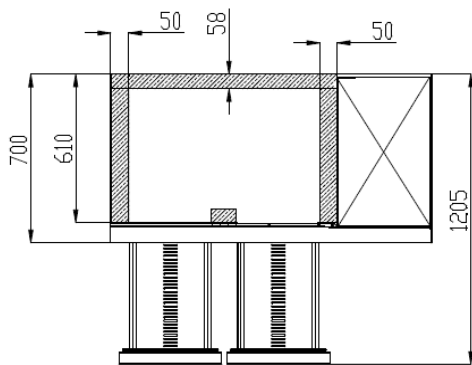
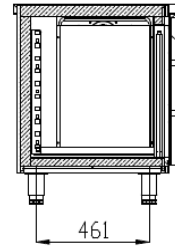
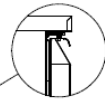
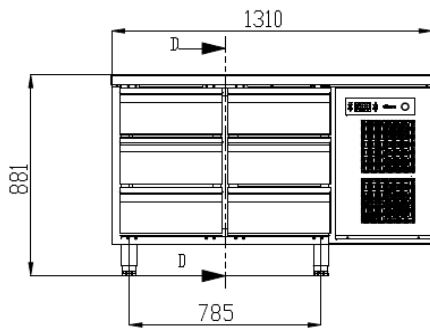

PREMIER K-M 2 A 3D 3D C

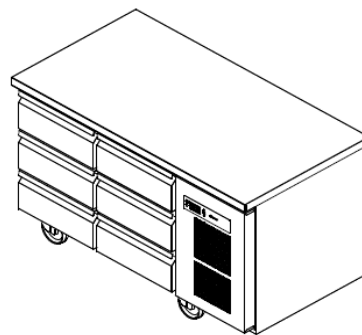
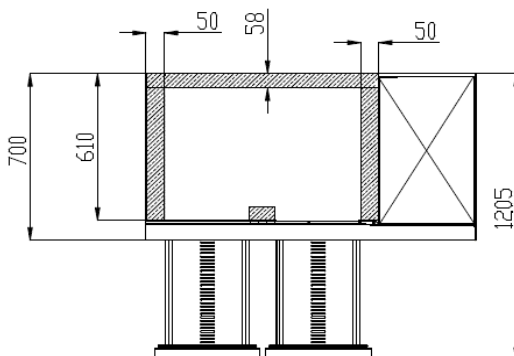
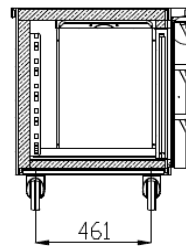
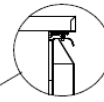
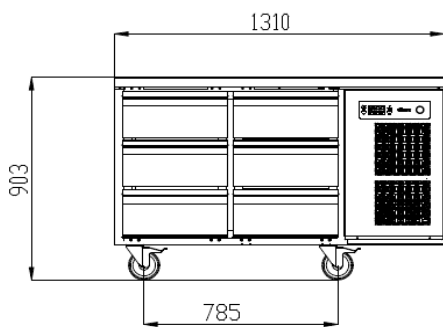

HOSHIZAKI

PREMIER UNDERCOUNTER



PREMIER K-M-F 3 A DL DR DR L

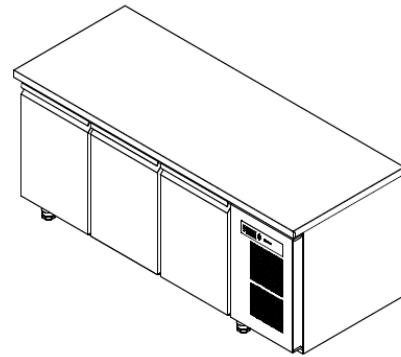
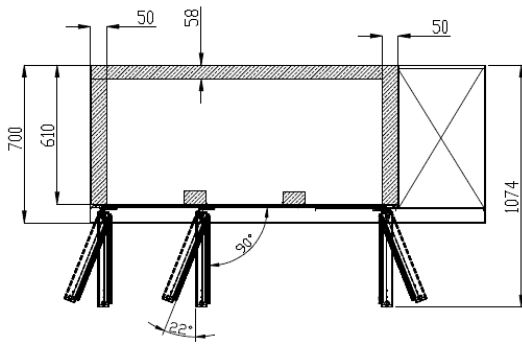
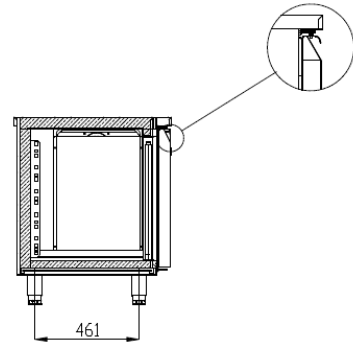
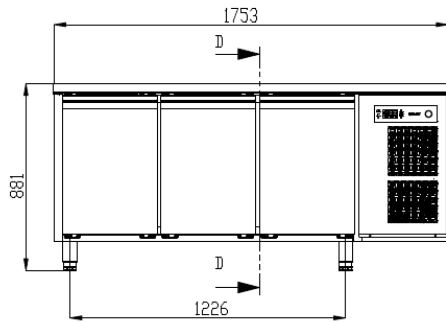

PREMIER K-M-F 3 A DL DR DR C

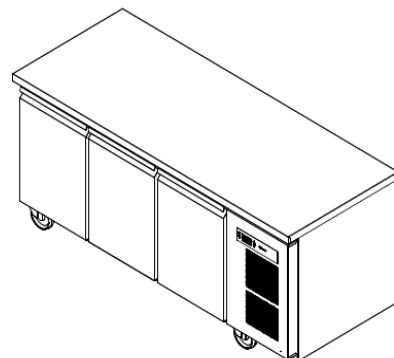
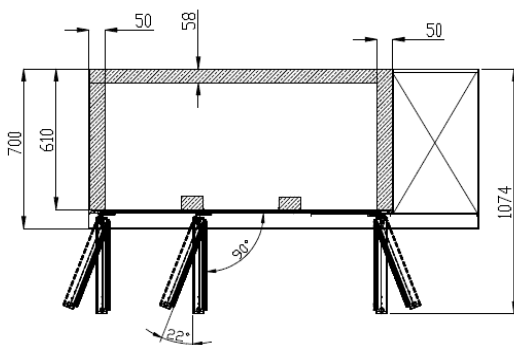
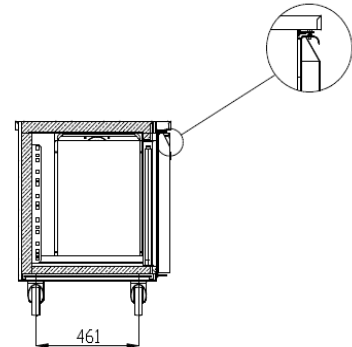
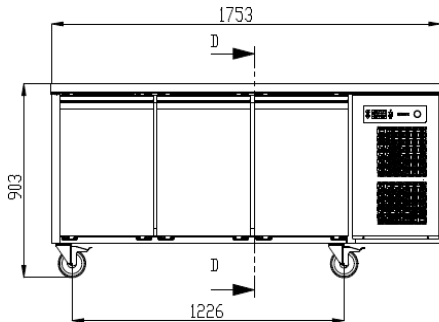

HOSHIZAKI

PREMIER UNDERCOUNTER



PREMIER K-M 3 A 2D 2D 2D L

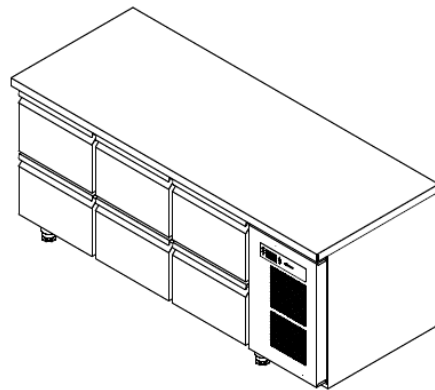
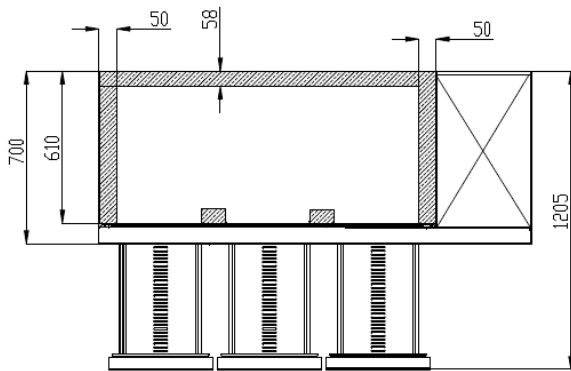
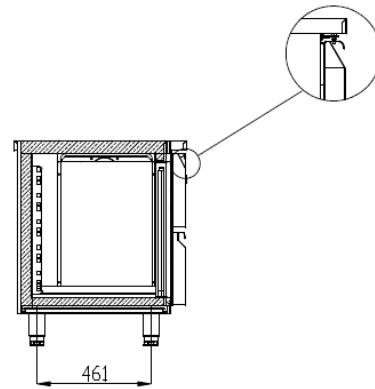
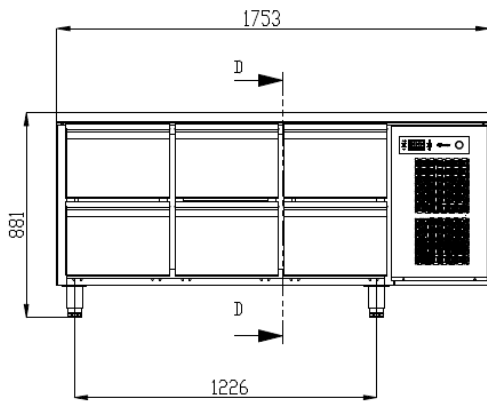

PREMIER K-M 3 A 2D 2D 2D C

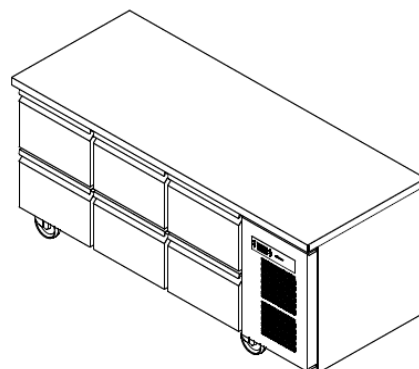
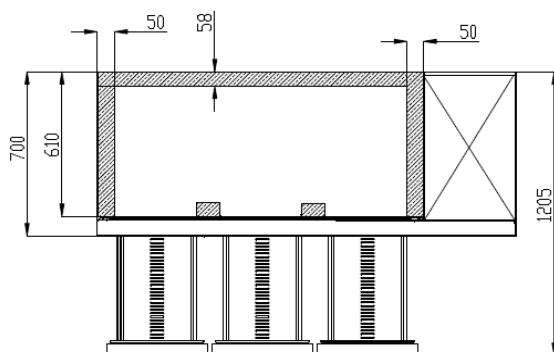
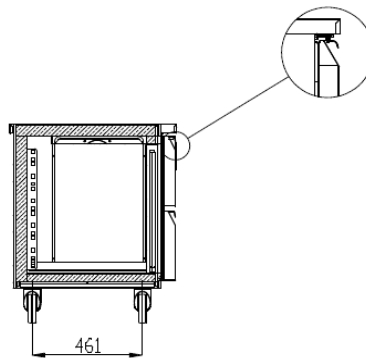
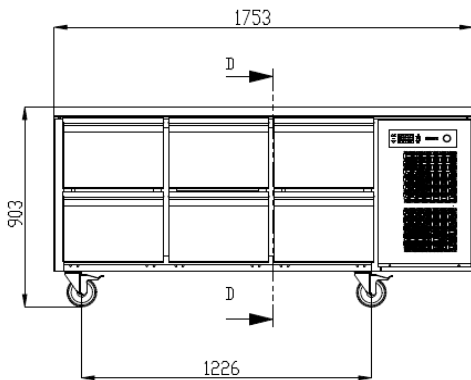

HOSHIZAKI

PREMIER UNDERCOUNTER



PREMIER K-M 3 A 3D 3D 3D 3 L

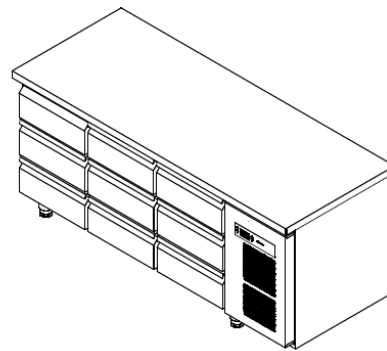
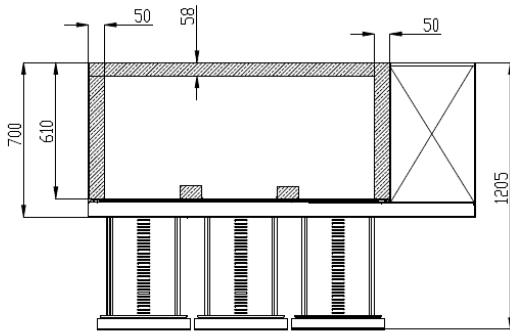
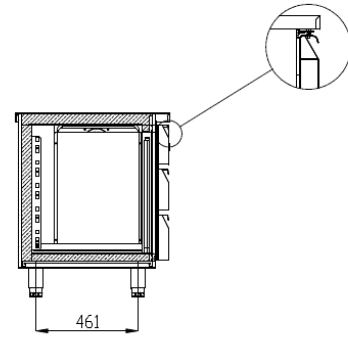
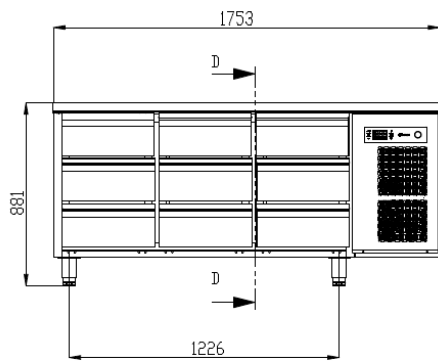

PREMIER K-M 3 A 3D 3D 3D 3 C

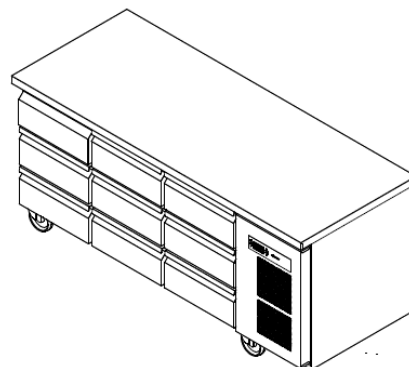
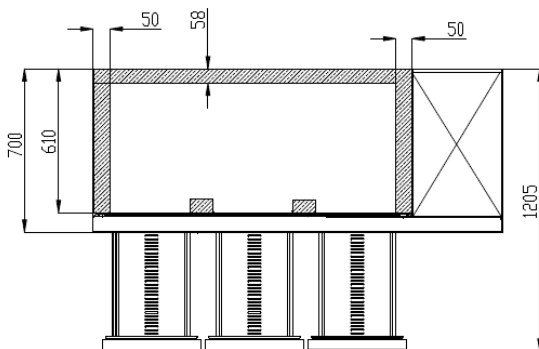
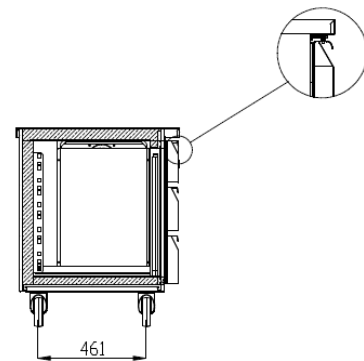
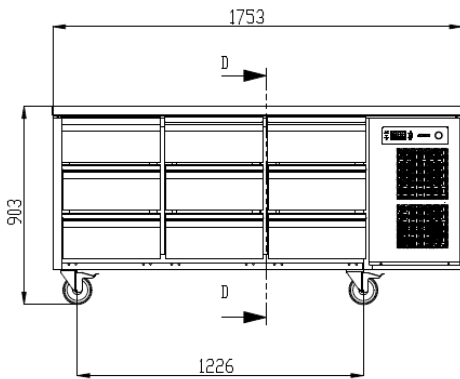

HOSHIZAKI

PREMIER UNDERCOUNTER



PREMIER K-M-F 4 A DL DL DR DR L

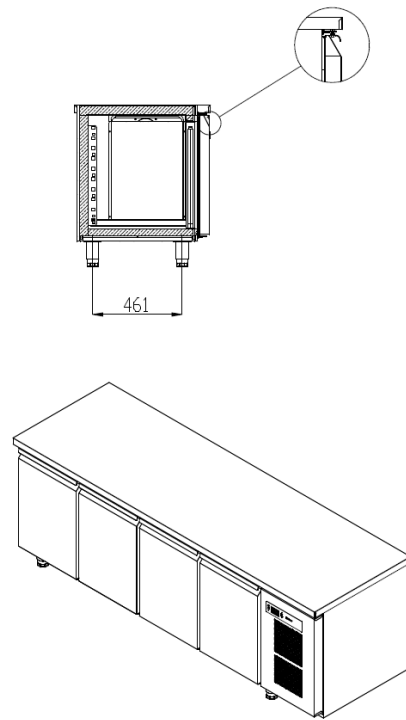
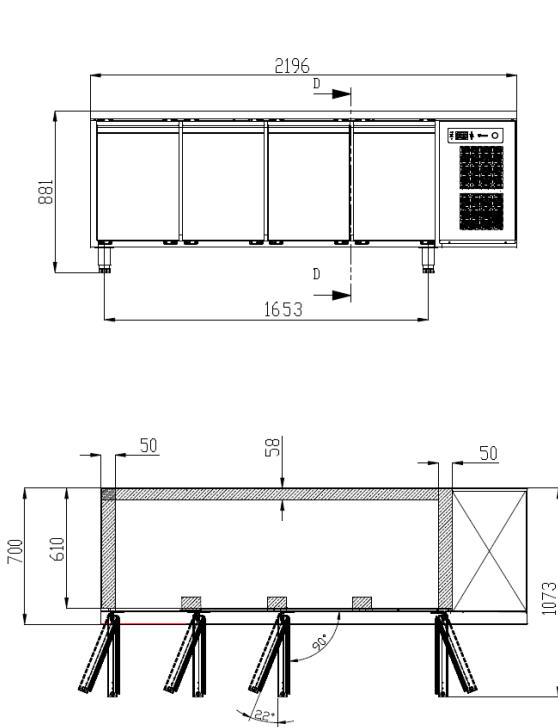

PREMIER K-M-F 4 A DL DL DR DR C

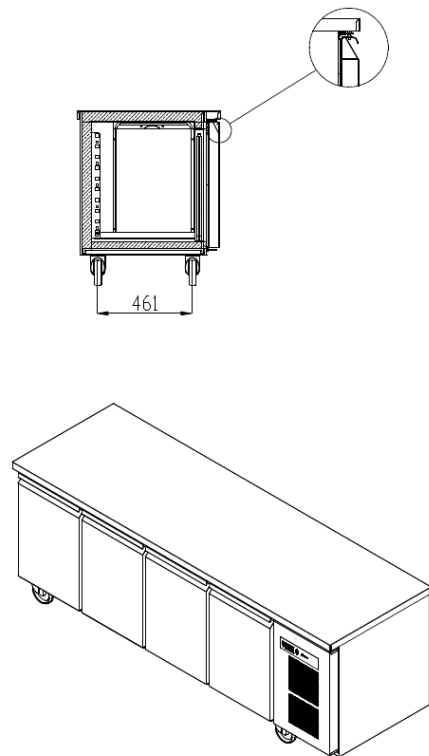
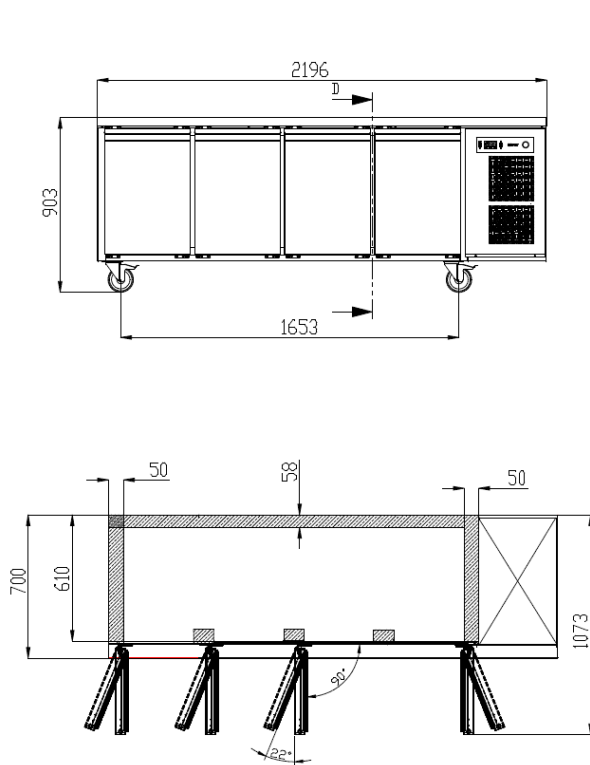

HOSHIZAKI

PREMIER UNDERCOUNTER



PREMIER K-M 4 A 2D 2D 2D 2D L

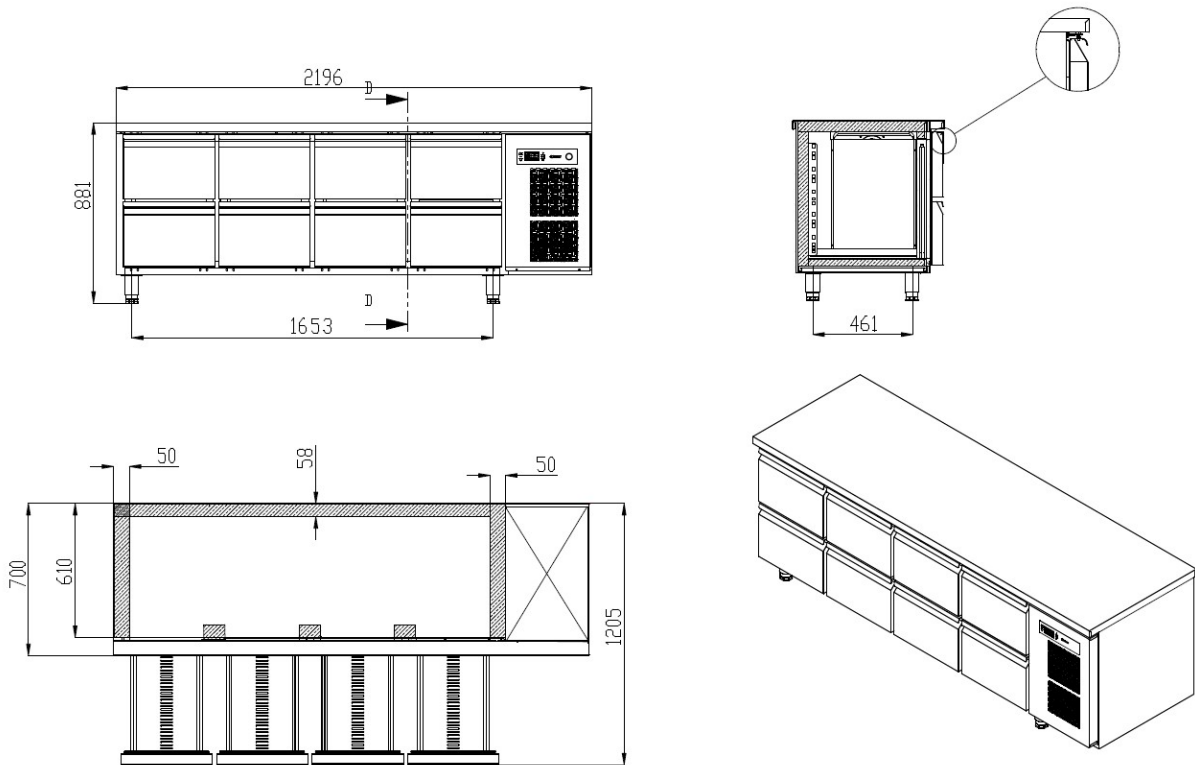

PREMIER K-M 4 A 2D 2D 2D 2D C

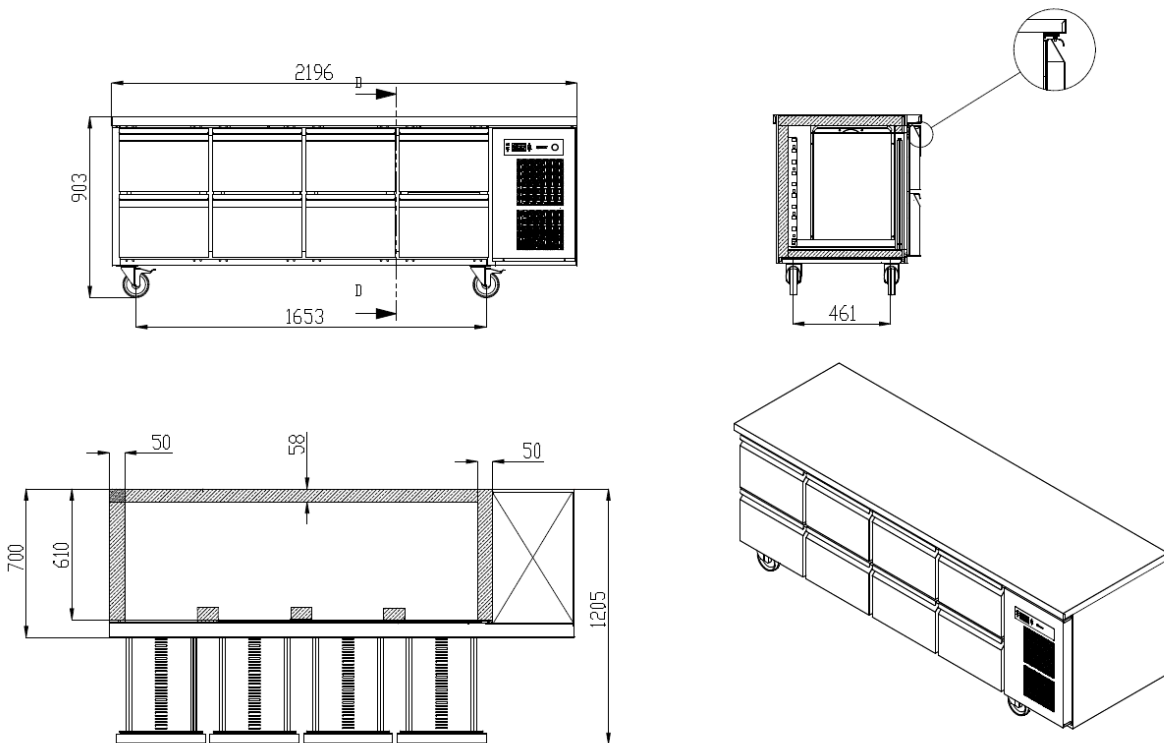

HOSHIZAKI

PREMIER UNDERCOUNTER



PREMIER K-M 4 A 3D 3D 3D 3D L

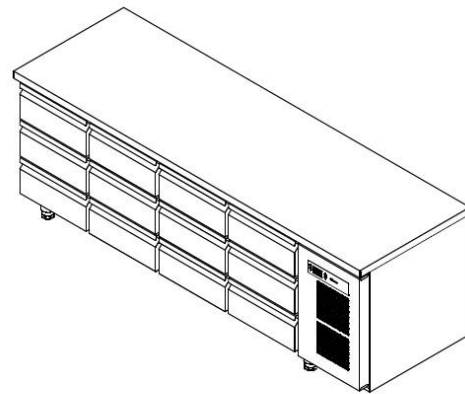
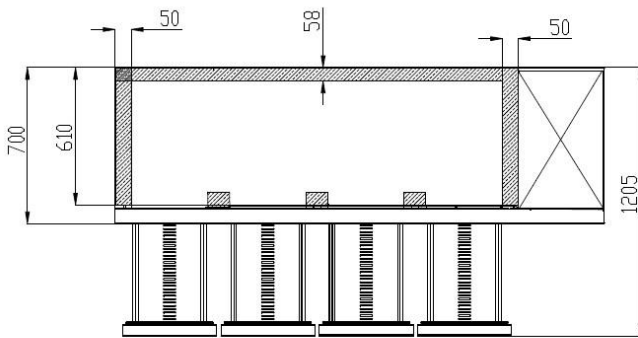
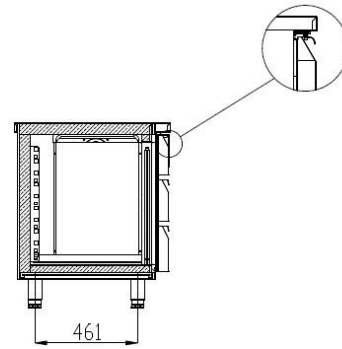
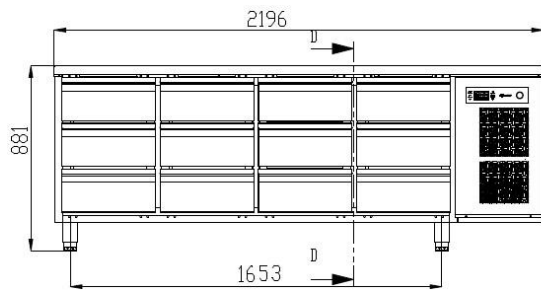

PREMIER K-M 4 A 3D 3D 3D 3D C

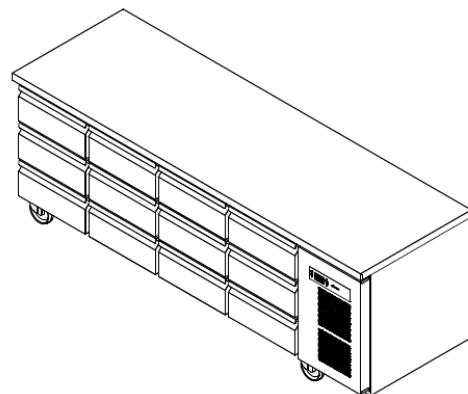
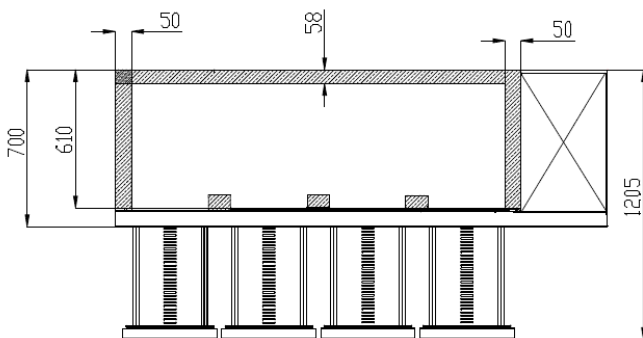
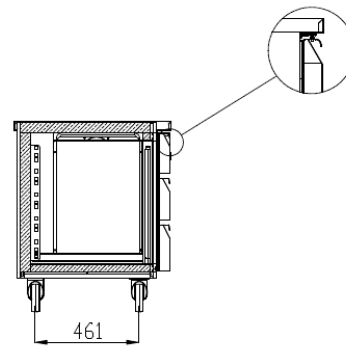
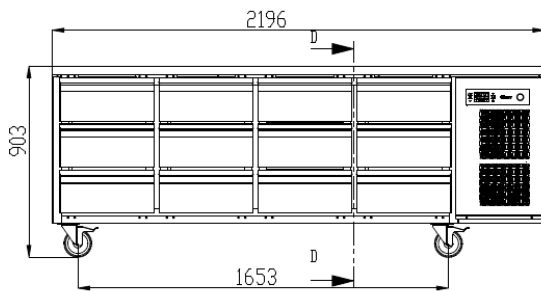

HOSHIZAKI

PREMIER UNDERCOUNTER



VI. KOELSCHEMA - BEDRADINGSSHEMA

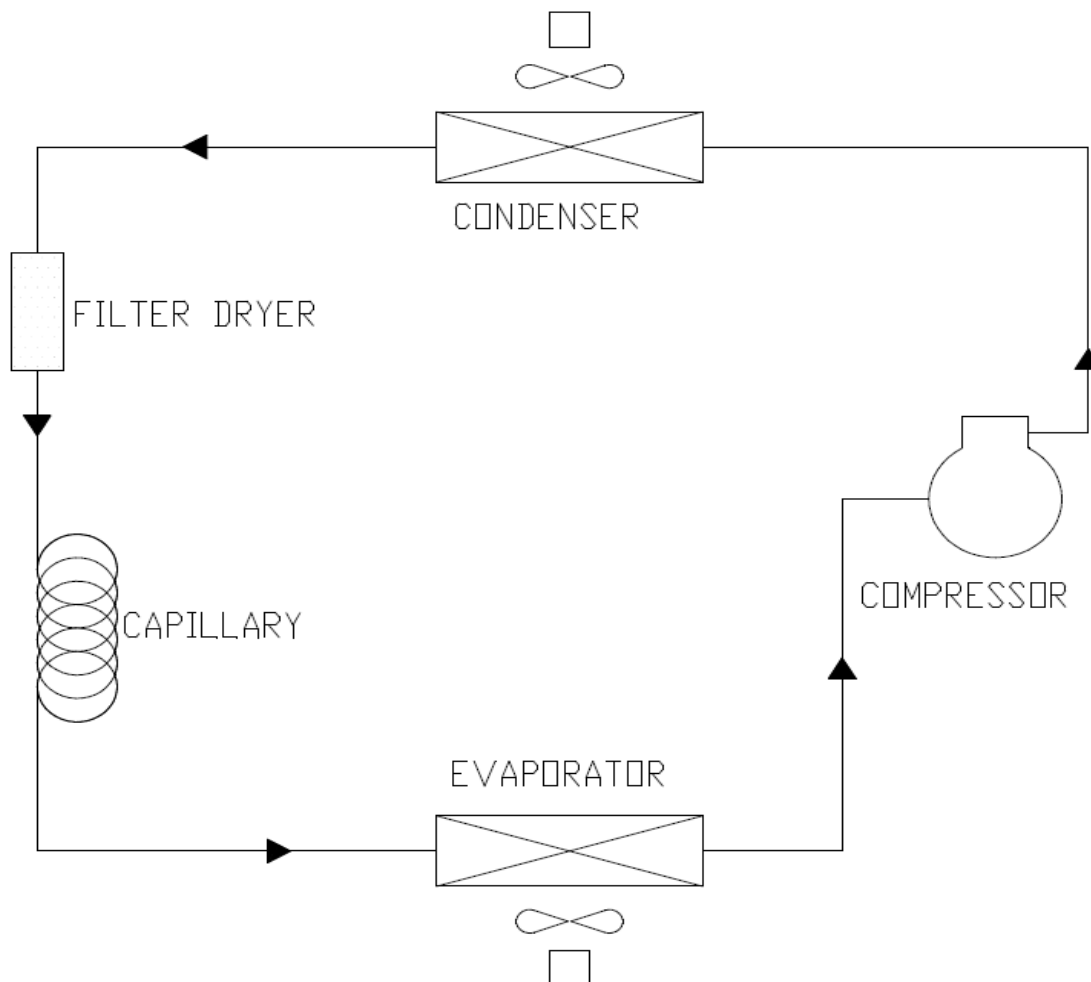



HOSHIZAKI

PREMIER UNDERCOUNTER

BEDRADINGSSCHEMA

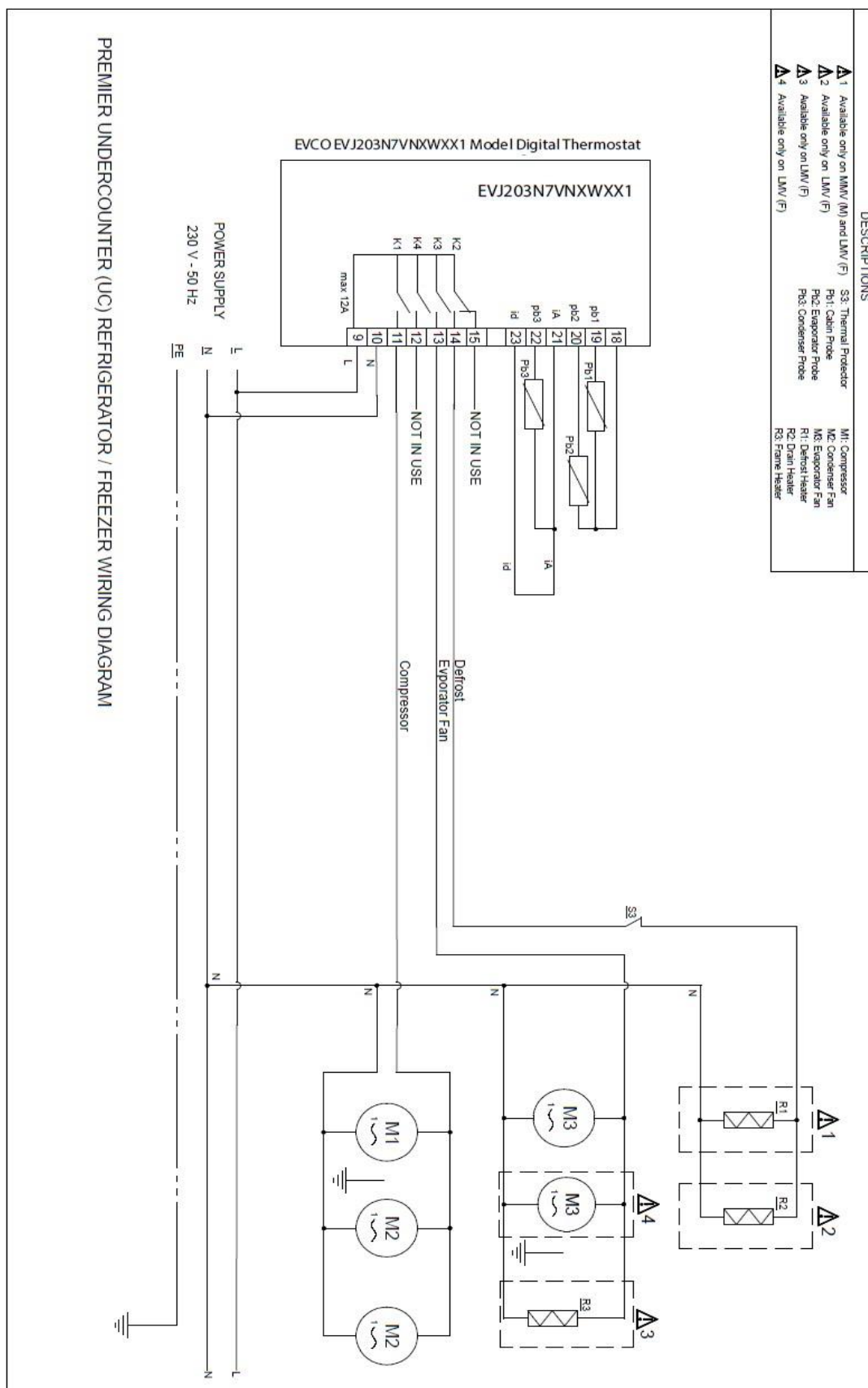

PREMIER UNDERCOUNTER

VII. OPSPOREN EN VERHELPEN VAN STORINGEN

In onderstaande tabel worden verschillende problemen beschreven die kunnen optreden. Als een alarmcode wordt weergegeven, is een storing opgetreden. Los alle mogelijke oorzaken op voordat u de kast reset. Mogelijke oorzaken en oplossingen worden hieronder beschreven.

Als een foutcode zich blijft voordoen nadat u onderstaande controles hebt uitgevoerd, moet u contact opnemen met een geautoriseerde monteur. Bepaal de kenmerken van het foutbericht. Productdetails, zoals het serienummer, vindt u op het typeplaatje van het product.

PROBLEEM	MOGELIJKE OORZAAK	OPLOSSING	
De kast werkt niet	De kast krijgt geen stroom	Controleer de stekker en het netsnoer	
De compressor blijft bijna continu werken	De omgevingstemperatuur is te hoog	Verbeter de ventilatie	
	De condensator of het condensatorfilter is geblokkeerd	Controleer en reinig regelmatig het condensatorfilter	
	Deurpakkingen dicht niet volledig af	Vraag een geautoriseerde monteur de afdichtingen te vervangen	
	Ijsvorming in de verdamper	Plaats geen hete voedingswaren in de kast	Plaats alleen voedingswaren met een hoog vochtgehalte in de kast als deze zijn verpakt in afgesloten bakjes
		Start een handmatige ontdooicyclus	
De ventilator(en) van de verdamper zijn defect	Vraag een geautoriseerde monteur de ventilator(en) te vervangen		
Er stroomt water over van de waterbak van de condensator	Er worden vaak hete voedingswaren in de kast geplaatst	Plaats geen hete voedingswaren in de kast	
		Plaats alleen voedingswaren met een hoog vochtgehalte in afgesloten bakjes in de kast	
	De deur of laden worden vaak geopend	Controleer de kastspecificaties en ga na of deze geschikt zijn voor het huidige gebruik	
Kasttemperatuur is hoog	De condensator is geblokkeerd met vuil en stof	Controleer en reinig regelmatig het condensatorfilter	
	De luchtstroom binnen de kast is geblokkeerd	Verwijder eventuele voedingswaren die de luchtstroom blokkeren	
	Omgevingslucht stroomt in de kast	Zorg dat de deur is gesloten	
		Controleer of de deur of deurafdichtingen zijn beschadigd	
		Neem contact op met een geautoriseerde monteur	
Ijsvorming in de verdamper	Start een handmatige ontdooicyclus		

PREMIER UNDERCOUNTER

VIII. VERWIJDEREN EN VERVANGEN

DE KAST VERWIJDEREN

- U vindt op het typeplaatje welk koelgas aanwezig is in de kast.
- De kast wordt geproduceerd van recyclebare materialen overeenkomstig EU-regelgeving. Aan het einde van de economische levensduur van de kast moet de kast daarom naar een passend recyclingcentrum worden gebracht.
- Recycle de kast niet als metaal of huishoudelijk afval.
- Zorg dat het koelcircuit van de koelinstallatie niet in elkaar wordt gedrukt.



BELANGRIJK

Houd u aan de lokale wet- en regelgeving tijdens het verwijderen van de kast.



PREMIER UNDERCOUNTER

Alle rechten voorbehouden. Hoshizaki behoudt zich het recht voor functies en de inhoud van deze handleiding te wijzigen.

Contactgegevens

Hoofdkantoor

Hoshizaki Europe B.V – All other countries in Europe and Africa

TEL: +31 (0)20 6918499

sales@hoshizaki.nl -- <http://hoshizaki-europe.com/>

Vestigingen

Hoshizaki UK - UK, Ireland

TEL: +44 (0)845 456 05 85

uksales@hoshizaki.co.uk

Hoshizaki Deutschland - Germany, Switzerland, Austria

TEL: +49 (0)5121 697370

vertrieb@hoshizaki.de

Hoshizaki Benelux - Netherlands, Belgium, Luxembourg

TEL: +31 (0)85 0188370

info@hoshizaki.nl

Hoshizaki France - France

TEL: +33 (0)1 48 63 93 80

info@hoshizaki.fr

Hoshizaki Iberia - Spain, Portugal

TEL: +34 (0)93 478 09 52

info@hoshizaki.es

Hoshizaki Denmark - Denmark

TEL: +45 89 88 53 50

salg@hoshizaki.dk

Hoshizaki Norway - Norge

TEL: +47 22 88 17 50

salg@hoshizaki.no

Hoshizaki Sweden - Sverige

TEL: +46 108 84 87 47

OrderSE@hoshizaki.dk

Hoshizaki Italia – Italia

TEL: +39 348 3022156

commerciale@hoshizaki.it

HOSHIZAKI

PREMIER UNDERCOUNTER



PREMIER UNDERCOUNTER

KØLESKABE OG FRYSESKABE BETJENINGS-, VEDLIGEHOLDELSSES- OG INSTALLATIONSVEJLEDNING



I. GENERELLE OPLYSNINGER	132
II. BETJENINGSANVISNINGER	137
III. STYREPANEL	139
IV. VEDLIGEHOLDELSSESANVISNINGER	140
V. TEKNISKE OPLYSNINGER	142
VI. KØLEDIAGRAM – ELEKTRISK LEDNINGSDIAGRAM	151
VII. SERVICEDIAGNOSE	153
VIII. AFMONTERING OG UDSKIFTNING	154

Kontaktoplysninger:

HOSHIZAKI EUROPE B.V.

Adresse: Burgemeester Stramanweg 101 1101 AA Amsterdam, Holland

Tlf.: +31 (0)20 691 8499 <http://hoshizaki-europe.com/>



PREMIER UNDERCOUNTER

I. GENERELLE OPLYSNINGER

MÆRKAT MED PRODUKTBEKRIVELSE

1 - Produktnummer
2 - Produktbeskrivelse
3 - Model
4 - Kølemiddel (GWP)
5 - CO ₂ -ækvivalent
6 - IP-beskyttelse
7 - Klimaklasse
8 - Produktionsdato
9 - Samlet strømforbrug / strøm / lampeeffekt
10 - Spænding - Frekvens
11 - Varmeelement
12 - Systemtryk
13 - Drivmiddel
14 - Serienummer

PRODUCT NUMBER	1
	
PRODUCT DESCRIPTION	2
MODEL	3
REFRIGERANT	4
CO2 EQUIVALENT	5
IP PROTECTION	6
CLIMATE CLASS	7
PRODUCTION DATE	8
TOTAL POWER / CURRENT / LAMP POWER	9
VOLTAGE - FREQUENCY	10
HEATING ELEMENT	11
SYSTEM PRESSURE	12
BLOWING AGENT	13

S/N: 14



HOSHIZAKI EUROPE B.V. Burgemeester Stramanweg 101 1101 AA
Amsterdam, The Netherlands



ANVENDELSESFØRMÅL

- Dette produkt er kun egnet til brug indendørs og udelukkende med det formål at opbevare mad og drikkevarer. Opbevaringsenheder designet til opbevaring af produkter, der allerede har køle-/fryseskabstemperatur.
- Producenten er ikke ansvarlig for eventuelle skader, der opstår som følge af brug i strid med de angivne retningslinjer i denne vejledning.
- Ved opbevaring af fødevarer i dette skab skal det sikres, at fødevarer aldrig kommer i kontakt med indersiden af dette skab.
- Alle fødevarer skal være helt tildækket. For at undgå forurening og korrosion af interne komponenter bør alle produkter pakkes ind eller opbevares i forseglede beholdere.
- Opbevar ikke varme fødevarer eller væsker i dette skab.
- Drikkevarer, der opbevares i bokse og glasflasker, bør ikke opbevares ved temperaturer under 0 °C (frysepunktet). Dåser og glasflasker kan udvide sig og sprænges. Beholdere med låg bør ikke fyldes helt: Der skal være en lille smule plads til udvidelse.
- Dette skab har en automatisk selvafrimningsfunktion. Det er også muligt at udføre manuel afrimning. Ved den manuelle afrimning er det ikke nødvendigt at slukke for skabet i længere perioder, da det kan udføres via styreenheden. Der må under ingen omstændigheder bruges magt eller håndværktøj til at afrime dette skab. Skader, der opstår som følge af en sådan handling, er vanskelige at reparere.
- Anvend ikke mekaniske eller alternative metoder til afrimning.
- Udstyret er ikke beregnet til at blive brugt af personer (herunder børn) med nedsatte fysiske, sensoriske eller psykiske evner eller mangelfuld erfaring eller viden, medmindre de er under opsyn eller har modtaget vejledning i brug af udstyret.
- Børn må ikke lege med udstyret.
- Børn må ikke udføre rengøring og vedligeholdelse uden overvågning.

PREMIER UNDERCOUNTER

- Udstyret kan anvendes af børn fra 8 år og opefter og af personer med nedsatte fysiske, sensoriske eller psykiske evner eller mangelfuld erfaring eller viden, hvis de er under opsyn eller har fået vejledning vedrørende brug af udstyret på en sikker måde og forstår de involverede risici.
- Enhver elektrisk eller mekanisk ændring af dette skab vil gøre garantien ugyldig. Ændringer udført af ikke-autoriserede serviceteknikere og ændringer ud over dem, der er beskrevet i denne vejledning, vil også gøre garantien ugyldig. Producenten påtager sig intet ansvar for skader, der opstår som følge af sådanne ændringer.

KLIMAKLASSE

Skabet er designet til at køre inden for specifikke, omgivende temperatur- og luftfugtighedsniveauer. Disse er fastsat i klimaklassensystemet. Disse niveauer må aldrig overskrides. Klimaklassen for dette produkt kan findes på produktbeskrivelsesmærkaten. Køleskabet er ikke egnet til brug i temperaturer under en omgivelsestemperatur på 16 °C .

Klimaklasse	Omgivende temperaturer og fugtighed
4	+30 °C med 55 % RH
5	+40 °C med 40 % RH

FØRSTE ACCEPT OG KONTROLLER

Dette skab er pakket i beskyttende emballagemateriale til forsendelse. Ved levering skal du kontrollere skabet for eventuelle transportskader, og at skabsmodellen er den, du har bestilt.



VIGTIGT

Alle handlinger, der er anført nedenfor, skal fuldt ud overholde alle lokale vedtægter og sikkerhedsbestemmelser. Overhold alle gældende sikkerhedsregler, når du betjener dette produkt.

TRANSPORT

Når produktet løftes ved hjælp af maskiner, skal løftekapaciteten for de pågældende maskiner verificeres, før sådanne procedurer udføres.



VIGTIGT

Når du bruger en gaffeltruck til at flytte produktet, skal du sørge for, at gaflerne sættes ind i de relevante åbninger i pallen.

Ved bevægelse skal du være opmærksom på, at produktet står stabilt. Hvis tyngdepunktet ikke er i midten af produktet, kan det vælte. Når du sænker produktet med en gaffeltruck, skal det gøres langsomt og omhyggeligt.

Skulle det blive nødvendigt at transportere opretstående skabe i vandret position, skal skabet stå oprejst i mindst 2 timer før brug. Det anbefales ikke at transportere opretstående skabe i vandret position, og skader som følge af en sådan handling er ikke dækket af garantien.

PREMIER UNDERCOUNTER



BEMÆRK

Anbefalingerne på ydersiden af transportemballagen er til hjælp til brugeren. Derfor skal følgende anbefalinger overholdes:

- Produktet skal bæres forsigtigt.
- Hold produktet tørt. Brug ikke toppen af skabet til opbevaring!

ÅBNING AF EMBALLAGEN

- Fjern pap og eventuelt andet emballagemateriale.
- Løft skabet for at fjerne det fra pallen.
- Placer skabet på den ønskede placering stående på sin egen fod.
- Tjek, om der er synlige skader.
- Emballagematerialer kan genbruges i henhold til lokale genbrugsbestemmelser.
- Kontroller, at produktkoden og serienummeret stemmer overens på alle forsendelsesdokumenter.

Varemærke			HOSHIZAKI			
Modelnavn			PREMIER F 2 A DL DR	PREMIER K/M 2 A DL DR	PREMIER K/M 2 A 2D 2D	PREMIER K/M 2 A 3D 3D
Tilsluttet anvendelse			Storage	Storage	Storage	Storage
Køledriftstemperatur				X	X	X
Frysedriftstemperatur			X			
Skab med flere funktioner						
Lodret skab						
Kølebord			X	X	X	X
Parameter	Symbol	Unit				
Energieffektivitetsklasse	EEC	-	C	A+	A	A
Energieffektivitetsindeks	EEL	-	40,26	13,9	17,42	17,85
24 timers energiforbrug	E24h	kWh	3,862	0,869	1,069	1,069
Årligt energiforbrug	AEC	kWh	1410	317	390	390
Nettovolumen for rum 1	Vn1	litre	96	96	88	77,5
Nettovolumen for rum 2	Vn2	litre	96	96	88	77,5
Nettovolumen for rum 3	Vn3	litre	-	-	-	-
Nettovolumen for rum 4	Vn4	litre	-	-	-	-
Nettovolumen i alt	VnT	litre	192	192	176	155
Klimaklasse	CC		5	5	5	5
Kølemiddel			R290	R600a	R600a	R600a
Belastning		kg	0.055	0.07	0.07	0.07
GWP			3	3	3	3
CO ₂ -ækvivalent		CO ₂	0,165	0,21	0,24	0,21
Robust. Dette apparat er beregnet til brug i omgivelsestemperaturer op til 40 °C			X	X	X	X
Kontaktoplysninger:			HOSHIZAKI EUROPE B.V.			
			Address: Burgemeester Stramanweg 101 1101 AA Amsterdam, The Netherlands Tel.: +31 (0)20 691 84 99 - http://hoshizaki.europe.com/			

HOSHIZAKI

PREMIER UNDERCOUNTER



Varemærke			HOSHIZAKI			
Modelnavn			PREMIER F 3 A DL DL DR	PREMIER K/M 3 A DL DL DR	PREMIER K/M 3 A 2D 2D 2D	PREMIER K/M 3 A 3D 3D 3D
Tilsluttet anvendelse			Storage	Storage	Storage	Storage
Køledriftstemperatur				X	X	X
Frysedriftstemperatur			X			
Skab med flere funktioner						
Lodret skab						
Kølebord			X	X	X	X
Parameter	Symbol	Unit				
Energieffektivitetsklasse	EEC	-	C	A	A	A
Energieffektivitetsindeks	EEI	-	47,98	18,77	21,29	22,02
24 timers energiforbrug	E24h	kWh	5,340	1,299	1.438	1.438
Årligt energiforbrug	AEC	kWh	1949	474	525	525
Nettovolumen for rum 1	Vn1	litre	96	96	88	77,5
Nettovolumen for rum 2	Vn2	litre	96	96	88	77,5
Nettovolumen for rum 3	Vn3	litre	96	96	88	77,5
Nettovolumen for rum 4	Vn4	litre	-	-	-	-
Nettovolumen i alt	VnT	litre	288	288	264	232
Klimaklasse	CC		5	5	5	5
Kølemiddel			R290	R290	R290	R290
Belastning		kg	0.055	0.065	0.065	0.065
GWP			3	3	3	3
CO2-ækvivalent		CO ₂	0,165	0,195	0,195	0,195
Robust. Dette apparat er beregnet til brug i omgivelsestemperaturer op til 40 °C			X	X	X	X
Kontaktoplysninger:	HOSHIZAKI EUROPE B.V.					
	Address: Burgemeester Stramanweg 101 1101 AA Amsterdam, The Netherlands Tel.: +31 (0)20 691 84 99 - http://hoshizaki.europe.com/					

HOSHIZAKI

PREMIER UNDERCOUNTER



Varemærke			HOSHIZAKI			
Modelnavn			PREMIER F 4 A DL DL DR DR	PREMIER K/M 4 A DL DL DR DR	PREMIER K/M 4 A 2D 2D 2D 2D	PREMIER K/M 4 A 3D 3D 3D 3D
Tilsigtet anvendelse			Storage	Storage	Storage	Storage
Køledriftstemperatur				X	X	X
Frysedriftstemperatur			X			
Skab med flere funktioner						
Lodret skab						
Kølebord			X	X	X	X
Parameter	Symbol	Unit				
Energieffektivitetsklasse	EEC	-	C	A	A	A
Energieffektivitetsindeks	EEL	-	44,77	17,37	21,87	22,79
24 timers energiforbrug	E24h	kWh	5,67	1,319	1,612	1,612
Årligt energiforbrug	AEC	kWh	2070	481	588	588
Nettovolumen for rum 1	Vn1	litre	96	96	88	77,5
Nettovolumen for rum 2	Vn2	litre	96	96	88	77,5
Nettovolumen for rum 3	Vn3	litre	96	96	88	77,5
Nettovolumen for rum 4	Vn4	litre	96	96	88	77,5
Nettovolumen i alt	VnT	litre	384	384	352	310
Klimaklasse	CC		4	5	4	4
Kølemiddel			R290	R290	R290	R290
Belastning		kg	0.055	0.065	0.065	0.065
GWP			3	3	3	3
CO2-ækvivalent		CO ₂	0,165	0,195	0,195	0,195
Robust. Dette apparat er beregnet til brug i omgivelsestemperaturer op til 40 °C				X		
Kontaktoplysninger:			HOSHIZAKI EUROPE B.V.			
			Address: Burgemeester Stramanweg 101 1101 AA Amsterdam, The Netherlands Tel.: +31 (0)20 691 84 99 - http://hoshizaki.europe.com/			

HOSHIZAKI

PREMIER UNDERCOUNTER



II. BETJENINGSANVISNINGER

ELEKTRICITET

Før du slutter produktet til strøm, skal du kontrollere, at den angivne strømforsyning på mærkaten med produktbeskrivelsen svarer til den lokale netspænding.

Mærkaten med produktbeskrivelsen med den specificerede strømforsyning findes på indersiden af skabet øverst til venstre.

Installation af produktet må kun udføres af kvalificeret og uddannet servicepersonale i henhold til specifikationerne i denne vejledning.

Elektrisk sikkerhed for dette skab er kun gyldig, hvis det er jordet i overensstemmelse med gældende, lokale love og regler.

Jording af produktet er altid påkrævet.

Producenten påtager sig intet ansvar for skader, der opstår som følge af forkert jording.

Overhold alle elektricitetskrav i de lokale regler for elektricitet. Produktets elstik og stikkontakt skal have den korrekte jordforbindelse. Få om nødvendigt en kvalificeret elektriker til at løse opgaven.

GENERELLE, INDLEDENDE KONTROLLER

Kontroller, at skabet står på et plant underlag og står lodret. Om nødvendigt kan skabets justerbare fødder bruges til at opnå dette. Alle skabets fødder skal være i kontakt med jorden. Det er nødvendigt, for at skabslågen kan fungere korrekt.

Placer ikke skabet ved siden af varmegenererende enheder såsom ovne, grill- og fritureenheder. Må ikke udsættes for direkte sollys. Varme, der kan udstråles fra vægge eller gulve, skal isoleres med passende isoleringsmateriale. Skabet skal placeres så langt som muligt fra varmekilder.

Hvis skabet flyttes, må det først startes efter tre timer. Plastbeskyttelse eller tape skal fjernes fra ydersiderne.

Kontroller, at skabet er placeret, så tilstrækkelig frisk luft kan strømme til/fra kølekredsløbet og rundt om skabets overflader. Kontroller, at der er mindst 500 mm fri plads over skabet.

Hvis to køleskabe eller fryseskabe skal placeres side om side, skal der være et mellemrum på mindst 50 mm mellem dem.

Undgå at blokere udluftningshuller.

INDLEDENDE ELEKTRICITETSKONTROLLER

- a. Kontroller, at stikkontaktens netspænding og frekvens stemmer overens med oplysningerne på mærkaten med produktbeskrivelsen.
- b. Skabet er sluttet til en stikkontakt med en 13-16 ampere sikring som seriel forbindelse.
- c. Sluk for netsikringen, der er sluttet til strømkablet.
- d. Kontroller, at stikket på skabet er egnet til brug med den tilgængelige stikkontakt, og at de passer sammen.

PREMIER UNDERCOUNTER

FØRSTE IBRUGTAGNING OG KONTROLLER

Efter at ovenstående kontroller er gennemført, kan skabet tages i brug. Tænd og sluk skabet med ON/OFF-kontakten.

Når skabet er tændt, begynder kompressoren at køre. Kompressoren kører, indtil den fabriksindstillede temperatur er nået. Madvarer bør ikke placeres i skabet, før temperaturindstillingen er justeret, så den passer til de fødevarer, der skal køles.

Ny temperaturindstilling kan foretages via styreenheden som beskrevet i denne vejledning.



VIGTIGT

- Lad produktet køle af til den indstillede temperatur, før der lægges madvarer i skabet.
- Overskrid aldrig den maksimale kapacitet. Den maksimale hyldekapacitet er en jævnt fordelt belastning på 40 kg for hylder i opretstående skabe og 20 kg for hylder og skuffer i køleborde.
- Se afsnittet "Generelle, indledende kontroller" i denne vejledning for information om mængden af plads, der kræves til god luftventilation omkring produktet.
- Opbevar ikke eksplosive stoffer såsom spraydåser med brændbar drivgas i produktet.
- **Ved 1/3 skuffe kan Beholderlåg med tætningsudstyr ikke anvendes.**

ADVARSEL:

- Undgå til enhver tid at blokere ventilationsåbninger på produktet.
- Brug ikke mekaniske anordninger eller andre midler til at fremskynde afrimningsprocessen ud over dem, der er anbefalet af producenten.
- Kølekredsløbet må ikke beskadiges.
- Brug ikke elektriske apparater inde i skabet.
- Vær opmærksom på ikke at beskadige strømkabel, ledninger eller komponenter.

OPBEVARINGSBETINGELSER OG YDEEVNE

Korrekte opbevaringsforhold er ikke kun altafgørende for fødevarerhygiejne og sikkerhed, men forbedrer anvendelseskvaliteten og reducerer energiforbruget. Den bedste ydeevne opnås, hvis følgende tips og retningslinjer overholdes: Opbevar alle madvarer på hylderne, og placer aldrig madvarer på gulvet i skabet. Madvarer skal placeres i skabet på en sådan måde, at der er god luftgennemstrømning hele vejen rundt, så der er plads mellem emnerne og produktets vægge. Om nødvendigt kan hyldeafstanden justeres i overensstemmelse hermed.

PREMIER UNDERCOUNTER

III. STYREPANEL



➤ FRONTPANELFUNKTIONER

For at låse frontpaneltasterne skal AUX (3) og On/Stand By (1) holdes nede i 2 sekunder: Teksten "Loc" vises på skærmen, når tasterne er låst, hvis de ikke er låst, vises teksten "UnL" på skærmen.

1) Når du holder **ON/STAND BY** nede i 4 sekunder, åbner eller lukker enheden. (On/Off)

2) **MANUEL AFRIMNING**. Hvis knappen holdes nede i 4 sekunder, starter manuel afrimning. Hvis ekstra køling er aktiveret, og fordampertemperaturen ikke er passende, starter manuel afrimning ikke.

3) **NED**-tasten: Rul ned i menuen, eller reducer værdien. Hvis den holdes nede i 4 sekunder, aktiveres superkøling. Når ekstra kølefunktion er aktiveret, kan den indstillede temperatur reduceres. Klokkeslæt og temperatur fastsættes ved hjælp af parametrene. Når ekstra kølefunktion er aktiveret, afrimer enheden aldrig.

5) **OP**-tasten: Rul op i menuen, eller øg værdien. Hvis den holdes nede i 4 sekunder, aktiveres funktionen til procentdel af lav og høj relativ luftfugtighed. (For nogle modeller) står der "rhL" på skærmen (en funktion med lav procentdel af relativ luftfugtighed er aktiveret), eller der står "rhH" på skærmen (en funktion med høj procentdel af relativ luftfugtighed er aktiveret). Disse funktioner vises på skærmen i 10 sekunder. Hvis styring af fugtighed ikke er tilgængelig, vises "----" på skærmen i 1 sekund.

6) **SET**-tasten: Indtastnings- og ændringstast for justerbare værdier.

➤ DRIFT

Driftstilstande vises nedenfor:

Status "On": (Enheden strømforsynes og er i drift).

"Stand-By"-status: (Enheden er slukket, men strømforsynes stadig).

"Off"-status: For at slukke enheden skal stikket tages ud af stikkontakten, eller der skal slukkes på hovedafbryderen.

HOSHIZAKI

PREMIER UNDERCOUNTER



IV. VEDLIGEHOELDESESANVISNINGER

Enheden skal rengøres regelmæssigt. Intervallerne afhænger af brugen og niveauet af tilsmudsning (mindst en gang om året).



Før du udfører nogen form for rengøring eller vedligeholdelse, skal du tage stikket ud af enheden



Rør ikke maskinrummets dele, og gør dem ikke våde. Dette kan resultere i fejl eller sammenbrud.



Plastdelene må ikke rengøres ved temperaturer over 40 °C og tåler ikke opvaskemaskine.

Inderside og yderside af skab og hylder



Rengør indvendigt og udvendigt mindst en gang om ugen af hensyn til hygiejnisk brug.



Rengør indersiden og ydersiden af skabet med en blød klud dyppet i koldt eller varmt vand med den korrekte mængde neutralt rengøringsmiddel og vredet tør. Brug ikke en vandstråle til at rengøre maskinrummet.



Andre kemiske midler end neutralt rengøringsmiddel kan forårsage skader på de indvendige og udvendige overflader.



Eventuelt resterende rengøringsmiddel vil beskadige metal- eller plastoverflader. Brug en blød klud fugtet med varmt vand til at tørre det af.



Brug ikke følgende genstande, da de kan beskadige malede overflader eller plastoverflader:

- Polerpulver, sprit, fortynder, benzen, surt eller alkalisk rengøringsmiddel, varmt vand, petroleum, sæbepulver, metalskurebørste eller børste osv. Især rengøringsmiddel til fjernelse af fedt fra ventilator eller mikrobølgeovn

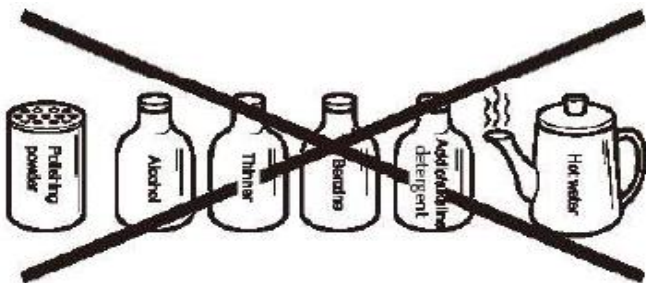

Bemærk: **Visse andre opløsninger end ovenstående kan også beskadige malede overflader eller plastoverflader. Stop øjeblikkeligt med at bruge sådanne opløsninger, hvis de forårsager problemer!**



Dørpakningen og dens kontaktflade bliver let snavset. Rengør alle overflader på disse dele grundigt. Madrester forkorter skabets levetid.



Brug en klud til at tørre alt vand inde i skabet af.

HOSHIZAKI

PREMIER UNDERCOUNTER



Kondensator



Brug en støvsuger eller en blød børste til at fjerne støv og pletter fra kondensatoren.



Advarsel: **Hvis brugere rengør kondensatoren med en hård børste, som f.eks. opvaskebørste, kan kondensatorens belægning skade af.**

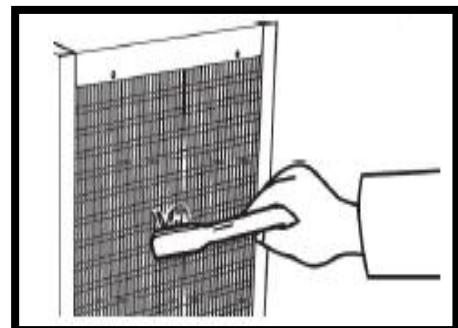

Luftfilter



For at forhindre deformation må luftfilteret ikke vaskes med varmt vand over 40 °C



Luftfiltre af plastnet fjerner snavs og støv fra luften og forhindrer, at kondensatoren tilstoppes. Hvis filtrene tilstoppes, reduceres køleskabets/fryseskabets ydeevne.



Tjek filtrene mindst to gange om måneden. Når de er tilstoppede, eller når temperaturregulatoren viser "cH", skal filtrene vaskes med varmt vand og et neutralt rengøringsmiddel. Betjen ikke enheden med luftfiltrene fjernet, da kondensatoren ellers bliver tilstoppet, hvilket resulterer i fejl.

- 1) Åbn frontpanelet, og fjern luftfilteret. For at undgå skader må du ikke røre kondensatorfinnerne direkte.
- 2) Vask luftfilteret omhyggeligt med koldt eller varmt vand med den rette mængde neutralt rengøringsmiddel. Skyl og tør luftfilteret omhyggeligt.
- 3) For at montere luftfilteret igen skal de to tapper sættes ind i varmeveksleren eller finnerne i kondensatoren, og luftfilteret fastgøres tæt over kondensatoren.

HOSHIZAKI

PREMIER UNDERCOUNTER

V. TEKNISKE OPLYSNINGER



ENHEDERNES STØRRELSE

PREMIER K-M-F 2 A DL DR L

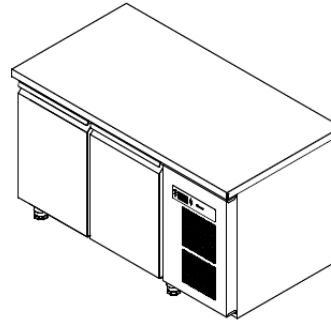
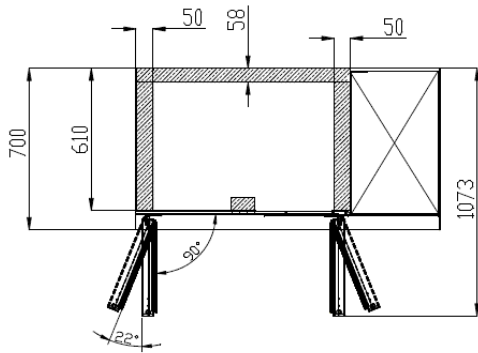
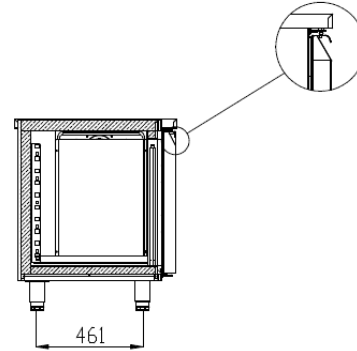
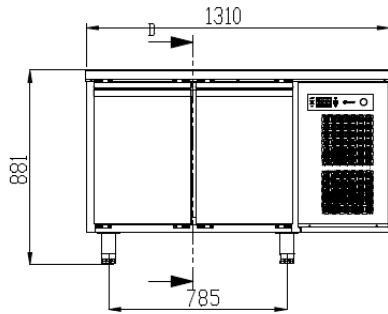

PREMIER K-M-F 2 A DL DR C

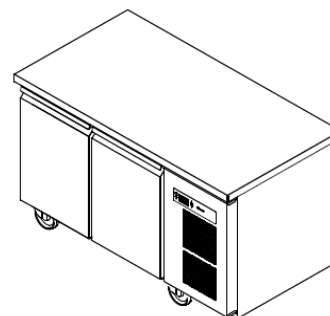
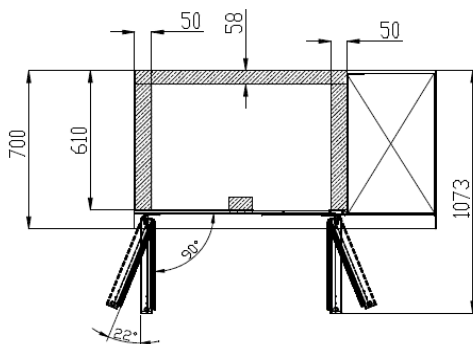
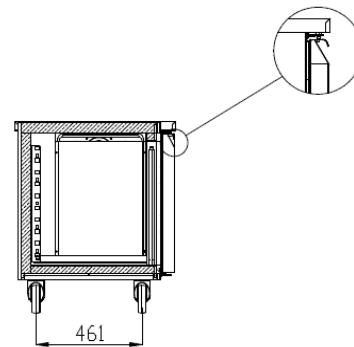
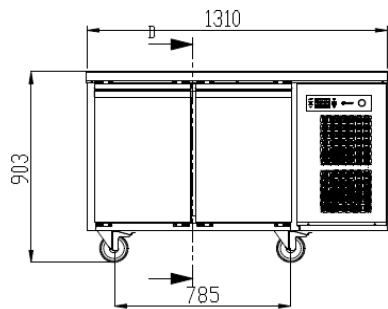

HOSHIZAKI

PREMIER UNDERCOUNTER



PREMIER K-M 2 A 2D 2D L

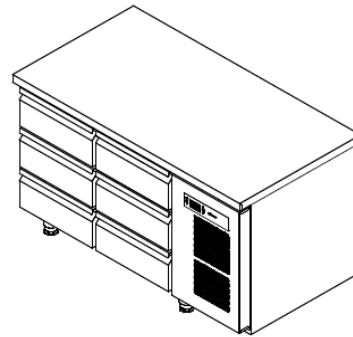
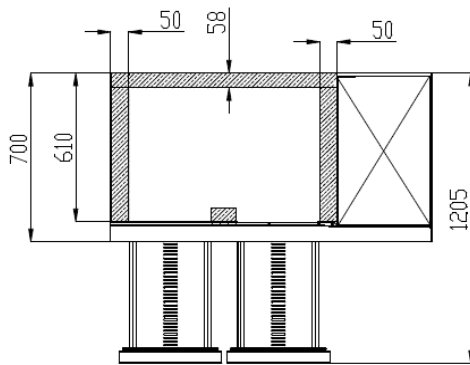
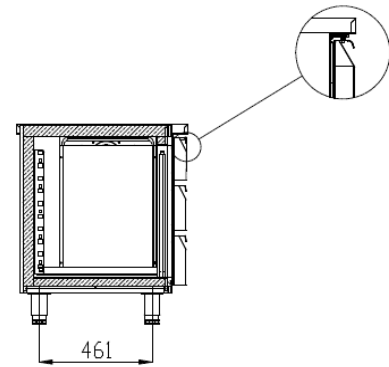
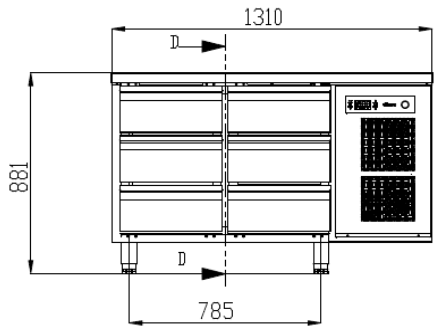

PREMIER K-M 2 A 2D 2D C

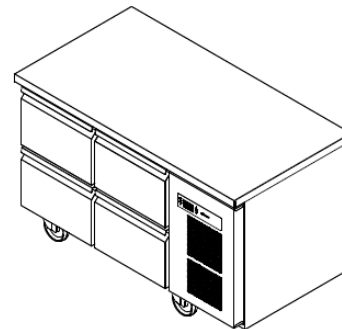
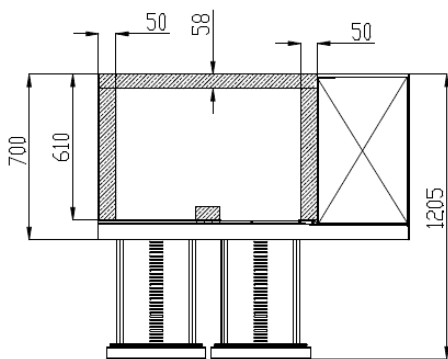
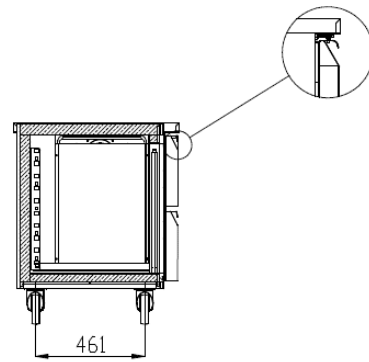
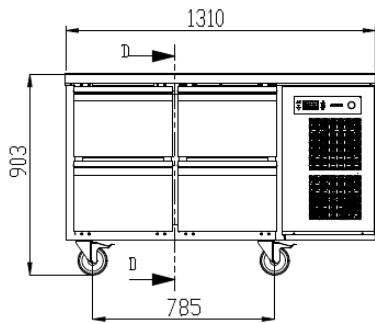

HOSHIZAKI

PREMIER UNDERCOUNTER



PREMIER K-M 2 A 3D 3D L

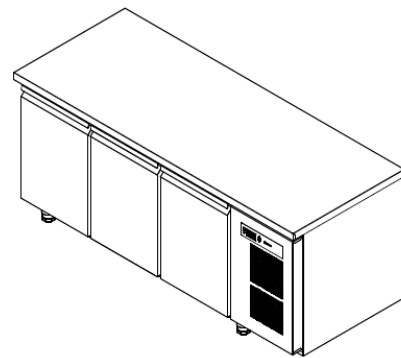
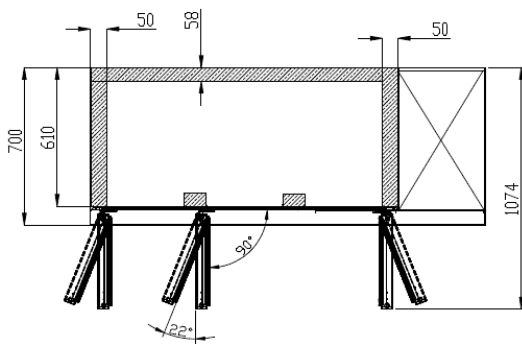
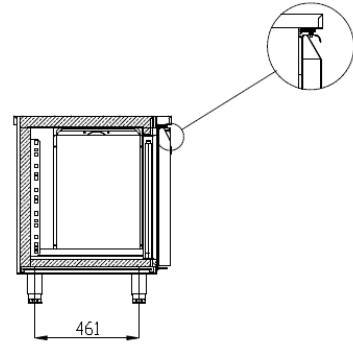
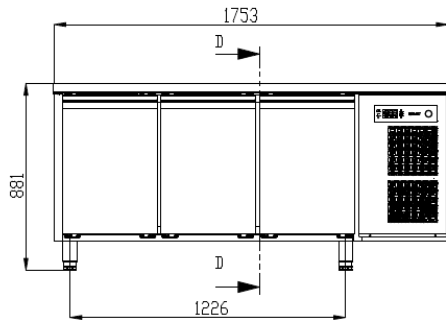

PREMIER K-M 2 A 3D 3D C

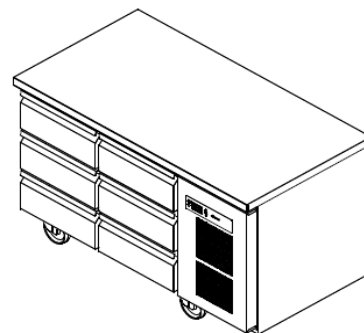
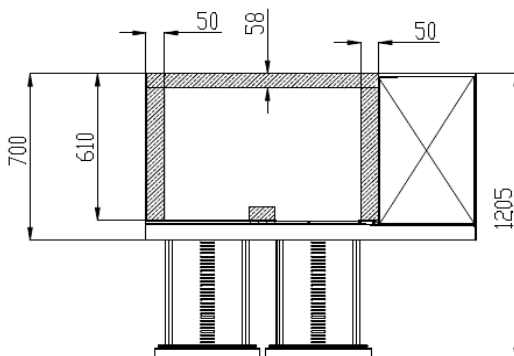
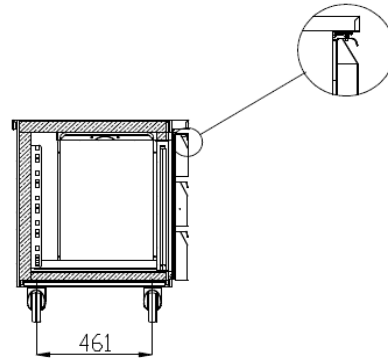
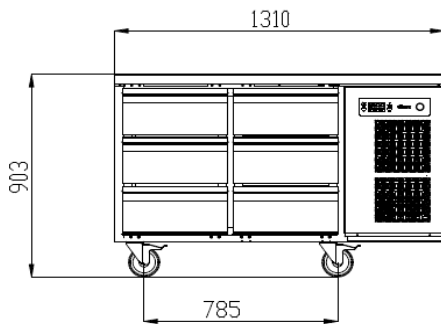

HOSHIZAKI

PREMIER UNDERCOUNTER

PREMIER K-M-F 3 A DL DR DR L

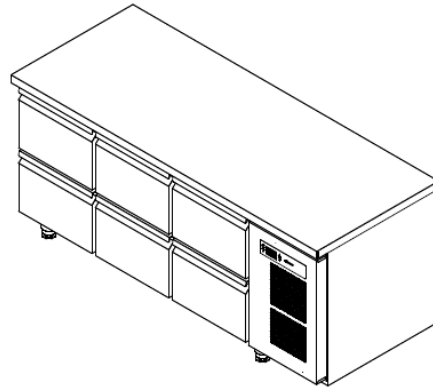
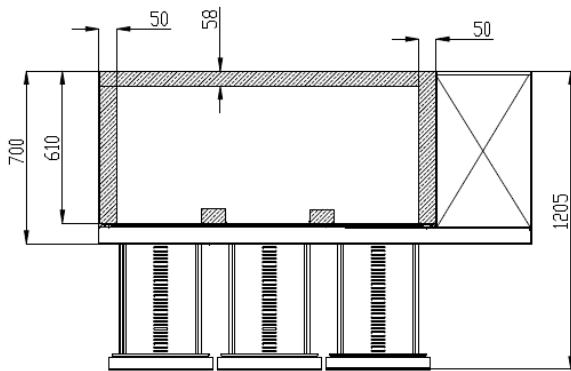
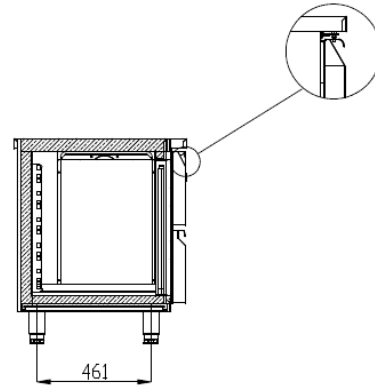
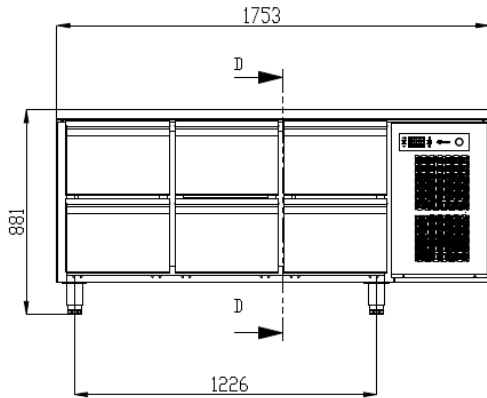

PREMIER K-M-F 3 A DL DR DR C

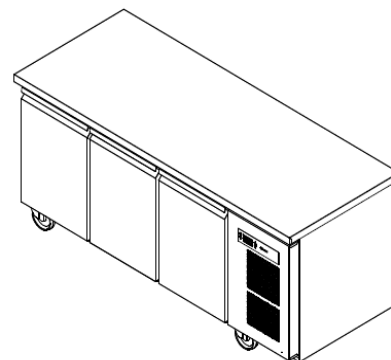
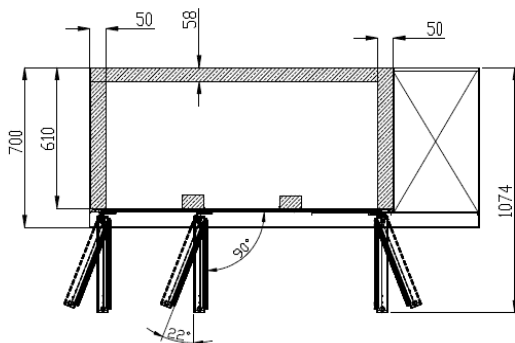
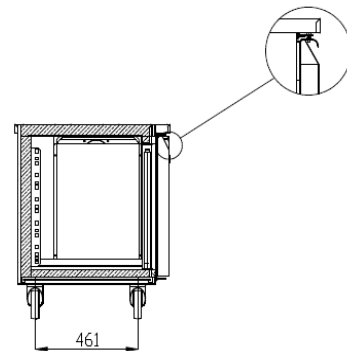
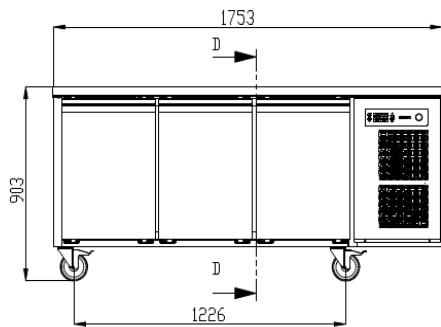

HOSHIZAKI

PREMIER UNDERCOUNTER



PREMIER K-M 3 A 2D 2D 2D L

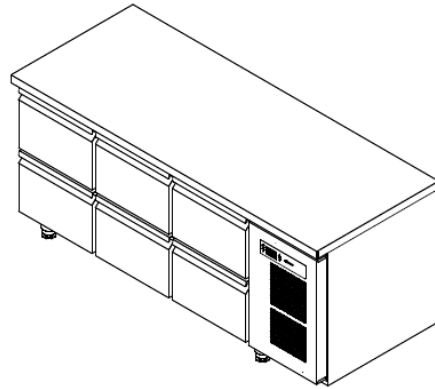
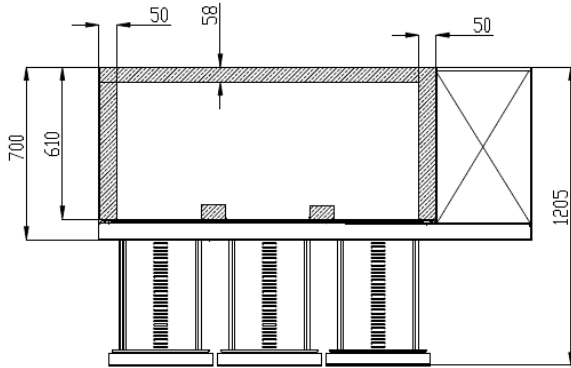
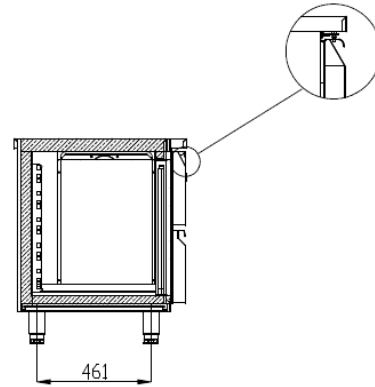
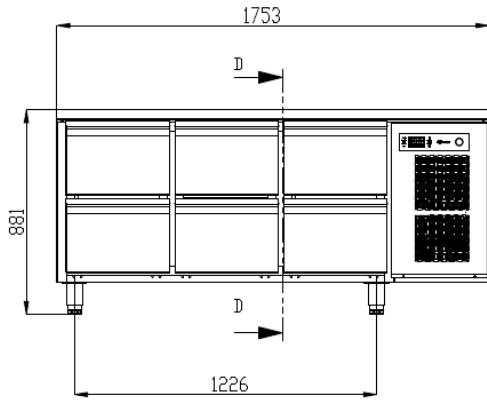

PREMIER K-M 3 A 2D 2D 2D C

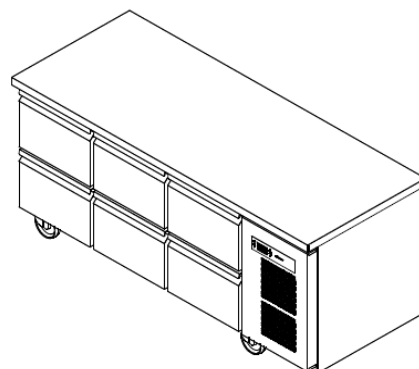
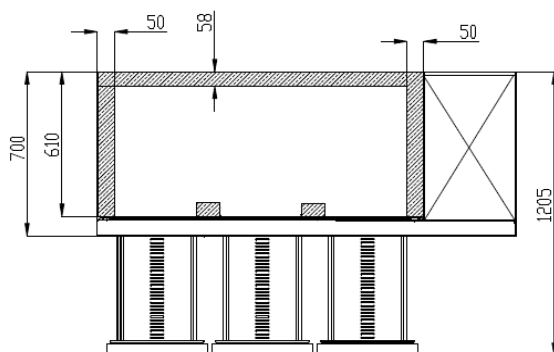
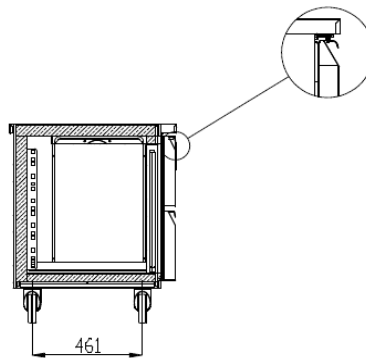
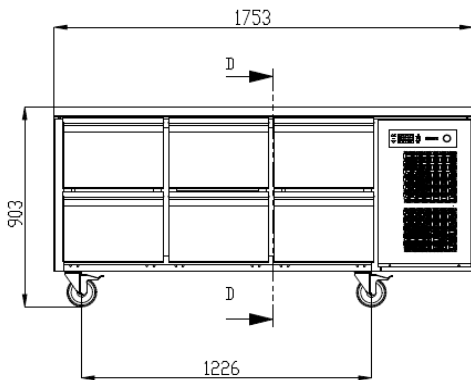

HOSHIZAKI

PREMIER UNDERCOUNTER



PREMIER K-M 3 A 3D 3D 3D 3 L

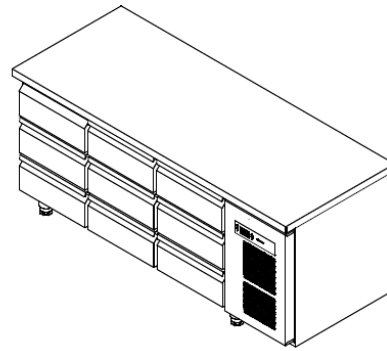
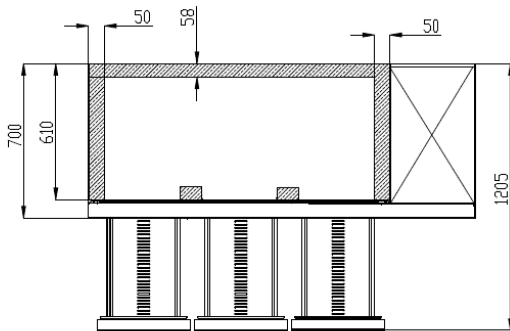
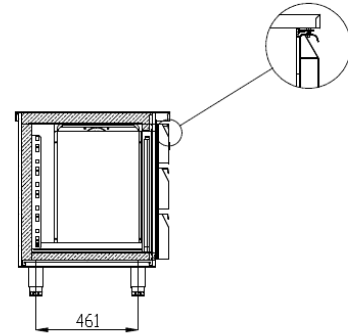
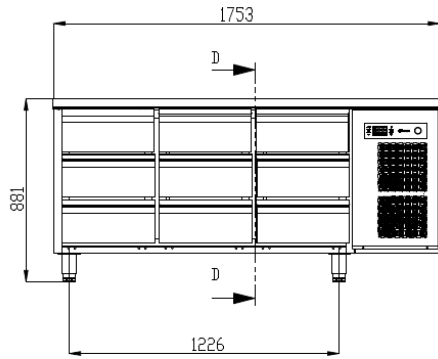

PREMIER K-M 3 A 3D 3D 3D C

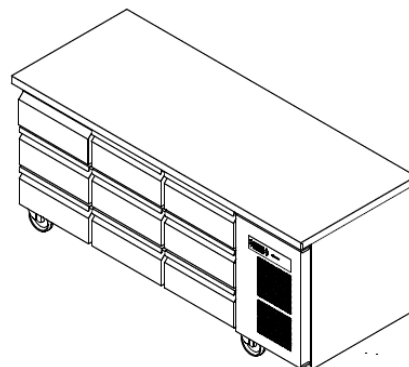
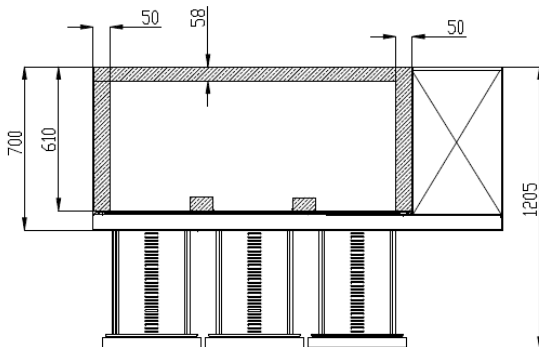
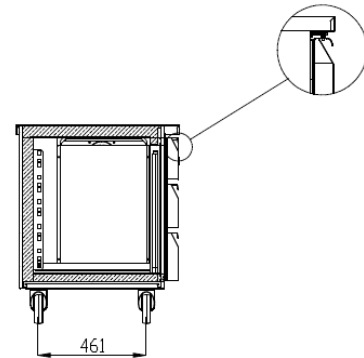
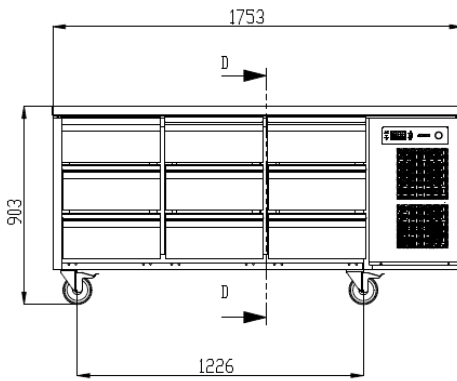

HOSHIZAKI

PREMIER UNDERCOUNTER

PREMIER K-M-F 4 A DL DL DR DR L

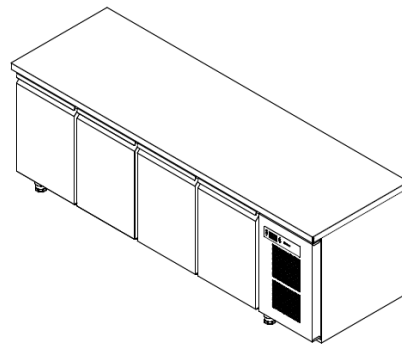
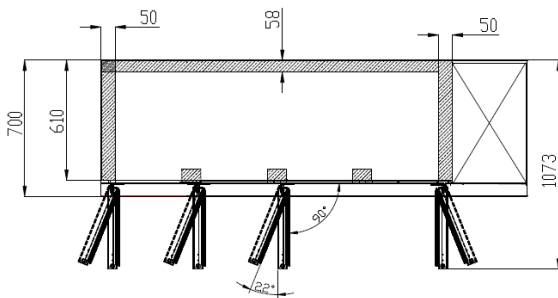
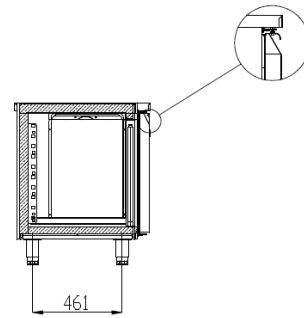
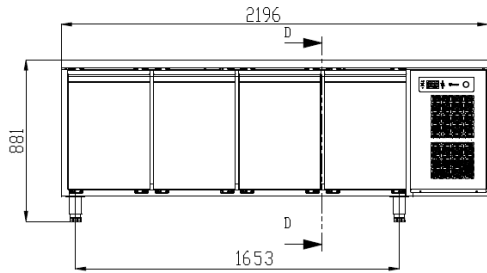

PREMIER K-M-F 4 A DL DL DR DR C

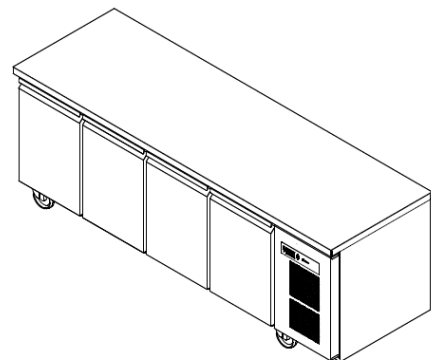
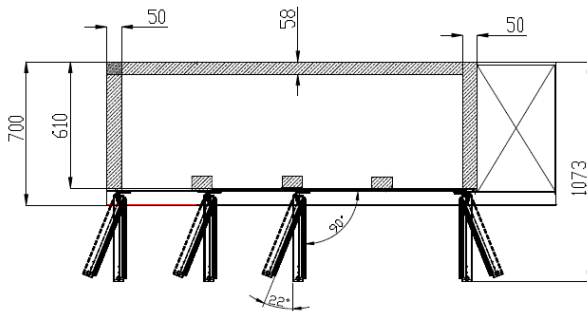
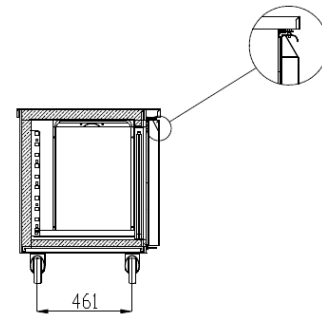
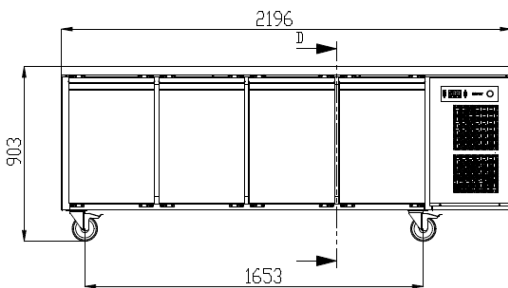

HOSHIZAKI

PREMIER UNDERCOUNTER



PREMIER K-M 4 A 2D 2D 2D 2D L

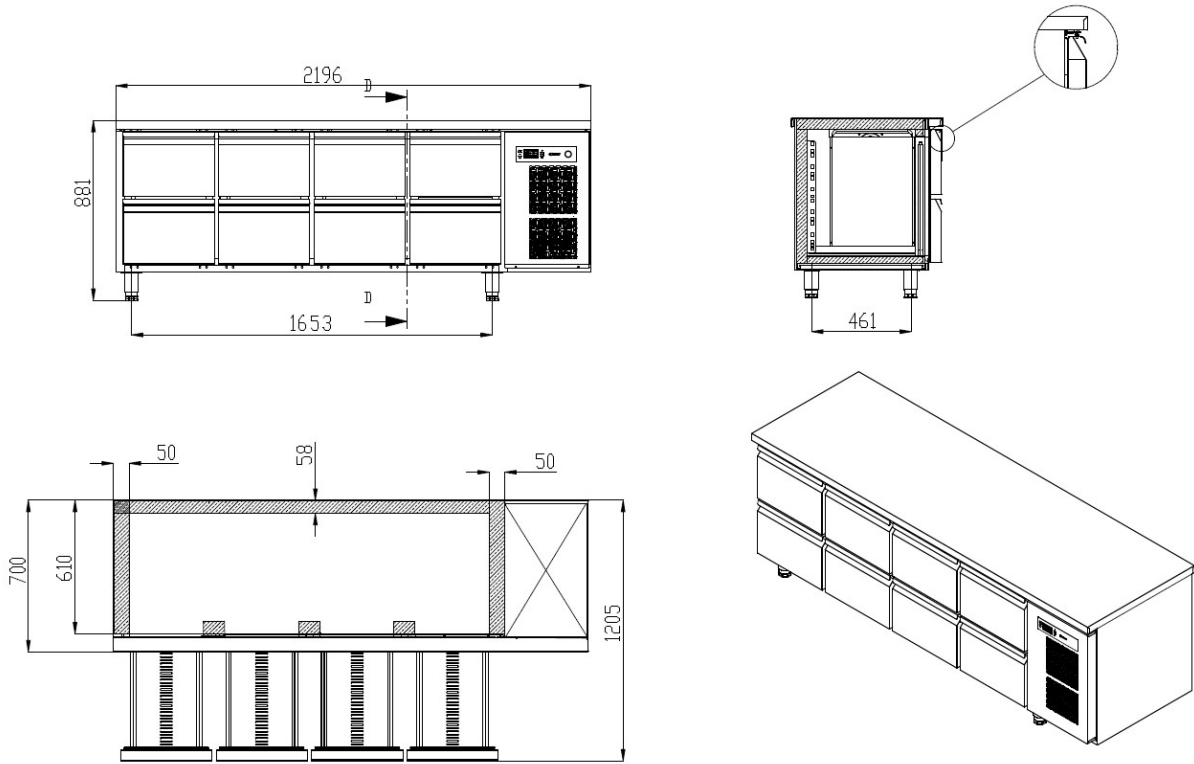

PREMIER K-M 4 A 2D 2D 2D 2D C

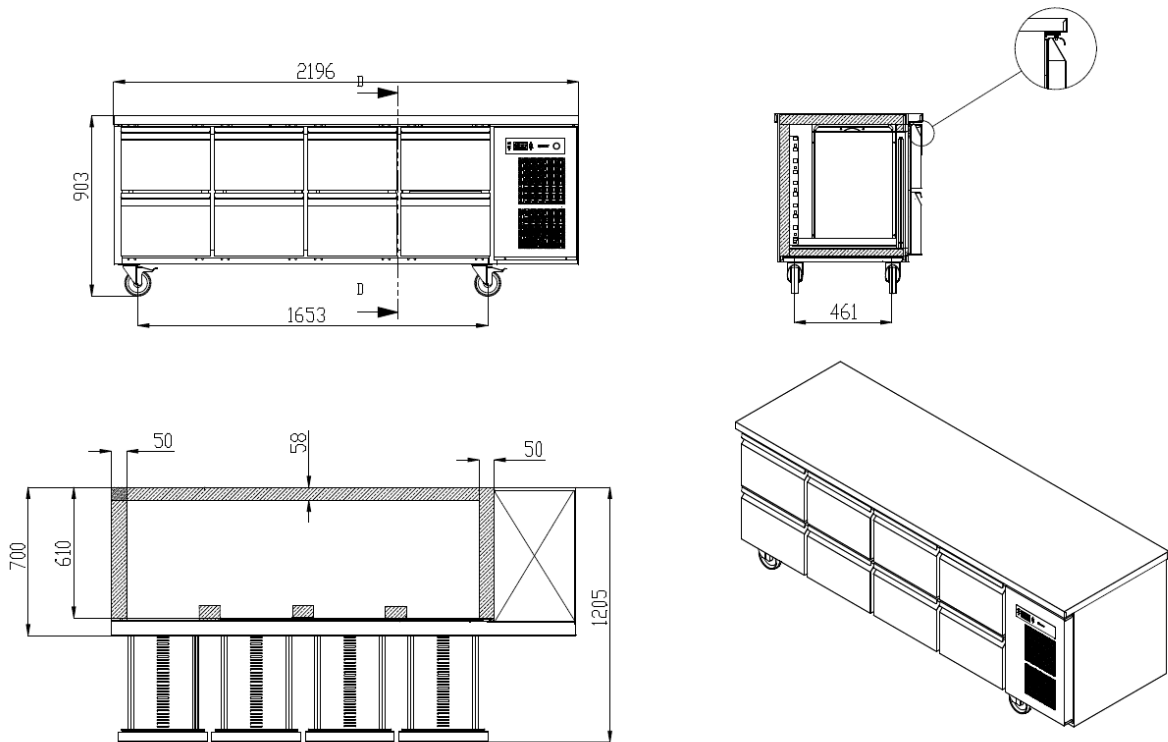

HOSHIZAKI

PREMIER UNDERCOUNTER



PREMIER K-M 4 A 3D 3D 3D 3D L

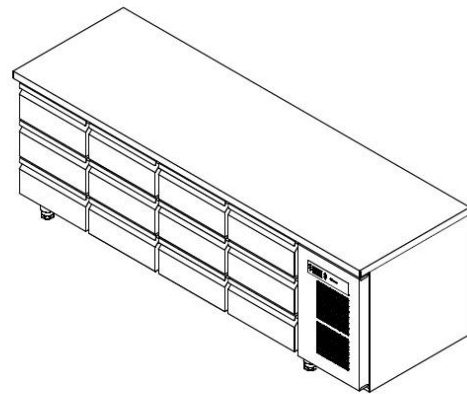
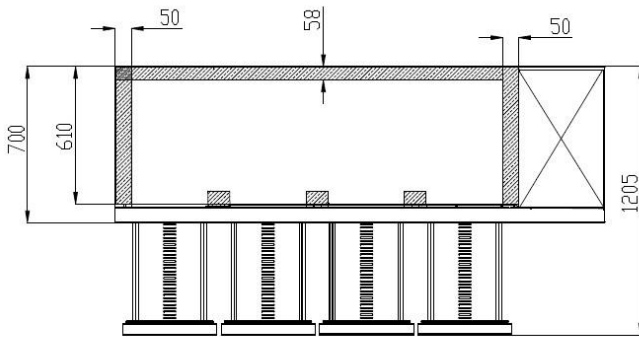
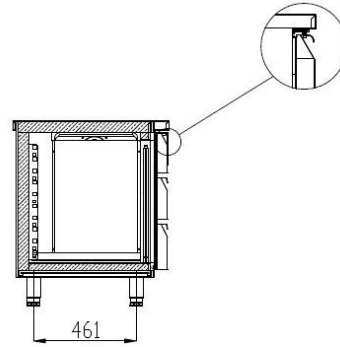
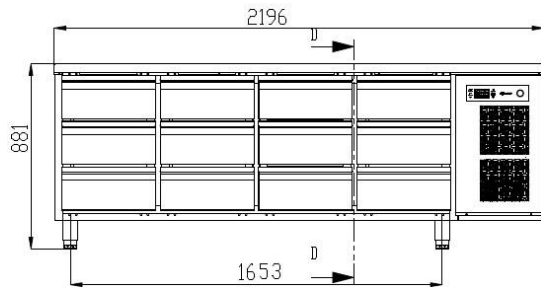

PREMIER K-M 4 A 3D 3D 3D 3D C

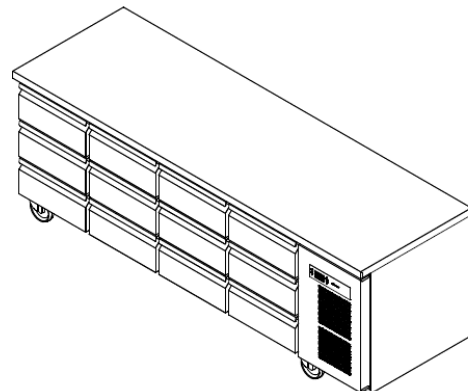
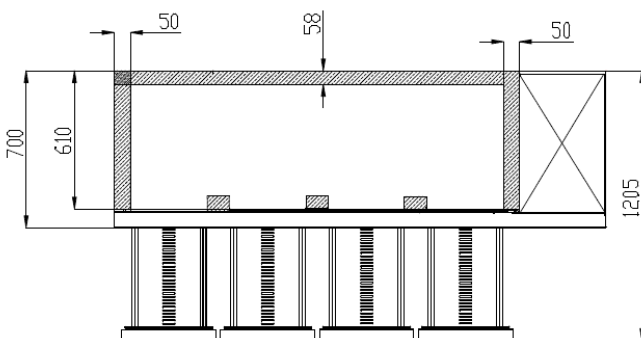
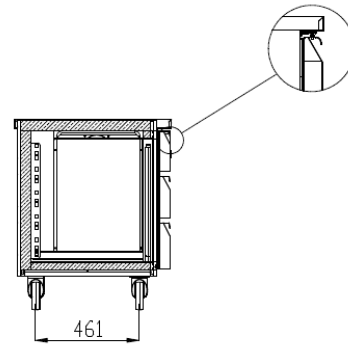
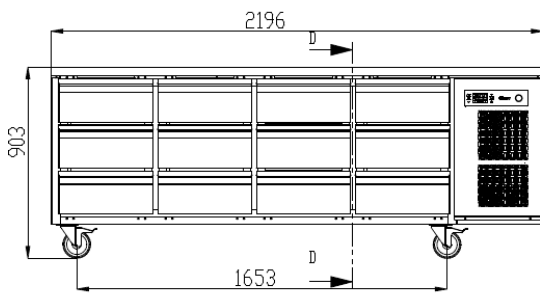

HOSHIZAKI

PREMIER UNDERCOUNTER



VI. KØLEDIAGRAM - ELEKTRISK LEDNINGSDIAGRAM

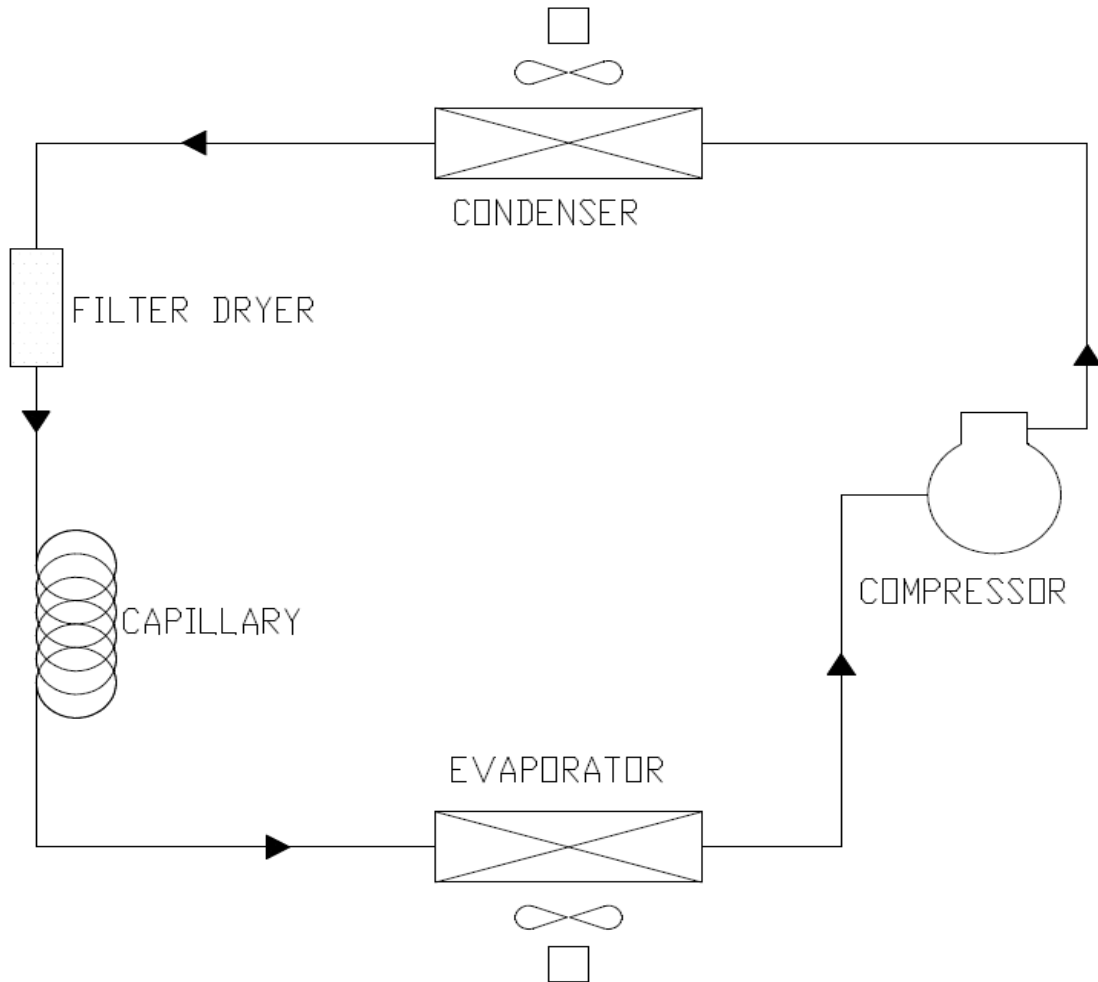

HOSHIZAKI

PREMIER UNDERCOUNTER



VII. SERVICEDIAGNOSE

Tabellen nedenfor viser forskellige problemer, som du kan støde på. Hvis en alarmkode vises, er der opstået en funktionsfejl. Afhjælp alle mulige årsager, før du nulstiller skabet. Potentielle årsager og løsninger er angivet nedenfor.

Hvis en fejlkode fortsætter, efter du har udført nedenstående kontroller, skal du kontakte en autoriseret tekniker. Fejlmeddelelsestypen skal fastlægges. Produktdetaljer inklusive serienummer findes på produktets typeskilt.

PROBLEM	MULIG ÅRSAG	AFHJÆLPNING	
Skabet virker ikke	Der er ingen strømforsyning til skabet	Kontroller, at stikket og kablet er uden fejl	
Kompressoren stopper sjældent med at køre	Den omgivende temperatur er for høj	Ventilationen skal forbedres	
	Kondensator eller kondensatorfilter er blokeret	Kontroller og rengør kondensatorfilteret regelmæssigt	
	Lågepakninger er ikke tilstrækkeligt tætte	Tilkald en autoriseret tekniker for at udskifte pakninger	
	Fordamperen er iset til		Stil ikke varme fødevarer i skabet
			Anbring ikke madvarer med højt vandindhold inde i skabet, medmindre de opbevares i forseglede beholdere
			Start en manuel afrimningscyklus
Fordamperventilator/-ventilatorer er defekte	Tilkald en autoriseret tekniker for at udskifte ventilatoren/ventilatorerne		
Vand fra kondensatorvandsbakken løber over	Hyppig placering af varme fødevarer i skabet	Stil ikke varme fødevarer i skabet Placer kun madvarer med højt vandindhold i forseglede beholdere i skabet	
	Hyppig åbning af låge eller skuffer	Kontroller, om skabets specifikationer bekræfter, at det er egnet til den aktuelle brug	
Skabstemperaturen er høj	Kondensatoren er blokeret af snavs og støv	Kontroller og rengør kondensatorfilteret regelmæssigt	
	Luftstrømmen i skabet er blokeret	Fjern madvarer, der blokerer for luftstrømmen	
	Luft udefra kommer ind i skabet	Kontroller, at lågen er lukket	
		Tjek for skader på lågen og skuffepakningerne	
Fordamperen er iset til	Kontakt en autoriseret tekniker		
		Start en manuel afrimningscyklus	

HOSHIZAKI

PREMIER UNDERCOUNTER



VIII. AFMONTERING OG UDSKIFTNING

BORTSKAFFELSE AF SKABET

- Kølegassen i skabet kan identificeres på typeskiltet.
- Skabet er fremstillet af genanvendelige materialer i henhold til EU-regler. Derfor skal skabet, når dets levetid er slut, afleveres til en relevant genbrugsstation til bortskaffelse.
- Bortskaf ikke skabet som metal eller husholdningsaffald.
- Komprimer ikke køleanlæggets kølekredsløb.



VIGTIGT

Overhold lokale vedtægter og regler ved bortskaffelse af skabet.

HOSHIZAKI

PREMIER UNDERCOUNTER



Alle rettigheder forbeholdes. Hoshizaki forbeholder sig retten til at ændre alle funktioner og oplysninger denne vejledning.

Kontaktoplysninger

Hovedkvarter

Hoshizaki Europe B.V – All other countries in Europe and Africa

TEL: +31 (0)20 6918499

sales@hoshizaki.nl -- <http://hoshizaki-europe.com/>

Filialer

Hoshizaki UK - UK, Ireland

TEL: +44 (0)845 456 05 85

uksales@hoshizaki.co.uk

Hoshizaki Deutschland - Germany, Switzerland, Austria

TEL: +49 (0)5121 697370

vertrieb@hoshizaki.de

Hoshizaki Benelux - Netherlands, Belgium, Luxembourg

TEL: +31 (0)85 0188370

info@hoshizaki.nl

Hoshizaki France - France

TEL: +33 (0)1 48 63 93 80

info@hoshizaki.fr

Hoshizaki Iberia - Spain, Portugal

TEL: +34 (0)93 478 09 52

info@hoshizaki.es

Hoshizaki Denmark - Denmark

TEL: +45 89 88 53 50

salg@hoshizaki.dk

Hoshizaki Norway - Norge

TEL: +47 22 88 17 50

salg@hoshizaki.no

Hoshizaki Sweden - Sverige

TEL: +46 108 84 87 47

OrderSE@hoshizaki.dk

Hoshizaki Italia – Italia

TEL: +39 348 3022156

commerciale@hoshizaki.it

HOSHIZAKI

PREMIER UNDERCOUNTER



PREMIER UNDERCOUNTER

FRIGORIFERI E CONGELATORI MANUALE DI INSTALLAZIONE, USO E MANUTENZIONE



I. INFORMAZIONI GENERALI	158
II. ISTRUZIONI PER L'USO	163
III. PANNELLO DI CONTROLLO	165
IV. ISTRUZIONI PER LA MANUTENZIONE	166
V. INFORMAZIONI TECNICHE	168
VI. SCHEMA DI RAFFREDDAMENTO - SCHEMA ELETTRICO	177
VII. RISOLUZIONE DEI PROBLEMI	179
VIII. RIMOZIONE E SOSTITUZIONE	180

Dettagli del contatto:

HOSHIZAKI EUROPE B.V.

Indirizzo: Burgemeester Stramanweg 101 1101 AA Amsterdam, Paesi Bassi

Tel: +31 (0)20 691 8499 <http://hoshizaki-europe.com/>



PREMIER UNDERCOUNTER

I. INFORMAZIONI GENERALI

ETICHETTA DESCRITTIVA DEL PRODOTTO

1 - Codice prodotto
2 - Descrizione prodotto
3 - Modello
4 - Refrigerante (GWP)
5 - CO ₂ equivalente
6 - Protezione IP
7 - Classe climatica
8 - Data di produzione
9 - Potenza totale / Corrente / Potenza lampada
10 - Tensione - Frequenza
11 - Elemento riscaldante
12 - Pressione impianto
13 - Agente gonfiante
14 - Numero di serie

PRODUCT NUMBER	1
	
PRODUCT DESCRIPTION	2
MODEL	3
REFRIGERANT	4
CO ₂ EQUIVALENT	5
IP PROTECTION	6
CLIMATE CLASS	7
PRODUCTION DATE	8
TOTAL POWER / CURRENT / LAMP POWER	9
VOLTAGE - FREQUENCY	10
HEATING ELEMENT	11
SYSTEM PRESSURE	12
BLOWING AGENT	13

S/N: 14



HOSHIZAKI EUROPE B.V. Burgemeester Stramanweg 101 1101 AA
Amsterdam, The Netherlands



MODALITÀ D'USO

- Questo prodotto è idoneo per l'uso solo in ambienti interni e unicamente allo scopo di conservare alimenti e bevande. Unità di conservazione progettate per mantenere il prodotto già alla temperatura del frigorifero/congelatore.
- Il produttore non potrà essere ritenuto responsabile di eventuali danni derivanti da usi diversi da quelli indicati nel presente manuale.
- Accertarsi che gli alimenti conservati in questo armadio frigo non vengano mai a contatto con il corpo dell'armadio stesso.
- Tutti gli alimenti devono essere avvolti completamente. Per evitare la contaminazione e la corrosione dei componenti interni, tutto il prodotto dovrebbe essere imballato o conservato in contenitori sigillati.
- Non riporre alimenti o liquidi caldi in questo armadio frigo.
- Le bevande contenute in cartoni o bottiglie di vetro non devono essere conservate a temperature inferiori a 0°C (punto di congelamento). Le lattine e le bottiglie di vetro potrebbero esplodere a causa dell'espansione. I contenitori provvisti di coperchio non devono essere riempiti completamente: lasciare un po' di spazio libero per consentire l'espansione.
- Questo armadio frigo è dotato di una funzione di sbrinamento automatico. Lo sbrinamento può essere eseguito anche manualmente. Lo sbrinamento manuale non richiede lo spegnimento dell'armadio frigo per un periodo prolungato ma può essere eseguito mediante il controller. Non utilizzare mai la forza o utensili manuali per sbrinare questo armadio frigo; eventuali danni derivanti da tali azioni potrebbero essere irreparabili.
- Non utilizzare mezzi meccanici o alternativi per eseguire lo sbrinamento.
- La macchina non deve essere utilizzata da persone (inclusi i bambini) con capacità fisiche, sensoriali e mentali ridotte o prive dell'esperienza e della conoscenza necessarie, tranne nei casi in cui siano fornite supervisione o istruzioni.
- I bambini devono essere sorvegliati affinché non giochino con la macchina.

PREMIER UNDERCOUNTER

- La pulizia e la manutenzione da parte dell'utente non devono essere effettuate da bambini non sorvegliati.
- La macchina può essere utilizzata da persone (inclusi i bambini di età superiore agli 8 anni) con capacità fisiche, sensoriali e mentali ridotte o prive dell'esperienza e della conoscenza necessarie, nel caso in cui siano fornite la supervisione o le istruzioni relative all'utilizzo della macchina in modo sicuro e ne vengano compresi i rischi.
- Qualsiasi modifica elettrica o meccanica apportata all'armadio frigo ne annulla la garanzia. La garanzia risulta nulla anche in caso di modifiche effettuate da tecnici non autorizzati e modifiche diverse da quelle descritte nel presente manuale. Il produttore non potrà essere ritenuto responsabile dei danni derivanti da tali modifiche.

CLASSE CLIMATICA

L'armadio frigo è stato progettato per funzionare entro specifici valori di temperatura ambiente e umidità. Tali valori sono definiti nel sistema delle classi climatiche. Questi livelli non devono mai essere superati. La classe climatica per questo prodotto è indicata sull'etichetta descrittiva del prodotto stesso. Il frigorifero non è adatto all'uso a una temperatura ambiente inferiore a 16 °C.

Classe climatica	Temperatura ambiente e umidità
4	+30°C con umidità relativa al 55%
5	+40°C con umidità relativa al 40%

ACCETTAZIONE E CONTROLLI ALLA CONSEGNA

Questo armadio frigo viene avvolto in materiale da imballaggio protettivo per la spedizione. All'atto della consegna, verificare che il prodotto non presenti danni dovuti al trasporto e che il modello corrisponda a quello ordinato.



IMPORTANTE

Le operazioni descritte di seguito devono essere eseguite nel pieno rispetto delle leggi locali e delle norme di sicurezza. Durante l'uso del prodotto è necessario osservare le norme vigenti in materia di sicurezza.

TRASPORTO

Se il prodotto viene sollevato con un macchinario, è necessario verificare la capacità di sollevamento del macchinario prima di eseguire tale operazione.



IMPORTANTE

Se si utilizza un muletto per spostare il prodotto, accertarsi che la forca sia inserita nelle apposite fessure del pallet.

Durante lo spostamento è necessario prestare attenzione alla stabilità del prodotto. Se il centro di gravità non è in posizione corretta, il prodotto potrebbe ribaltarsi. Quando il prodotto viene abbassato con un muletto, accertarsi di eseguire l'operazione lentamente e con la dovuta cura.

Qualora sia necessario trasportare un armadio frigo verticale in posizione orizzontale, assicurarsi che sia stato in posizione verticale per almeno 2 ore prima di farlo funzionare. Si sconsiglia di trasportare un armadio frigo verticale in posizione orizzontale; eventuali danni derivanti da tale azione non sono coperti dalla garanzia.

PREMIER UNDERCOUNTER



ATTENZIONE

All'esterno dell'imballaggio sono riportate istruzioni utili per l'utente. Si raccomanda di attenersi alle istruzioni seguenti:

- Maneggiare il prodotto con cura.
- Mantenere il prodotto asciutto. Non appoggiare oggetti sulla parte superiore dell'armadio frigo!

RIMOZIONE DELL'IMBALLAGGIO

- Rimuovere il cartone e gli altri materiali di imballaggio.
- Sollevare l'armadio frigo per staccarlo e rimuoverlo dal pallet.
- Sistemare l'armadio frigo nella posizione desiderata, in modo che poggi sulla propria base.
- Verificare che il prodotto non presenti danni visibili.
- I materiali di imballaggio possono essere riciclati in base alle norme locali per il riciclo.
- Verificare che il codice e il numero di serie del prodotto corrispondano a quelli riportati nei documenti di spedizione.

Marchio			HOSHIZAKI			
Modello			PREMIER F 2 A DL DR	PREMIER K/M 2 A DL DR	PREMIER K/M 2 A 2D 2D	PREMIER K/M 2 A 3D 3D
Usato previsto			Storage	Storage	Storage	Storage
Temperatura di esercizio per la				X	X	X
Temperatura di esercizio per il			X			
Armadio frigo multiuso						
Armadio frigo verticale						
Banco refrigerato			X	X	X	X
Parametro	Symbol	Unit				
Classe di efficienza energetica	EEC	-	C	A+	A	A
Indice di efficienza energetica	EEl	-	40,26	13,9	17,42	17,85
Consumo energetico per 24 ore	E24h	kWh	3,862	0,869	1,069	1,069
Consumo energetico annuale	AEC	kWh	1410	317	390	390
Volume netto dello scomparto 1	Vn1	litre	96	96	88	77,5
Volume netto dello scomparto 2	Vn2	litre	96	96	88	77,5
Volume netto dello scomparto 3	Vn3	litre	-	-	-	-
Volume netto dello scomparto 4	Vn4	litre	-	-	-	-
Volume netto totale	VnT	litre	192	192	176	155
Classe climatica	CC		5	5	5	5
Refrigerante			R290	R600a	R600a	R600a
Carico		kg	0.055	0.07	0.07	0.07
GWP			3	3	3	3
CO2 equivalente		CO ₂	0,165	0,21	0,24	0,21
Usato intensivo; questo apparecchio è stato progettato per l'uso a una temperatura ambiente fino a 40°C.			X	X	X	X
Informazioni di contatto:			HOSHIZAKI EUROPE B.V.			
			Address: Burgemeester Stramanweg 101 1101 AA Amsterdam, The Netherlands Tel.: +31 (0)20 691 84 99 - http://hoshizaki.europe.com/			

HOSHIZAKI

PREMIER UNDERCOUNTER



Marchio			HOSHIZAKI			
Modello			PREMIER F 3 A DL DL DR	PREMIER K/M 3 A DL DL DR	PREMIER K/M 3 A 2D 2D 2D	PREMIER K/M 3 A 3D 3D 3D
Uso previsto			Storage	Storage	Storage	Storage
Temperatura di esercizio per la				X	X	X
Temperatura di esercizio per il			X			
Armadio frigo multiuso						
Armadio frigo verticale						
Banco refrigerato			X	X	X	X
Parametro	Symbol	Unit				
Classe di efficienza energetica	EEC	-	C	A	A	A
Indice di efficienza energetica	EEl	-	47,98	18,77	21,29	22,02
Consumo energetico per 24 ore	E24h	kWh	5,340	1,299	1.438	1.438
Consumo energetico annuale	AEC	kWh	1949	474	525	525
Volume netto dello scomparto 1	Vn1	litre	96	96	88	77,5
Volume netto dello scomparto 2	Vn2	litre	96	96	88	77,5
Volume netto dello scomparto 3	Vn3	litre	96	96	88	77,5
Volume netto dello scomparto 4	Vn4	litre	-	-	-	-
Volume netto totale	VnT	litre	288	288	264	232
Classe climatica	CC		5	5	5	5
Refrigerante			R290	R290	R290	R290
Carico		kg	0.055	0.065	0.065	0.065
GWP			3	3	3	3
CO2 equivalente		CO ₂	0,165	0,195	0,195	0,195
Uso intensivo; questo apparecchio è stato progettato per l'uso a una temperatura ambiente fino a 40°C.			X	X	X	X
Informazioni di contatto:	HOSHIZAKI EUROPE B.V.					
	Address: Burgemeester Stramanweg 101 1101 AA Amsterdam, The Netherlands Tel.: +31 (0)20 691 84 99 - http://hoshizaki.europe.com/					

HOSHIZAKI

PREMIER UNDERCOUNTER



Marchio			HOSHIZAKI			
Modello			PREMIER F 4 A DL DL DR DR	PREMIER K/M 4 A DL DL DR DR	PREMIER K/M 4 A 2D 2D 2D 2D	PREMIER K/M 4 A 3D 3D 3D 3D
Usato previsto			Storage	Storage	Storage	Storage
Temperatura di esercizio per la				X	X	X
Temperatura di esercizio per il			X			
Armadio frigo multiuso						
Armadio frigo verticale						
Banco refrigerato			X	X	X	X
Parametro	Symbol	Unit				
Classe di efficienza energetica	EEC	-	C	A	A	A
Indice di efficienza energetica	EEL	-	44,77	17,37	21,87	22,79
Consumo energetico per 24 ore	E24h	kWh	5,67	1,319	1,612	1,612
Consumo energetico annuale	AEC	kWh	2070	481	588	588
Volume netto dello scomparto 1	Vn1	litre	96	96	88	77,5
Volume netto dello scomparto 2	Vn2	litre	96	96	88	77,5
Volume netto dello scomparto 3	Vn3	litre	96	96	88	77,5
Volume netto dello scomparto 4	Vn4	litre	96	96	88	77,5
Volume netto totale	VnT	litre	384	384	352	310
Classe climatica	CC		4	5	4	4
Refrigerante			R290	R290	R290	R290
Carico		kg	0.055	0.065	0.065	0.065
GWP			3	3	3	3
CO2 equivalente		CO ₂	0,165	0,195	0,195	0,195
Usato intensivo; questo apparecchio è stato progettato per l'uso a una temperatura ambiente fino a 40°C.				X		
Informazioni di contatto:	HOSHIZAKI EUROPE B.V.					
	Address: Burgemeester Stramanweg 101 1101 AA Amsterdam, The Netherlands Tel.: +31 (0)20 691 84 99 - http://hoshizaki.europe.com/					

PREMIER UNDERCOUNTER

II. ISTRUZIONI PER L'USO

ENERGIA ELETTRICA

Prima di collegare il prodotto alla rete elettrica, verificare che l'alimentazione elettrica indicata sull'etichetta descrittiva del prodotto corrisponda all'alimentazione elettrica fornita dalla rete locale.

L'etichetta descrittiva del prodotto, su cui è riportata l'alimentazione elettrica appropriata, è situata all'interno dell'armadio nella parte superiore sinistra.

L'installazione del prodotto può essere eseguita solo da personale tecnico qualificato e addestrato secondo le specifiche riportate nel presente manuale.

La sicurezza elettrica dell'armadio frigo è garantita solo se l'apparecchio è collegato a terra conformemente alle vigenti leggi e norme locali.

Il collegamento a terra del prodotto è sempre obbligatorio.

Il produttore non potrà essere ritenuto responsabile dei danni derivanti da un'errata messa a terra.

Rispettare i requisiti elettrici previsti dalle norme locali in materia di energia elettrica. La spina elettrica del prodotto e la presa a muro devono essere provviste della corretta messa a terra. In caso di necessità rivolgersi a un elettricista qualificato.

CONTROLLI PRELIMINARI GENERALI

Verificare che l'armadio frigo poggi su una superficie piana e che sia in posizione verticale. A tale scopo, se necessario è possibile utilizzare i piedini regolabili dell'armadio. Tutti i piedini devono essere a contatto con il suolo. Questo è necessario per il corretto funzionamento della porta dell'armadio.

Non collocare l'armadio frigo vicino ad apparecchi che producono calore, quali forni, grill e friggitorici. Non esporre il prodotto alla luce solare diretta. È necessario isolare con un materiale isolante appropriato le pareti e i pavimenti che potrebbero irradiare calore. L'armadio frigo deve essere sistemato più lontano possibile da qualsiasi sorgente di calore.

Se l'armadio frigo viene spostato, lasciare trascorrere almeno tre ore prima di riaccenderlo. Rimuovere le protezioni in plastica e il nastro dalle superfici esterne.

Accertarsi che il prodotto sia posizionato in modo da consentire una sufficiente circolazione d'aria fresca al/dal circuito di raffreddamento e intorno alle superfici dell'armadio. Lasciare almeno 500 mm di spazio libero al di sopra dell'armadio.

Se due frigoriferi o congelatori vengono messi uno accanto all'altro, devono esserci almeno 50 mm di spazio tra essi.

Non bloccare i fori di ventilazione.

CONTROLLO PRELIMINARE DEI COLLEGAMENTI ELETTRICI

- Verificare che la tensione di rete e la frequenza della presa elettrica siano conformi ai dati riportati sull'etichetta descrittiva del prodotto.
- L'armadio frigo è collegato a una presa di alimentazione con un fusibile da 13-16 Amp con connessione seriale.
- Disattivare il fusibile di rete collegato al cavo di alimentazione.
- Verificare che la spina dell'apparecchio sia idonea per l'uso con la presa di rete disponibile e che la spina e la presa siano adatte una all'altra.

PREMIER UNDERCOUNTER

PRIMO UTILIZZO E CONTROLLI

Dopo avere eseguito i controlli descritti sopra, è possibile iniziare ad usare l'armadio frigo. L'interruttore ON/OFF consente di azionare l'apparecchio.

Quando si accende l'armadio frigo mediante l'interruttore ON, il compressore viene attivato. Il compressore rimane attivo fino a quando non viene raggiunta la temperatura preimpostata in fabbrica. Prima di riporre alimenti nell'armadio frigo, occorre regolare l'impostazione di temperatura in base agli alimenti da refrigerare.

Per impostare nuovi valori di temperatura, utilizzare il controller nel modo descritto in questo manuale.



IMPORTANTE

- Prima di introdurre alimenti nell'armadio frigo, lasciare raffreddare l'apparecchio alla temperatura impostata.
- Non superare mai la capacità di carico massima. La capacità massima dei ripiani corrisponde a un carico uniforme di 40 kg per ogni ripiano negli armadi frigo verticali e di 20 kg per i ripiani e i cassetti nei banchi refrigerati.
- Per informazioni sulla quantità di spazio necessaria per garantire un'adeguata ventilazione intorno al prodotto, vedere la sezione "Controlli preliminari generali" del presente manuale.
- Non conservare sostanze esplosive, quali bombolette spray con propellente infiammabile, all'interno di questo apparecchio.
- In caso di cassetto 1/3, non è possibile utilizzare il coperchio del contenitore con dispositivo di tenuta.

AVVERTENZA:

- Non ostruire in alcun momento le fessure di ventilazione dell'apparecchio.
- Non utilizzare dispositivi meccanici o altri mezzi diversi da quelli indicati dal produttore per accelerare il processo di sbrinamento.
- Evitare di danneggiare il circuito del refrigerante.
- Non utilizzare apparecchi elettrici all'interno dell'armadio frigo.
- Non danneggiare il cavo di alimentazione, il cablaggio o qualsiasi componente fondamentale.

CONDIZIONI DI CONSERVAZIONE E PRESTAZIONI

Le corrette condizioni di conservazione non solo sono essenziali per garantire l'igiene e la sicurezza alimentare, ma migliorano la qualità della manutenzione e riducono il consumo energetico. Per ottenere le prestazioni migliori, conservare gli alimenti solo sui ripiani, non collocarli mai sul fondo dell'armadio frigo. Gli alimenti devono essere riposti nell'armadio frigo o nel banco refrigerato in modo da consentire un'adeguata circolazione dell'aria intorno ad essi, lasciando dunque spazio libero tra gli alimenti e le pareti del prodotto. Se necessario è possibile regolare la distanza tra i ripiani.



III. PANNELLO DI CONTROLLO



➤ FUNZIONI DEL PANNELLO ANTERIORE

Per bloccare i tasti del pannello anteriore, tieni premuto AUX (3) e On / Stand By (1) per 2 secondi: quando i tasti sono bloccati, sullo schermo apparirà il testo “Loc”; se non è bloccato, apparirà il testo “UnL”.

- 1) Tenendo premuto **ON/STAND BY** per 4 secondi, il dispositivo si apre o si chiude. (On/Off)
- 2) **SBRINAMENTO MANUALE**; se il pulsante viene premuto per 4 secondi, inizia lo sbrinamento manuale. Se è attivo il raffreddamento eccessivo e la temperatura dell'evaporatore non è adatta, lo sbrinamento manuale non si avvia.
- 3) Freccia **GIÙ**: Scorrere verso il basso il menu o ridurre il valore; se tenuto premuto per 4 secondi si attiva il super raffreddamento. Quando la funzione di raffreddamento eccessivo è attiva, la temperatura impostata può essere ridotta; il tempo e la temperatura sono determinati con l'aiuto dei parametri. Quando la funzione di raffreddamento eccessivo è attivata, l'apparecchio non si sbrina mai.
- 5) Freccia **SU**: Scorrere verso l'alto il menu o aumentare il valore; se tenuto premuto per 4 secondi, si attiva la funzione di percentuale di umidità relativa bassa e alta. (Per alcuni modelli) sullo schermo compare “rhL” (è in funzione una bassa percentuale di funzione di umidità relativa) o “rhH” (è in funzione una percentuale di funzione di umidità relativa alta). Queste funzioni appaiono sullo schermo per 10 secondi. Se il controllo dell'umidità non è disponibile, sullo schermo appare “----” per 1 secondo.
- 6) Tasto **SET**: tasto di inserimento e modifica dei valori regolabili.

➤ FUNZIONAMENTO

I casi di funzionamento sono disponibili qui sotto:

Stato “On”: (il dispositivo è alimentato e funziona).

Stato “Stand-By”: (il dispositivo è spento ma è ancora alimentato).

Stato “Off”: per spegnere il dispositivo, rimuovere la spina dalla presa o spegnere il fusibile principale; il dispositivo è spento.

PREMIER UNDERCOUNTER

IV. ISTRUZIONI PER LA MANUTENZIONE

Pulire regolarmente il refrigeratore. Gli intervalli dipendono dall'uso e dal livello di sporcizia (pulirlo almeno annualmente).



Prima di eseguire qualsiasi operazione di pulizia o manutenzione, scollegare la macchina dall'alimentazione



Non toccare né bagnare i componenti dello scomparto motore. Ciò potrebbe provocare anomalie o guasti.



Per evitare danni, non pulire le parti in plastica con acqua ad una temperatura superiore a 40 °C o in lavastoviglie.

Interno ed esterno dell'armadio frigo e dei ripiani



Effettuare la pulizia e disinfezione della parte interna ed esterna almeno una volta alla settimana.



Pulire l'interno e l'esterno dell'armadio frigo con un panno morbido dopo averlo immerso in acqua fredda o tiepida, contenente la corretta quantità di detergente neutro, e averlo strizzato completamente. Non utilizzare getti d'acqua per pulire lo scomparto motore.



Sostanze chimiche diverse da un detergente neutro possono danneggiare le superfici interne ed esterne.



Eventuali residui di detergente sono dannosi per le superfici in metallo o in plastica. Per eliminarli, utilizzare un panno morbido inumidito con acqua tiepida.



Non usare i seguenti articoli, che potrebbero danneggiare le superfici verniciate o in plastica:

- lucidanti in polvere, alcool, diluenti, benzene, detergenti acidi o alcalini, acqua bollente, petrolio, sapone in polvere, pagliette o spazzole in metallo ecc. Evitare in particolare qualsiasi sgrassatore per ventole o forni a microonde.

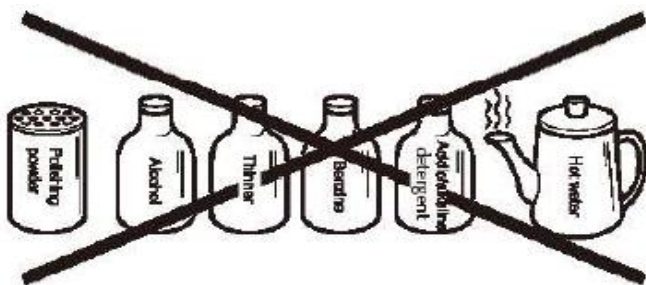

Nota: anche altre soluzioni non contenute nell'elenco riportato in precedenza possono danneggiare le superfici in plastica o verniciate. Cessare immediatamente il loro utilizzo nel caso in cui sorgano problemi!

PREMIER UNDERCOUNTER



La guarnizione del portello e la relativa superficie di contatto si sporcano con facilità. Pulire con cura ciascuna superficie di questi componenti. Le tracce di alimenti sui componenti ne accelerano il deterioramento.



Utilizzare un panno per eliminare l'acqua che ristagna nel vano frigorifero.

Condensatore



Usare un aspirapolvere o una spazzola morbida per rimuovere la polvere e le macchie dal condensatore.



Avvertenza: se si pulisce il condensatore con una spazzola dura, come quella della lavastoviglie, il rivestimento del condensatore potrebbe staccarsi.

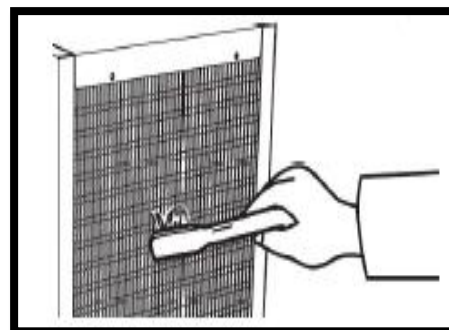

Filtro dell'aria



Non sciacquare il filtro dell'aria con acqua calda a temperatura superiore a 40 °C, per impedirne la deformazione



I filtri dell'aria a maglia di plastica servono a filtrare l'aria dalle impurità e dalla polvere, proteggendo il condensatore da eventuali intasamenti. In caso di ostruzione dei filtri, le prestazioni del frigorifero/congelatore si riducono.



Controllare i filtri almeno due volte al mese. Quando il filtro è intasato o quando il regolatore di temperatura mostra "CH", usare acqua calda e un detergente neutro per lavare i filtri. Non far funzionare la macchina con il filtro dell'aria smontato, per evitare che il condensatore si intasi e si guasti.

- 1) Aprire il pannello anteriore e smontare il filtro dell'aria. Per evitare lesioni, non toccare direttamente le alette del condensatore.
- 2) Lavare con cura il filtro dell'aria con acqua fredda o tiepida, contenente la corretta quantità di detergente neutro. Risciacquare e asciugare con cura il filtro dell'aria.
- 3) Per rimontare il filtro dell'aria, inserire le due linguette nello scambiatore di calore o nelle alette del condensatore e fissare saldamente il filtro dell'aria sul condensatore.

PREMIER UNDERCOUNTER

V. INFORMAZIONI TECNICHE

DIMENSIONI DEI DISPOSITIVI

PREMIER K-M-F 2 A DL DR L

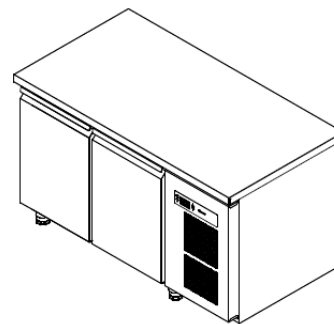
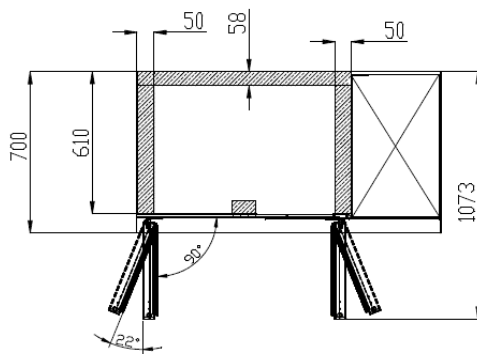
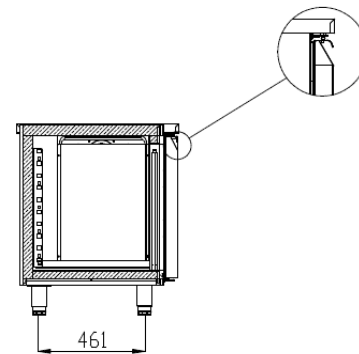
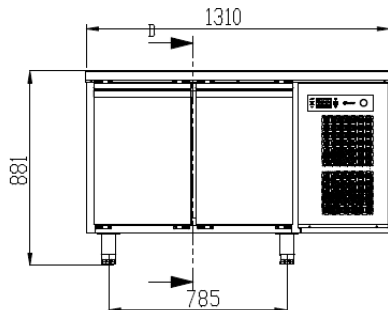

PREMIER K-M-F 2 A DL DR C

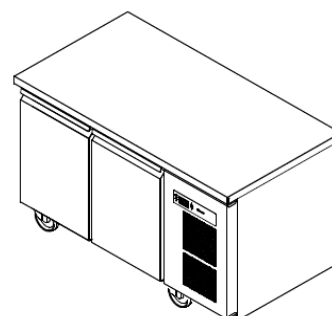
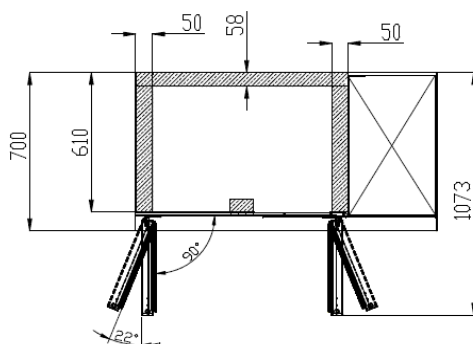
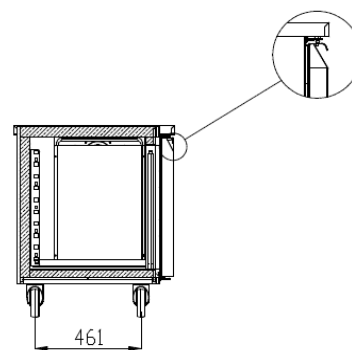
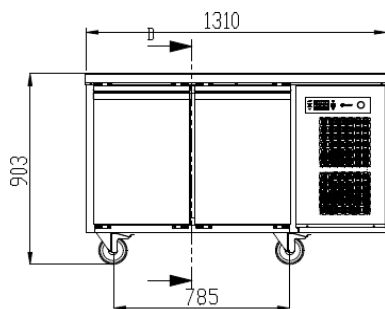

HOSHIZAKI

PREMIER UNDERCOUNTER



PREMIER K-M 2 A 2D 2D L

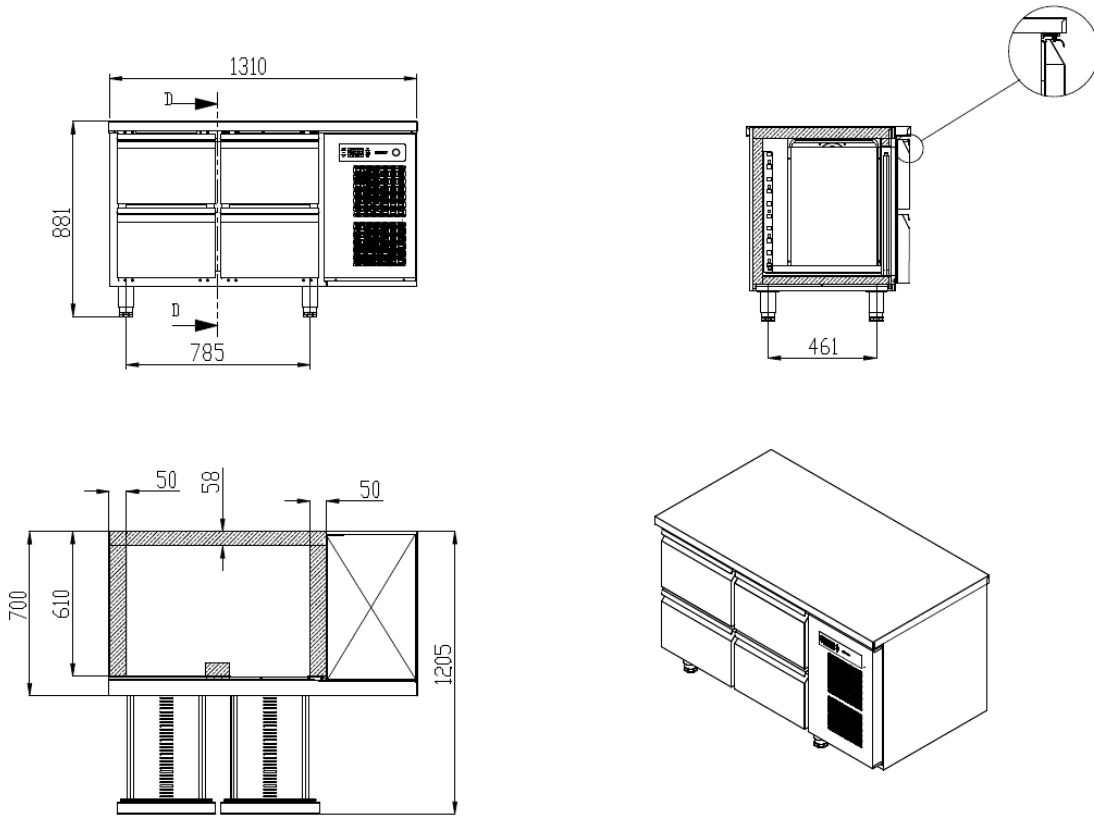

PREMIER K-M 2 A 2D 2D C

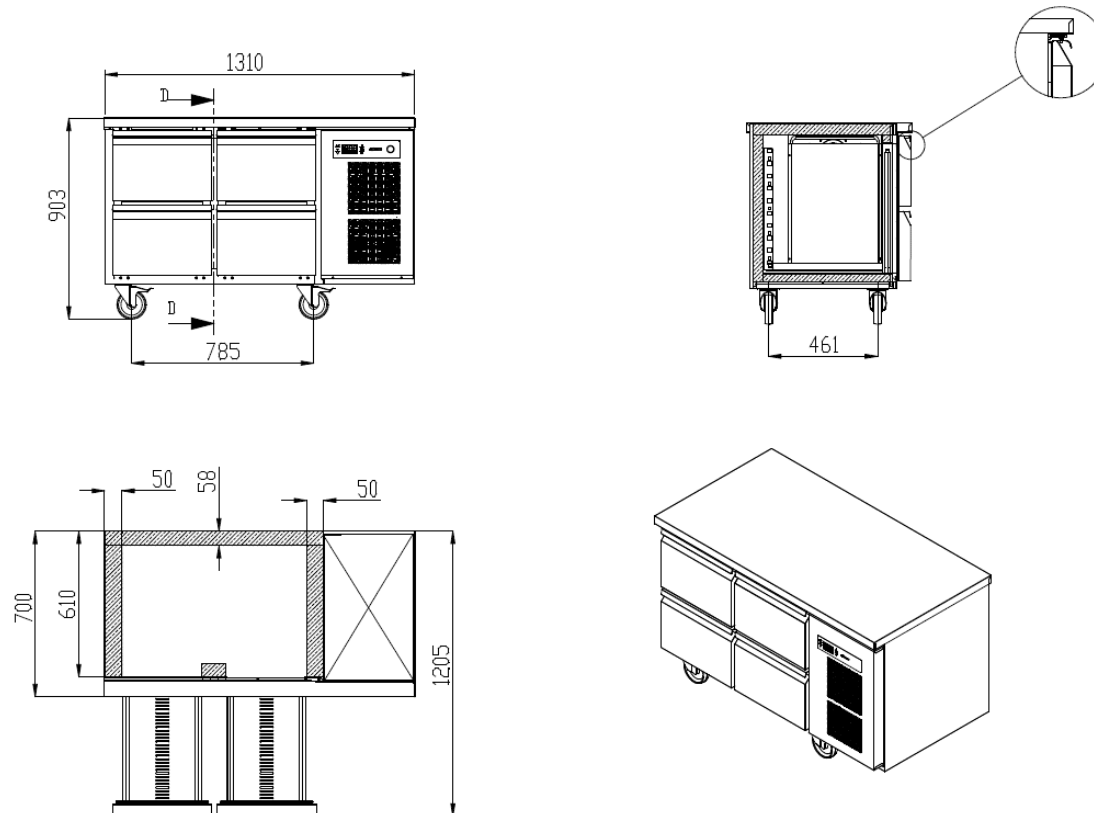

HOSHIZAKI

PREMIER UNDERCOUNTER



PREMIER K-M 2 A 3D 3D L

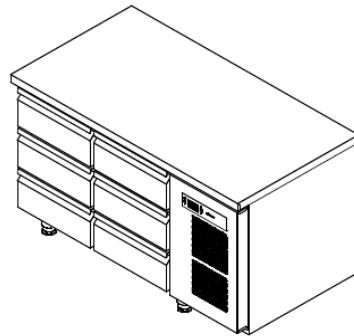
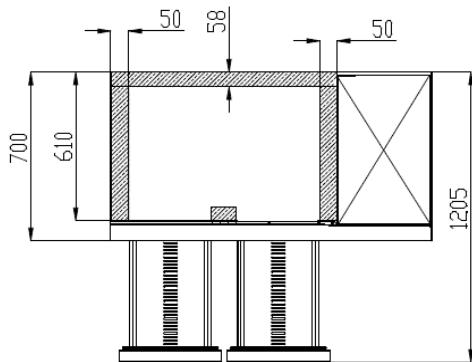
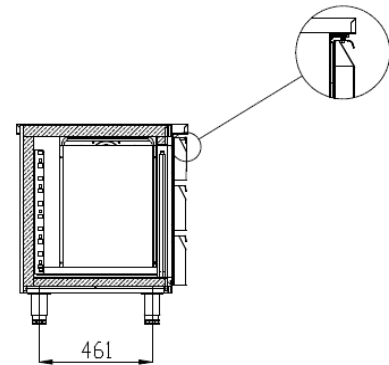
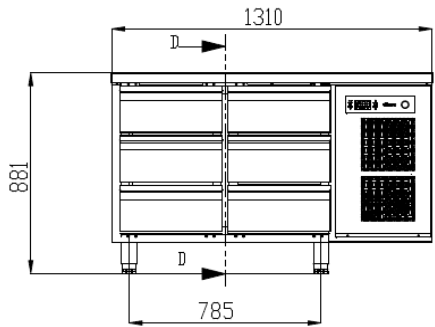

PREMIER K-M 2 A 3D 3D C

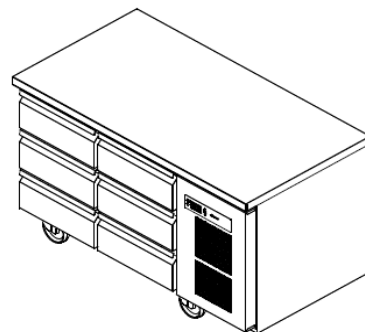
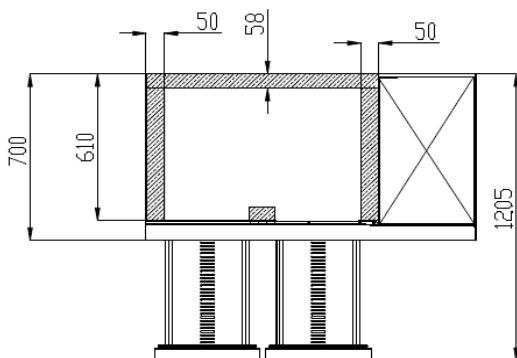
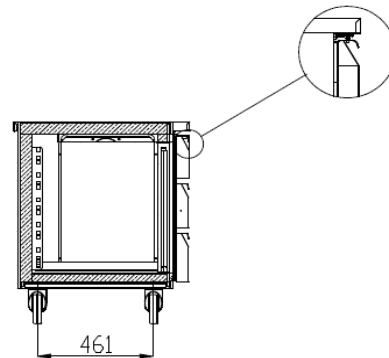
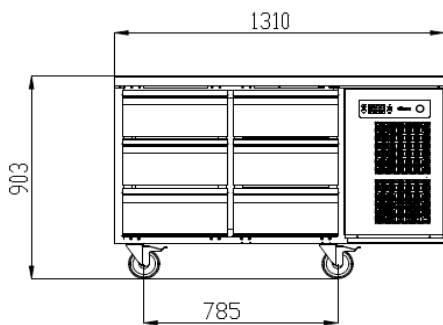

HOSHIZAKI

PREMIER UNDERCOUNTER



PREMIER K-M-F 3 A DL DR DR L

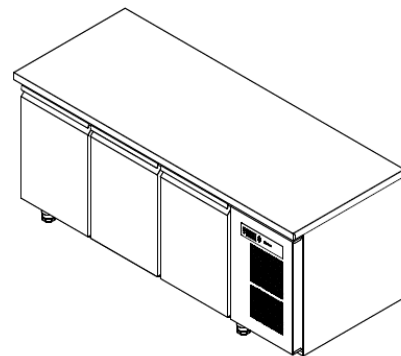
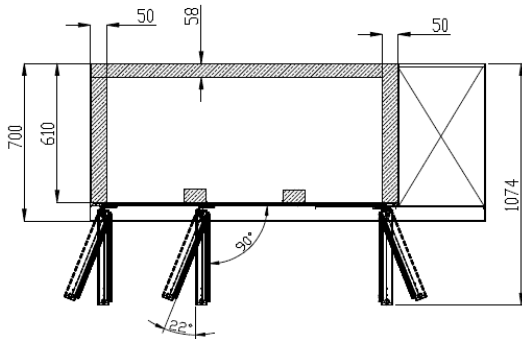
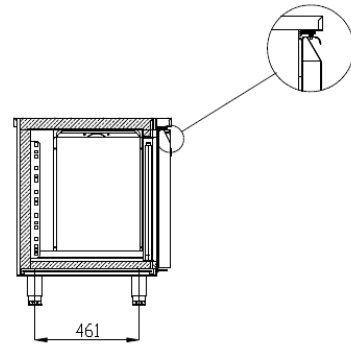
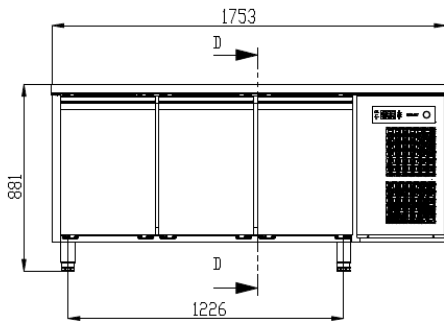

PREMIER K-M-F 3 A DL DR DR C

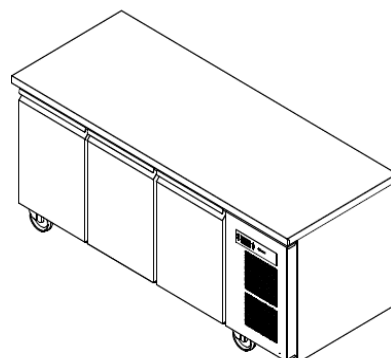
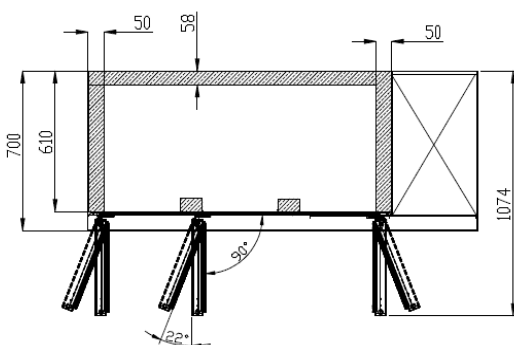
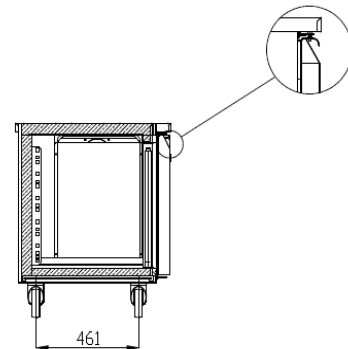
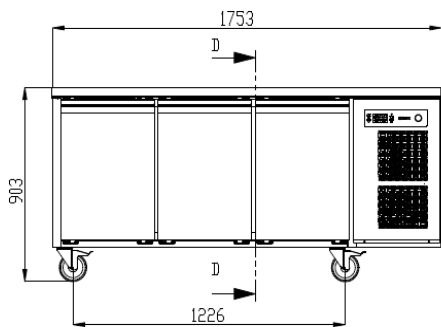

HOSHIZAKI

PREMIER UNDERCOUNTER



PREMIER K-M 3 A 2D 2D 2D L

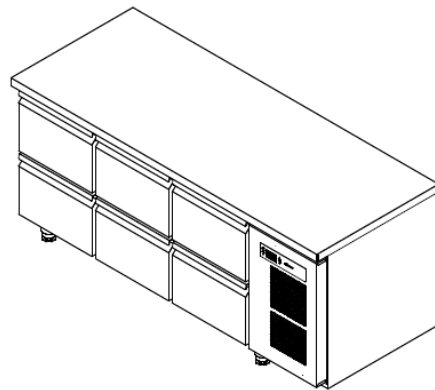
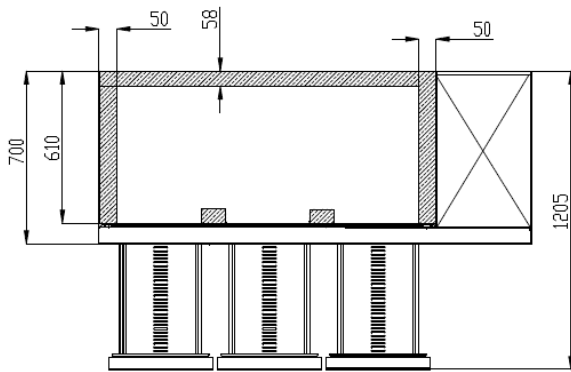
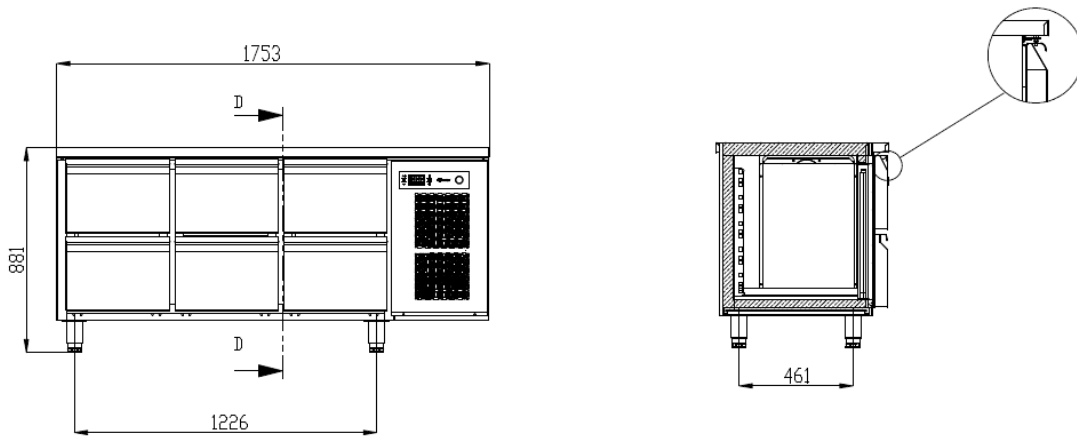

PREMIER K-M 3 A 2D 2D 2D C

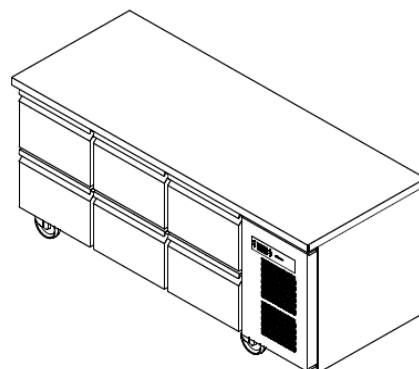
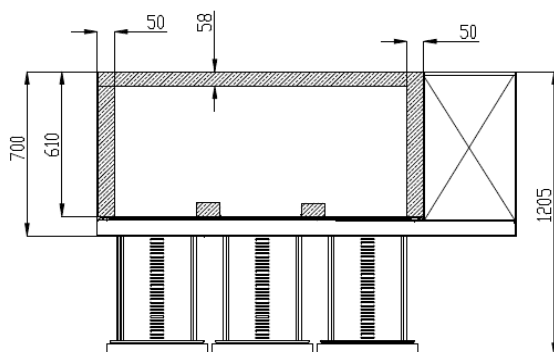
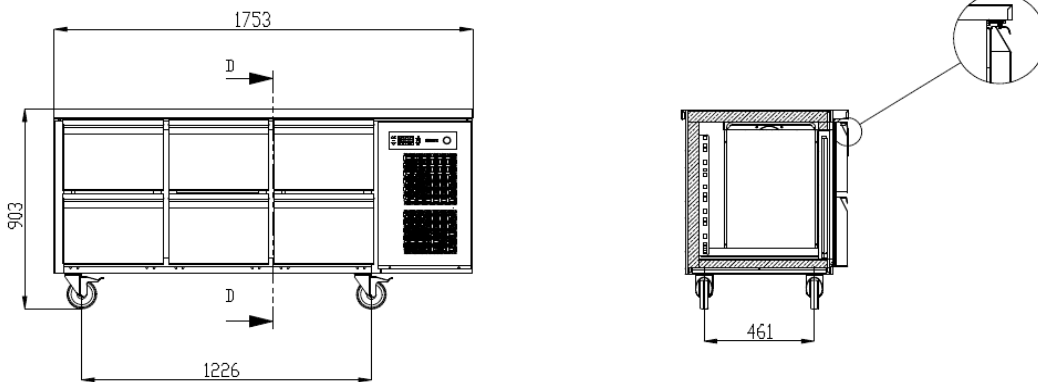

HOSHIZAKI

PREMIER UNDERCOUNTER



PREMIER K-M 3 A 3D 3D 3D 3 L

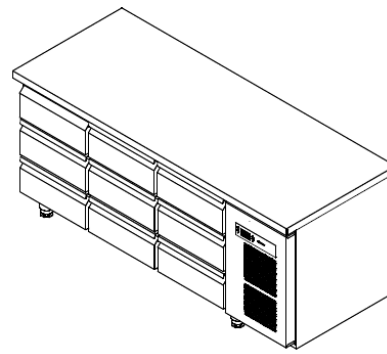
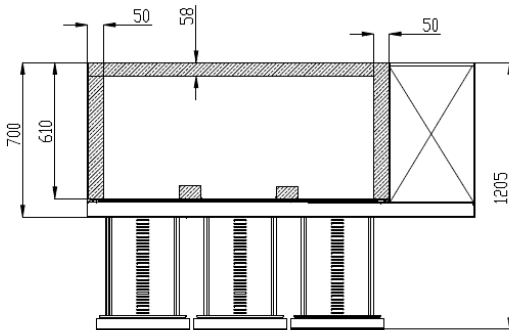
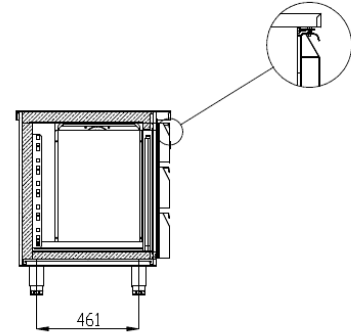
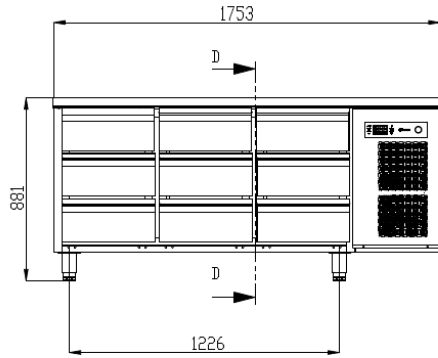

PREMIER K-M 3 A 3D 3D 3D 3 C

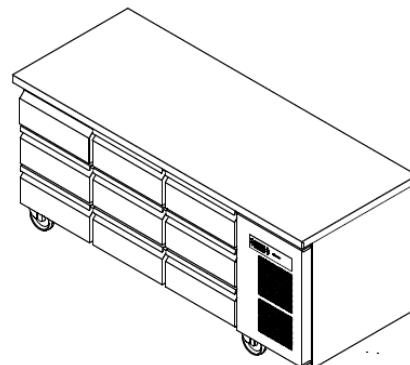
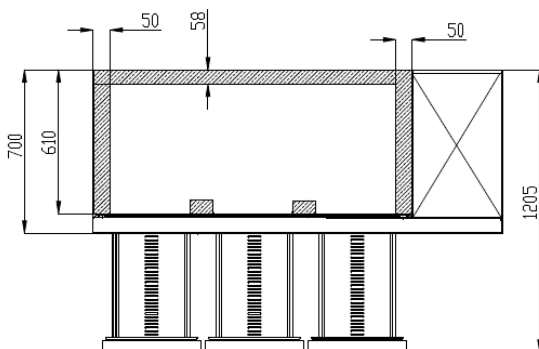
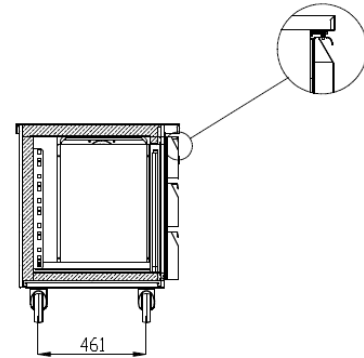
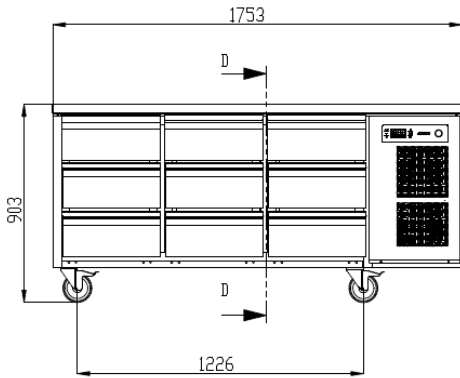

HOSHIZAKI

PREMIER UNDERCOUNTER



PREMIER K-M-F 4 A DL DL DR DR L

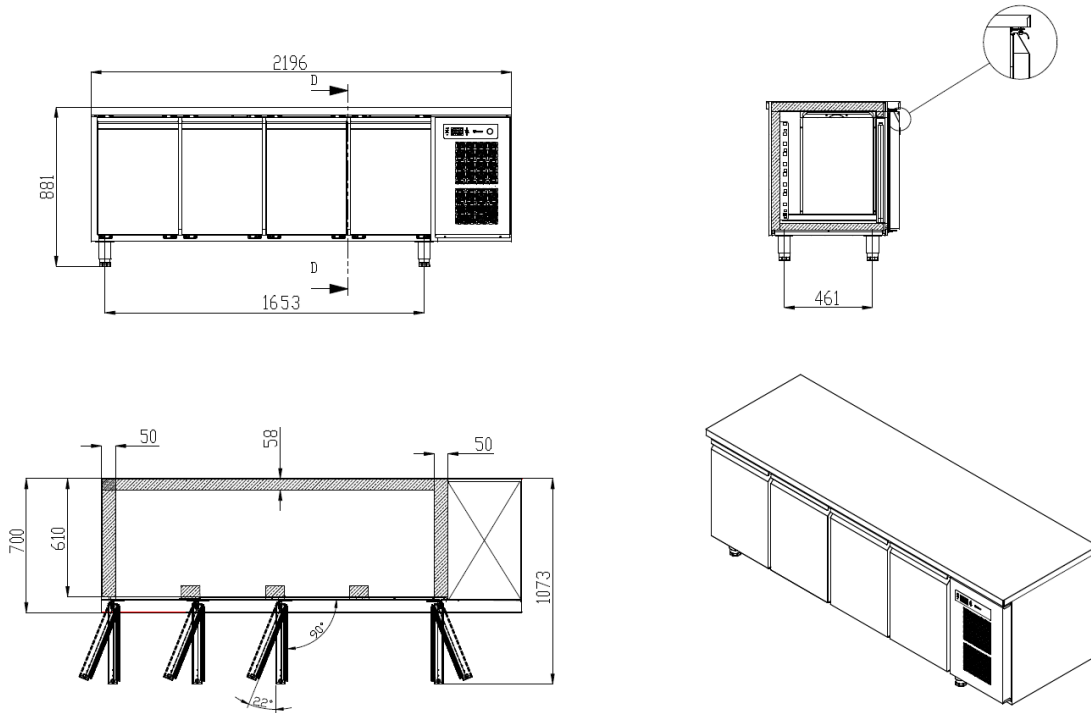

PREMIER K-M-F 4 A DL DL DR DR C

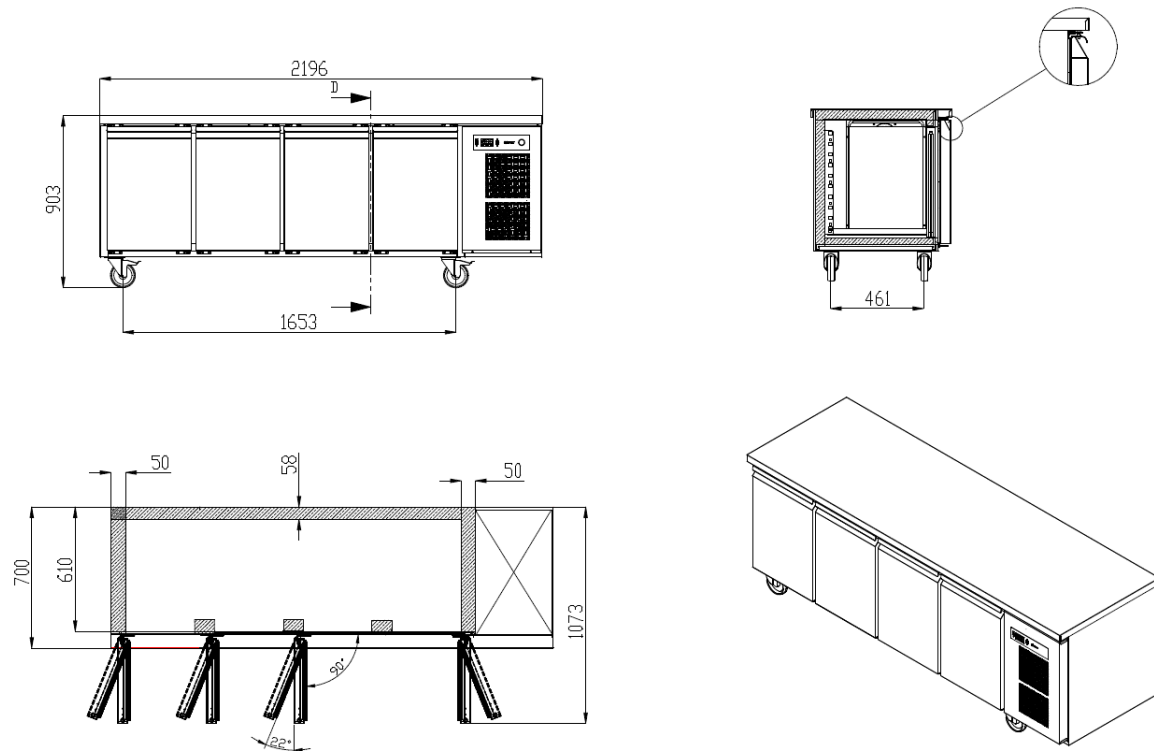

HOSHIZAKI

PREMIER UNDERCOUNTER



PREMIER K-M 4 A 2D 2D 2D 2D L

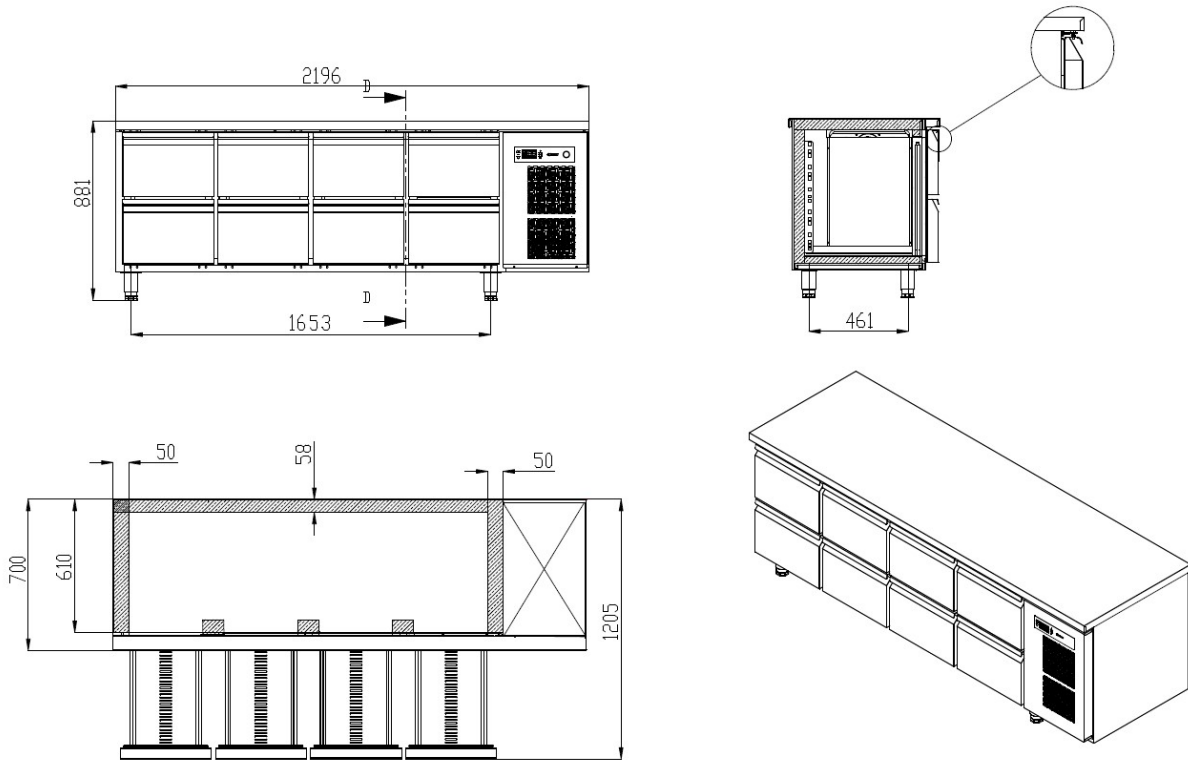

PREMIER K-M 4 A 2D 2D 2D 2D C

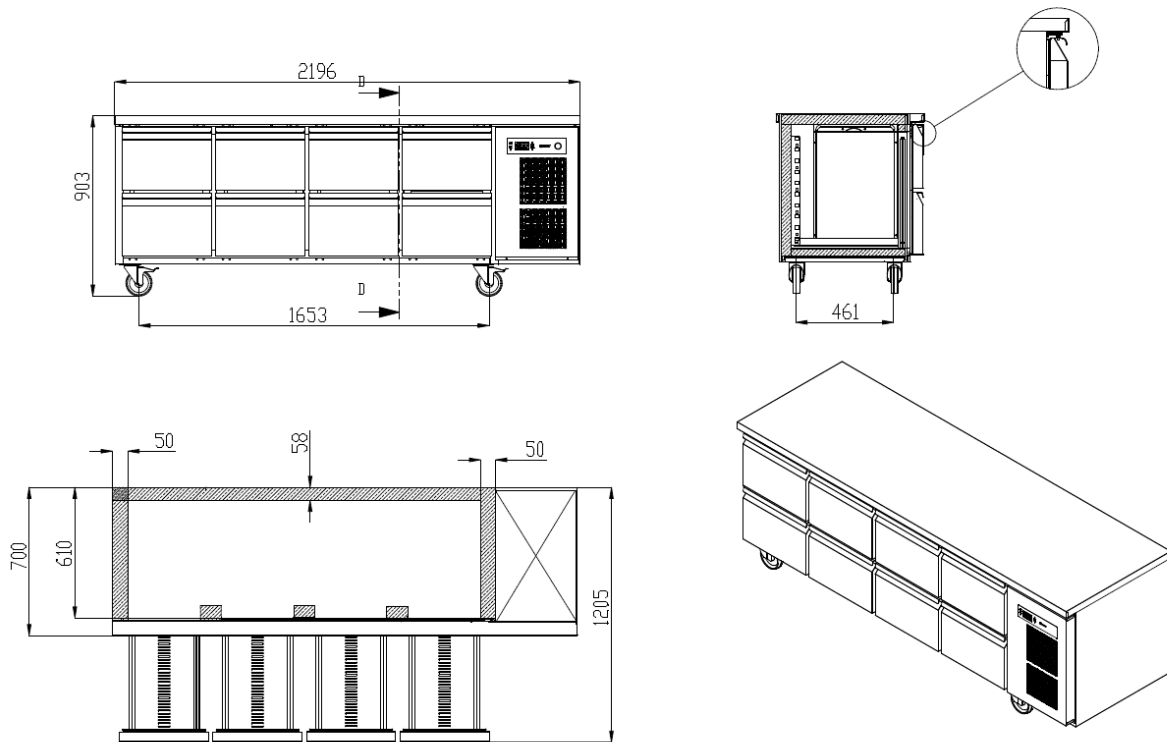

HOSHIZAKI

PREMIER UNDERCOUNTER



PREMIER K-M 4 A 3D 3D 3D 3D L

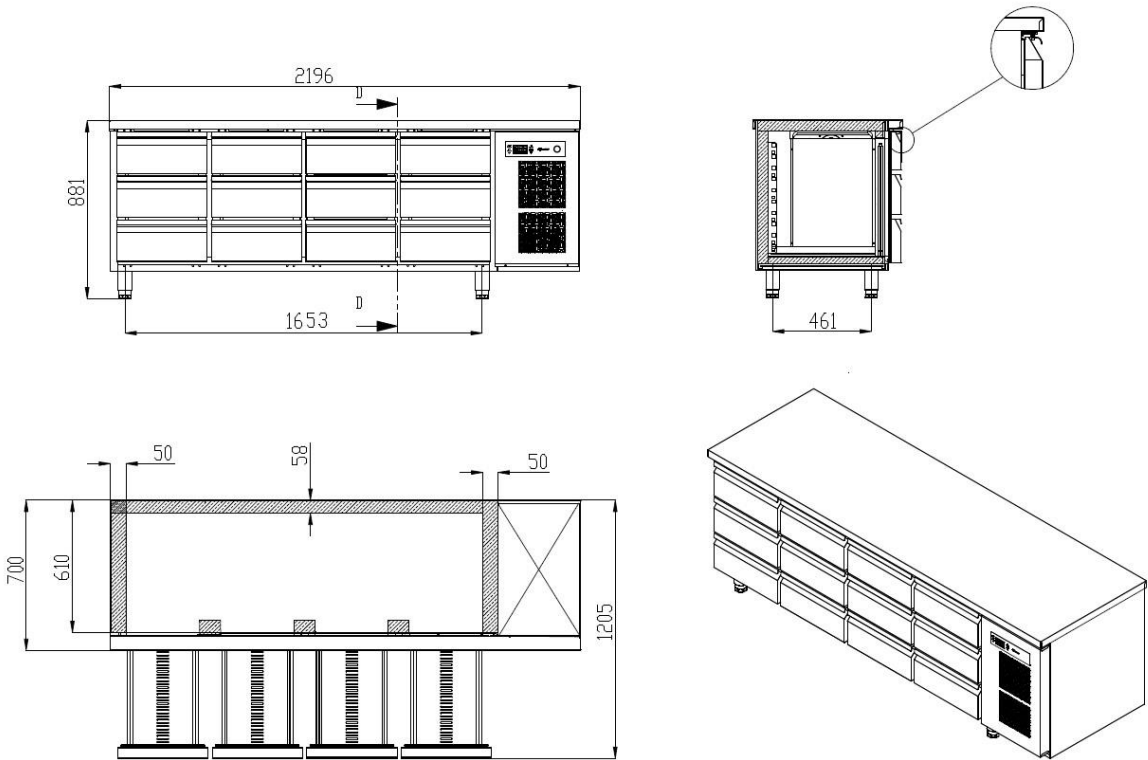

PREMIER K-M 4 A 3D 3D 3D 3D C

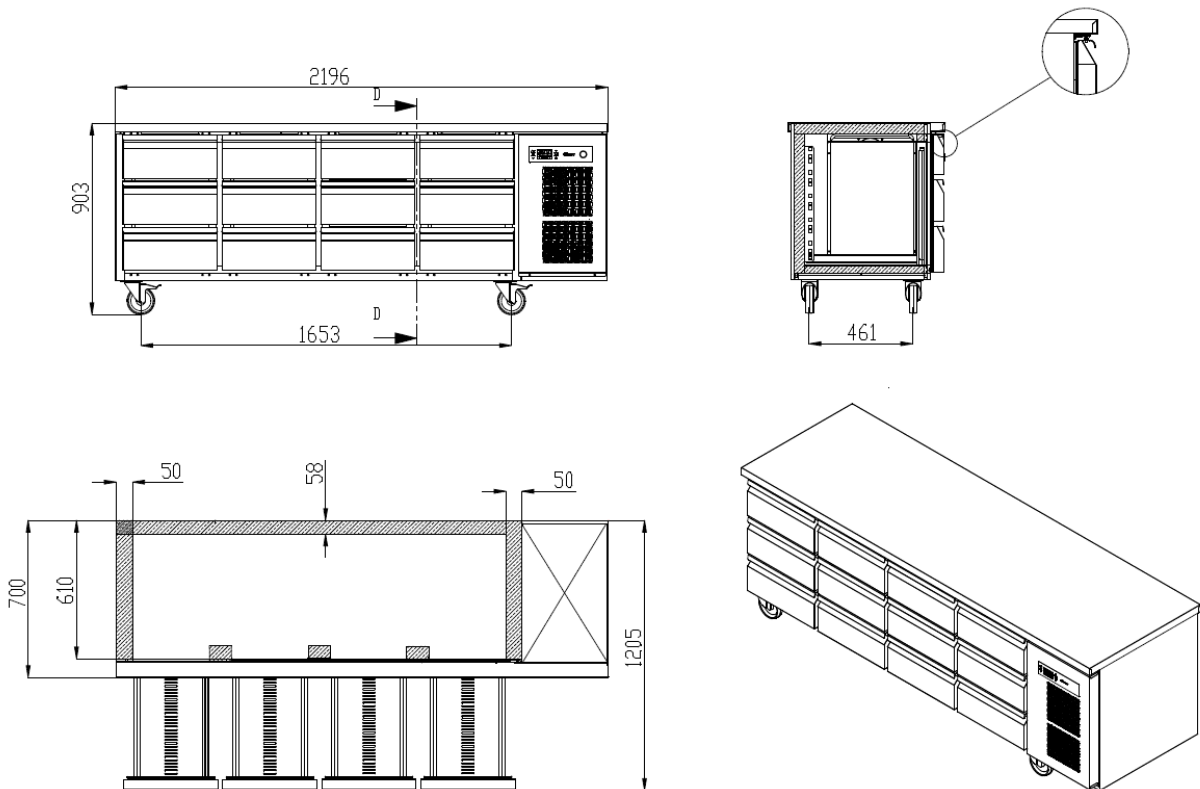

PREMIER UNDERCOUNTER

VI. SCHEMA DI RAFFREDDAMENTO - SCHEMA ELETTRICO

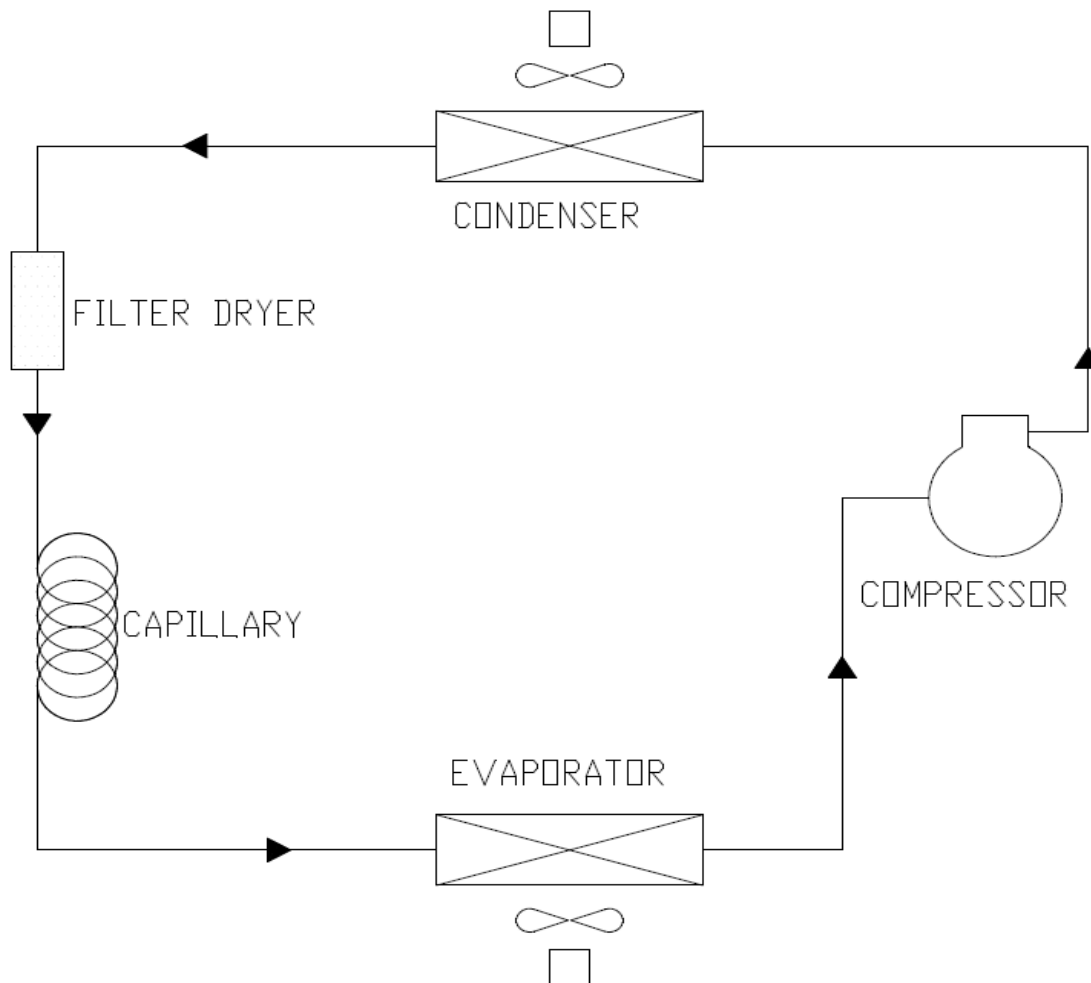



HOSHIZAKI

PREMIER UNDERCOUNTER

SCHEMA ELETTRICO

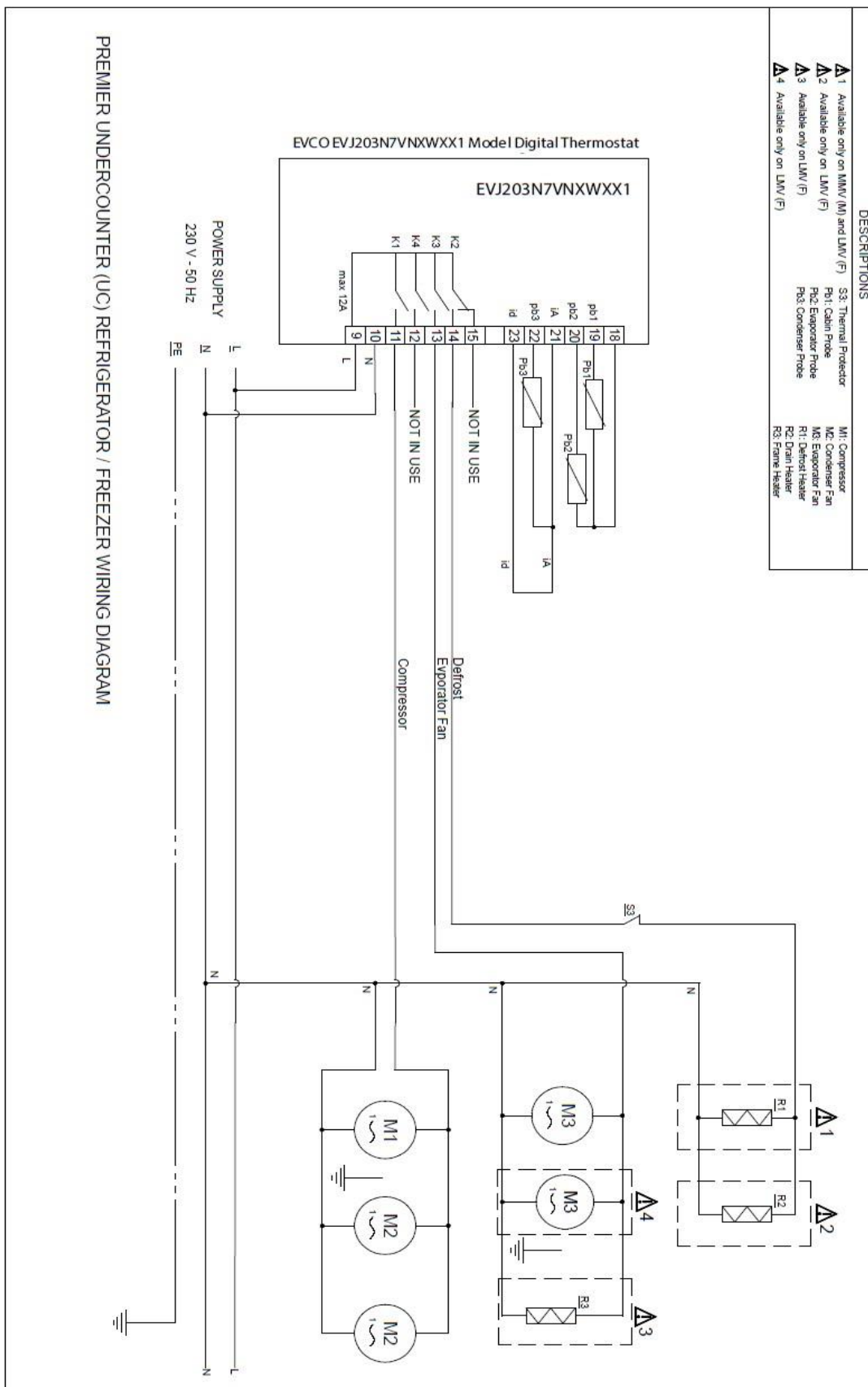

PREMIER UNDERCOUNTER

VII. RISOLUZIONE DEI PROBLEMI

Nella tabella seguente sono elencati diversi problemi che potrebbero verificarsi. Se viene visualizzato un codice di allarme significa che si è verificato un malfunzionamento. Correggere l'errore prima di reimpostare l'armadio frigo. Le cause possibili e le relative soluzioni sono descritte di seguito.

Se il codice di errore persiste anche dopo avere eseguito i controlli sotto indicati, contattare un tecnico autorizzato. È necessario fornire le caratteristiche del messaggio di errore. I dati riguardanti il prodotto, incluso il numero di serie, sono reperibili sulla targhetta identificativa del prodotto stesso.

PROBLEMA	CAUSA POSSIBILE	SOLUZIONE	
L'armadio frigo non funziona	L'armadio frigo non viene alimentato	Verificare che la spina e il cavo di alimentazione siano privi di guasti	
Ogni tanto il compressore smette di funzionare	La temperatura ambiente è troppo alta	È necessario migliorare la ventilazione	
	Il condensatore o il filtro del condensatore è bloccato	Controllare e pulire regolarmente il filtro del condensatore	
	Le guarnizioni delle porte non aderiscono perfettamente	Contattare un tecnico autorizzato per la sostituzione delle guarnizioni	
	L'evaporatore è coperto di ghiaccio		Non introdurre alimenti caldi nell'armadio frigo
			Non introdurre alimenti con un alto contenuto di acqua nell'armadio frigo a meno che non siano riposti in contenitori con chiusura ermetica Eseguire un ciclo di sbrinamento manuale
	Le ventole dell'evaporatore sono guaste	Contattare un tecnico autorizzato per la sostituzione delle ventole	
L'acqua trabocca dalla vaschetta di raccolta dell'acqua del condensatore	Frequente introduzione di alimenti caldi nell'armadio frigo	Non introdurre alimenti caldi nell'armadio frigo	
		Introdurre alimenti con un alto contenuto di acqua nell'armadio frigo solo se sono riposti in contenitori con chiusura ermetica	
	Frequente apertura della porta o dei cassetti	Verificare che le specifiche dell'armadio frigo siano compatibili con il tipo di corrente elettrica	
La temperatura dell'armadio frigo è troppo alta	Il condensatore è ostruito da sporcizia e polvere	Controllare e pulire regolarmente il filtro del condensatore	
	La circolazione dell'aria all'interno dell'armadio frigo è bloccata	Rimuovere gli alimenti che bloccano la circolazione dell'aria	
	L'aria ambiente penetra nell'armadio frigo		Verificare che la porta sia ben chiusa
			Controllare che le guarnizioni della porta e dei cassetti non siano danneggiate Contattare un tecnico autorizzato
	L'evaporatore è coperto di ghiaccio	Eseguire un ciclo di sbrinamento manuale	

PREMIER UNDERCOUNTER

VIII. RIMOZIONE E SOSTITUZIONE

SMALTIMENTO DELL'ARMADIO FRIGO

- a. Il tipo di gas refrigerante presente nell'armadio frigo è indicato sulla targhetta identificativa.
- b. L'armadio frigo è realizzato in materiali riciclabili conformemente alle normative europee. Di conseguenza, al termine del suo ciclo di vita, l'armadio frigo deve essere conferito al centro di raccolta appropriato per lo smaltimento.
- c. Non smaltire l'armadio frigo come metallo o insieme ai rifiuti domestici.
- d. Non comprimere il circuito di refrigerazione dell'impianto di raffreddamento.



IMPORTANTE

Per il corretto smaltimento dell'armadio frigo, rispettare le leggi e le norme locali.

HOSHIZAKI

PREMIER UNDERCOUNTER



Tutti i diritti riservati. Hoshizaki si riserva il diritto di apportare modifiche alle funzioni e alle informazioni contenute nel presente manuale.

Informazioni di contatto

Sede centrale

Hoshizaki Europe B.V – All other countries in Europe and Africa

TEL: +31 (0)20 6918499

sales@hoshizaki.nl -- <http://hoshizaki-europe.com/>

Filiali

Hoshizaki UK - UK, Ireland

TEL: +44 (0)845 456 05 85

uksales@hoshizaki.co.uk

Hoshizaki Deutschland - Germany, Switzerland, Austria

TEL: +49 (0)5121 697370

vertrieb@hoshizaki.de

Hoshizaki Benelux - Netherlands, Belgium, Luxembourg

TEL: +31 (0)85 0188370

info@hoshizaki.nl

Hoshizaki France - France

TEL: +33 (0)1 48 63 93 80

info@hoshizaki.fr

Hoshizaki Iberia - Spain, Portugal

TEL: +34 (0)93 478 09 52

info@hoshizaki.es

Hoshizaki Denmark - Denmark

TEL: +45 89 88 53 50

salg@hoshizaki.dk

Hoshizaki Norway - Norge

TEL: +47 22 88 17 50

salg@hoshizaki.no

Hoshizaki Sweden - Sverige

TEL: +46 108 84 87 47

OrderSE@hoshizaki.dk

Hoshizaki Italia – Italia

TEL: +39 348 3022156

commerciale@hoshizaki.it

HOSHIZAKI

PREMIER UNDERCOUNTER



HOSHIZAKI

PREMIER UNDERCOUNTER



KYLSKÅP OCH FRYSAR HANDBOK FÖR ANVÄNDNING, UNDERHÅLL OCH INSTALLATION



I. ALLMÄN INFORMATION	184
II. ANVÄNDNINGSSINSTRUKTIONER	189
III. KONTROLLPANEL	191
IV. UNDERHÅLLSANVISNINGAR	192
V. TEKNISK INFORMATION	194
VI. KYLSHEMA – ELEKTRISKT KOPPLINGSSHEMA	203
VII. SERVICEDIAGNOS	205
VIII. DEMONTERING OCH BYTE	206

Kontaktuppgifter:

HOSHIZAKI EUROPE B.V.

Adress: Burgemeester Stramanweg 101 1101 AA Amsterdam, Nederländerna

Tel: +31 (0)20 691 8499 <http://hoshizaki-europe.com/>



PREMIER UNDERCOUNTER

I. ALLMÄN INFORMATION

PRODUKTDEKAL

1 – Produktnummer
2 – Produktbeskrivning
3 – Modell
4 – Köldmedel (GWP)
5 – CO ₂ -ekvivalent
6 – IP-skydd
7 – Klimatklass
8 – Tillverkningsdatum
9 – Total effekt/ström/lampans effekt
10 – Spänning – frekvens
11 – Värmeelement
12 – Systemtryck
13 – Jäsmedel
14 – Serienummer

PRODUCT NUMBER	1
----------------	---



PRODUCT DESCRIPTION	2
MODEL	3
REFRIGERANT	4
CO ₂ EQUIVALENT	5
IP PROTECTION	6
CLIMATE CLASS	7
PRODUCTION DATE	8
TOTAL POWER / CURRENT / LAMP POWER	9
VOLTAGE - FREQUENCY	10
HEATING ELEMENT	11
SYSTEM PRESSURE	12
BLOWING AGENT	13

S/N: 14



HOSHIZAKI EUROPE B.V. Burgemeester Stramanweg 101 1101 AA
Amsterdam, The Netherlands



SYFTET MED ANVÄNDNINGEN

- Produkten är endast lämplig för användning inomhus och endast för förvaring av mat och dryck. Förvaringsenheter som är utformade för att lagra produkter som har kyl-/frystemperatur.
- Tillverkaren ansvarar inte för eventuella skador som uppstår till följd av användning i strid med de riktlinjer som anges i den här boken.
- När mat förvaras i skåpet får maten aldrig komma i kontakt med höljet.
- Alla livsmedel måste täckas över ordentligt. För att undvika kontaminering och korrosion av inre komponenter ska alla produkter förpackas eller förvaras i förseglade behållare.
- Förvara inte varma matvaror eller vätskor i skåpet.
- Drycker som förvaras i lådor och glasflaskor får inte förvaras vid temperaturer under 0 °C (frysunkten). Burkar och glasflaskor kan explodera på grund av expansion. Behållare med lock får inte fyllas helt: en liten mängd utrymme bör lämnas för expansion.
- Skåpet är utrustat med en funktion för automatisk avfrostning. Det går också att avfrosta det manuellt. Manuell avfrostning innebär inte att skåpet stängs av under en längre period utan kan utföras via styrenheten. Under inga omständigheter får du använda fysisk kraft eller handverktyg för att avlägsna is från skåpet, skador som uppstår till följd av sådana åtgärder är svåra att reparera.
- Använd inte mekaniska eller alternativa avfrostningsmetoder.
- Maskinen får bara användas av personer (inklusive barn) med nedsatta fysiska, sensoriska eller kognitiva förmågor, eller brist på erfarenhet och kunskap, om de övervakas eller instrueras.
- Barn som övervakas får inte leka med apparaten.
- Rengöring och användarunderhåll får inte utföras av barn utan övervakning.

PREMIER UNDERCOUNTER

- Den här apparaten kan användas av barn från 8 års ålder, personer med nedsatta fysiska, sensoriska eller kognitiva förmågor och personer som saknar erfarenhet och kunskap om maskinen om de övervakas eller instrueras angående säker användning av apparaten samt är införstådda med riskerna.
- Alla elektriska eller mekaniska ändringar i det här skåpet upphäver garantin. Ändringar som utförs av ej auktoriserade servicetekniker och andra ändringar än de som beskrivs i den här handboken upphäver också garantin. Tillverkaren ansvarar inte för skador som uppstår till följd av sådana ändringar.

KLIMATKLASS

Skåpet är utformat att användas inom specifika omgivningstemperaturer och luftfuktighetsnivåer. De anges i klimatklassificeringssystemet. Dessa nivåer får aldrig överskridas. Klimatklassen för den här produkten anges på produktdekalen. Kylskåpet är inte lämpligt för användning i temperaturer under 16 °C omgivningstemperatur.

Klimatklass	Omgivningstemperatur och luftfuktighet
4	+30 °C med % 55 RH
5	+40 °C med % 40 RH

MOTTAGANDE OCH KONTROLLER

Skåp förpackas i skyddande förpackningsmaterial för transport. Kontrollera vid leveransen att skåpet inte har några transportskadorna och att skåpmodellen är den som du beställde.



VIKTIGT

Åtgärderna som anges nedan måste följa alla lokala lagar och säkerhetsföreskrifter. Följ alla gällande säkerhetsföreskrifter när produkten används.

TRANSPORT

När produkten lyfts med maskiner ska lyftkapaciteten hos maskinerna kontrolleras innan arbetet utförs.



VIKTIGT

När en gaffeltruck används för att flytta produkten ska du se till att gafflarna förs in i lämpliga öppningar på pallen.

Se till att produkten står stadigt under flytten. Om produktens tyngdpunkt inte är centralt placerad kan den välta. När produkten sänks ned med en gaffeltruck ska du se till att det sker långsamt och försiktigt.

Om ett stående skåp måste transporteras i horisontalt läge ska du se till att skåpet har stått upprätt i minst 2 timmar innan du använder det. Vi rekommenderar inte att du transporterar stående skåp horisontalt och skador som uppstår till följd av sådana åtgärder täcks inte av garantin.

PREMIER UNDERCOUNTER



OBSERVERA

Rekommendationer på utsidan av transportförpackningen är avsedda för användaren. Följande rekommendationer bör följas:

- Bär produkten försiktigt.
- Håll produkten torr. Använd inte skåpets ovansida för förvaring!

ÖPPNA FÖRPACKNINGEN

- Ta bort kartongen och annat eventuellt förpackningsmaterial.
- Lyft skåpet för att lossa det och ta bort det från lastpallen.
- Placera skåpet stående på basen på önskad plats.
- Kontrollera om det finns synliga skador.
- Förpackningsmaterialet kan återvinnas i enlighet med lokala återvinningsbestämmelser.
- Kontrollera att produktkoden och serienumret stämmer överens med de på leveransdokumenten.

Varumärke			HOSHIZAKI			
Modellnamn			PREMIER F 2 A DL DR	PREMIER K/M 2 A DL DR	PREMIER K/M 2 A 2D 2D	PREMIER K/M 2 A 3D 3D
Avsedd användning			Storage	Storage	Storage	Storage
Drifttemperatur vid kylning				X	X	X
Drifttemperatur vid frysning			X			
Skåp för flera användningsområden						
Vertikalt skåp						
Bänkskåp			X	X	X	X
Parameter	Symbol	Unit				
Energieffektivitetsklass	EEC	-	C	A+	A	A
Energieffektivitetsindex	EEl	-	40,26	13,9	17,42	17,85
24 timmars energiförbrukning	E24h	kWh	3,862	0,869	1,069	1,069
Årlig energiförbrukning	AEC	kWh	1410	317	390	390
Nettovolym för fack 1	Vn1	litre	96	96	88	77,5
Nettovolym för fack 2	Vn2	litre	96	96	88	77,5
Nettovolym för fack 3	Vn3	litre	-	-	-	-
Nettovolym för fack 4	Vn4	litre	-	-	-	-
Total nettovolym	VnT	litre	192	192	176	155
Klimatklass	CC		5	5	5	5
Köldmedium			R290	R600a	R600a	R600a
Laddning		kg	0.055	0.07	0.07	0.07
GWP			3	3	3	3
CO2-ekvivalent		CO ₂	0,165	0,21	0,24	0,21
Tålig, den här apparaten är avsedd för användning i omgivningstemperaturer upp till 40 °C			X	X	X	X
Kontaktuppgifter:			HOSHIZAKI EUROPE B.V.			
			Address: Burgemeester Stramanweg 101 1101 AA Amsterdam, The Netherlands Tel.: +31 (0)20 691 84 99 - http://hoshizaki.europe.com/			

HOSHIZAKI

PREMIER UNDERCOUNTER



Varumärke			HOSHIZAKI			
Modellnamn			PREMIER F 3 A DL DL DR	PREMIER K/M 3 A DL DL DR	PREMIER K/M 3 A 2D 2D 2D	PREMIER K/M 3 A 3D 3D 3D
Avsedd användning			Storage	Storage	Storage	Storage
Drifttemperatur vid kylning				X	X	X
Drifttemperatur vid frysning			X			
Skåp för flera användningsområden						
Vertikalt skåp						
Bänkskåp			X	X	X	X
Parameter	Symbol	Unit				
Energieffektivitetsklass	EEC	-	C	A	A	A
Energieffektivitetsindex	EEl	-	47,98	18,77	21,29	22,02
24 timmars energiförbrukning	E24h	kWh	5,340	1,299	1.438	1.438
Årlig energiförbrukning	AEC	kWh	1949	474	525	525
Nettovolyum för fack 1	Vn1	litre	96	96	88	77,5
Nettovolyum för fack 2	Vn2	litre	96	96	88	77,5
Nettovolyum för fack 3	Vn3	litre	96	96	88	77,5
Nettovolyum för fack 4	Vn4	litre	-	-	-	-
Total nettovolyum	VnT	litre	288	288	264	232
Klimatklass	CC		5	5	5	5
Köldmedium			R290	R290	R290	R290
Laddning		kg	0.055	0.065	0.065	0.065
GWP			3	3	3	3
CO2-ekvivalent		CO ₂	0,165	0,195	0,195	0,195
Tålig, den här apparaten är avsedd för användning i omgivningstemperaturer upp till 40 °C			X	X	X	X
Kontaktuppgifter:	HOSHIZAKI EUROPE B.V.					
	Address: Burgemeester Stramanweg 101 1101 AA Amsterdam, The Netherlands Tel.: +31 (0)20 691 84 99 - http://hoshizaki.europe.com/					

HOSHIZAKI

PREMIER UNDERCOUNTER



Varumärke			HOSHIZAKI			
Modellnamn			PREMIER F 4 A DL DL DR DR	PREMIER K/M 4 A DL DL DR DR	PREMIER K/M 4 A 2D 2D 2D 2D	PREMIER K/M 4 A 3D 3D 3D 3D
Avsedd användning			Storage	Storage	Storage	Storage
Drifttemperatur vid kylning				X	X	X
Drifttemperatur vid frysning			X			
Skåp för flera användningsområden						
Vertikalt skåp						
Bänkskåp			X	X	X	X
Parameter	Symbol	Unit				
Energieffektivitetsklass	EEC	-	C	A	A	A
Energieffektivitetsindex	EEL	-	44,77	17,37	21,87	22,79
24 timmars energiförbrukning	E24h	kWh	5,67	1,319	1,612	1,612
Årlig energiförbrukning	AEC	kWh	2070	481	588	588
Nettovoly m för fack 1	Vn1	litre	96	96	88	77,5
Nettovoly m för fack 2	Vn2	litre	96	96	88	77,5
Nettovoly m för fack 3	Vn3	litre	96	96	88	77,5
Nettovoly m för fack 4	Vn4	litre	96	96	88	77,5
Total nettovoly m	VnT	litre	384	384	352	310
Klimatklass	CC		4	5	4	4
Köldmedium			R290	R290	R290	R290
Laddning		kg	0.055	0.065	0.065	0.065
GWP			3	3	3	3
CO2-ekvivalent		CO ₂	0,165	0,195	0,195	0,195
Tålig, den här apparaten är avsedd för användning i omgivningstemperaturer upp till 40 °C				X		
Kontaktuppgifter:	HOSHIZAKI EUROPE B.V.					
	Address: Burgemeester Stramanweg 101 1101 AA Amsterdam, The Netherlands Tel.: +31 (0)20 691 84 99 - http://hoshizaki.europe.com/					



PREMIER UNDERCOUNTER

II. ANVÄNDNINGSSINSTRUKTIONER

ELEKTRICITET

Innan du ansluter produkten till elnätet ska du kontrollera att strömförsörjningen som anges på produktdekalen motsvarar det lokala nätets strömförsörjning.

Produktdekalen som anger strömförsörjningen finns på insidan av skåpet, längst upp till vänster.

Produkten får bara installeras av kvalificerad och utbildad servicepersonal i enlighet med specifikationerna i den här handboken.

Elsäkerheten i skåpen gäller bara om det är jordat i enlighet med gällande lokala lagar och föreskrifter.

Produkten måste alltid jordas.

Tillverkaren ansvarar inte för skador som uppstår till följd av felaktig jordning.

Följ alla krav som anges i lokala elföreskrifter. Produktens elkontakt och vägguttag måste ha rätt märkvärde för jordanslutning. Anlita vid behov en behörig elektriker.

ALLMÄNNA INLEDANDE KONTROLLER

Se till att skåpet står upprätt på ett plant underlag. Vid behov kan skåpets fötter justeras. Alla fötter ska vara i kontakt med underlaget. Det krävs för att skåpdörren ska fungera.

Placera inte skåpet bredvid enheter som alstrar värme, till exempel ugnar, grillar och fritöser. Utsätt det inte för direkt solljus. Värme som kan utstrålas av väggar eller golv måste isoleras med lämpligt isoleringsmaterial. Skåpet ska placeras så långt som möjligt från alla värmekällor.

Om skåpet måste flyttas ska du vänta i tre timmar innan du startar om det. Plastsydd eller tejp ska tas bort från utsidorna.

Se till att skåpet är placerat så att tillräckligt med frisk luft kan strömma till/från kylkretsen och runt skåpets ytor. Lämna minst 500 mm fritt utrymme från skåpets ovansida.

Om två kylskåp eller frysar ska placeras sida vid sida bör det finnas minst 50 mm utrymme mellan dem.

Täpp inte för ventilationshålen.

INLEDANDE ELEKTRISKA KONTROLLER

- e. Kontrollera att nätspänningen och frekvensen i uttaget överensstämmer med informationen på produktdekalen.
- f. Skåpet är seriellt anslutet till ett eluttag med en 13–16 A-säkring.
- g. Stäng av nätsäkringen som är ansluten till strömkabeln.
- h. Kontrollera att kontakten på skåpet är lämplig för användning med det tillgängliga eluttaget och att de passar ihop.

PREMIER UNDERCOUNTER

INLEDANDE ÅTGÄRDER OCH KONTROLLER

När kontrollerna ovan har slutförts kan skåpet användas. Skåpet styrs med PÅ/AV-knappen.

Kompressorn börjar arbeta när skåpet har slagits PÅ. Kompressorn går tills den fabriksinställda temperaturen har nåtts. Matvaror bör inte placeras i skåpet förrän temperaturinställningen har justerats för att passa matvarorna som ska kylas.

En ny temperatur kan ställas in via styrenheten så som beskrivs i den här handboken.



VIKTIGT

- Låt produkten svalna till den inställda temperaturen innan du lägger in matvaror.
- Överskrid aldrig den maximala kapaciteten. Den maximala hyllkapaciteten är 40 kg jämnt fördelat på hyllor i stående skåp och 20 kg på hyllor och i lådor i bänkskåp.
- Se avsnittet Allmänna inledande kontroller i den här handboken för information om hur mycket utrymme som krävs för god ventilation runt produkten.
- Förvara inte explosiva ämnen som sprejflaskor med lättantändligt drivmedel i apparaten.
- För 1/3 låda kan Behållarlock med tätningstrustning inte användas.

VARNING:

- Täck aldrig för ventilationsöppningarna på apparaten.
- Använd inte mekaniska enheter eller andra medel för att skynda på avfrostningsprocessen om inte sådana rekommenderas av tillverkaren.
- Skada inte kylkretsen.
- Använd inte elektriska apparater inuti skåpet.
- Vær forsiktig så du ikke skader strøm-kabelen, ledningene eller komponentene

FÖRVARINGSFÖRHÅLLANDEN OCH PRESTANDA

Rätt förvaringsförhållanden är inte bara av största vikt för livsmedelshygien och livsmedelssäkerhet, utan också för att förbättra kvaliteten och minska energiförbrukningen. Bästa prestanda kan uppnås om följande tips och riktlinjer följs: förvara bara matvaror på hyllor, placera aldrig matvaror på skåpets golv. Matvaror ska placeras i skåpet eller bänkskåpet på ett sådant sätt att luftflödet runt omkring är bra och det finns utrymme mellan varorna och produktens väggar. Hyllavståndet kan justeras därefter om det behövs.

PREMIER UNDERCOUNTER

III. KONTROLLPANEL



➤ FUNKTIONER PÅ FRONTPANELEN

När du vill låsa knapparna på frontpanelen håller du AUX (3) och På/Standby (1) intryckta i 2 sekunder: "Loc" visas på skärmen när knapparna är låsta och "UnL" visas när de inte är det.

- 1) Enheten öppnas eller stängs när du håller **PÅ/STANDBY** intryckt i 4 sekunder. (På/Av)
- 2) **MANUELL AVFROSTNING**: Manuell avfrostning startar om knappen hålls intryckt i 4 sekunder. Manuell avfrostning startar inte om hög kylning är aktivt och förångarens temperatur inte är lämplig.
- 3) **NED**-knapp: Rullar ned på menyn eller minskar värden. Superkylning aktiveras om den hålls intryckt i 4 sekunder. När hög kylning är aktivt kan den inställda temperaturen minskas. Tiden och temperaturen avgörs med hjälp av parametrarna. Enheten avfrostas aldrig när funktionen för hög kylning är aktiverad.
- 5) **UPP**-knapp: Rullar upp på menyn eller ökar värden. Funktionen för låg och hög relativ luftfuktighet i procent aktiveras om den hålls intryckt i 4 sekunder. (På vissa modeller) "rhL" visas på skärmen när en funktion för låg relativ luftfuktighet i procent används och "rhH" visas på skärmen när en funktion för hög relativ luftfuktighet i procent används. Funktionerna visas på skärmen i 10 sekunder. "----" visas på skärmen i 1 sekund om luftfuktighetsreglering inte är tillgängligt.
- 6) **SET**-knapp: matar in och ändrar justerbara värden.

➤ ANVÄNDNING

Exempel på användning anges nedan:

"På"-status: (Ström matas och enheten är igång.)

"Standby"-status: (Enheten är avstängd men ström matas fortfarande.)

"Av"-status: Stäng av enheten genom att dra ut kontakten ur uttaget eller genom att stänga av huvudsäkring.



IV. UNDERHÅLLSANVISNINGAR

Enheten måste rengöras regelbundet. Intervallen beror på användning och graden av nedsmutsning (minst årligen).



Innan du utför rengöring eller underhåll ska du koppla från enheten



Vidrör inte eller blöt inte ned delarna i maskinutrymmet. Det kan leda till fel eller haveri.



Rengör inte plastdelarna i vatten med en temperatur över 40 °C eller i en diskmaskin för att undvika eventuella skador.

Skåpets insida och utsida samt hyllor



Rengör insidan och utsidan minst en gång i veckan för hygienisk användning.



Rengör insidan och utsidan på skåpet med en mjuk trasa som fuktats i kallt eller varmt vatten som innehåller lämplig mängd neutralt rengöringsmedel och som vridits ur. Använd inte en vattenstråle för att rengöra maskinutrymmet.



Andra kemiska medel än neutrala rengöringsmedel kan orsaka skador på insidan och utsidan.



Kvarvarande rengöringsmedel skadar metall- och plastytor. Torka av det med en mjuk trasa fuktad i varmt vatten.



Använd inte följande artiklar eftersom de kan skada lackade ytor och plastytor:

- Polermedel, alkohol, thinner, bensen, sura eller basiska rengöringsmedel, hett vatten, olja, tvålpulver, stålull eller metallborstar osv. samt i synnerhet rengöringsmedel avsedda för att avlägsna fett på fläktar och mikrovågsugnar

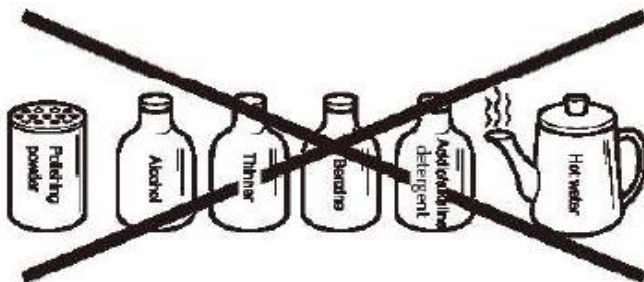

Obs! Andra lösningsmedel än de som anges ovan kan också skada lackade ytor eller plastytor. Sluta omedelbart att använda sådana lösningsmedel om de orsakar problem!

PREMIER UNDERCOUNTER



Dörrpackningen och dess kontaktyta blir lätt smutsiga. Rengör ytorna på dessa delar noggrant. Matrester påskyndar åldrandet.



Använd en trasa för att torka bort eventuellt vatten som finns kvar inuti skåpet.

Kondensor



Använd en dammsugare eller en mjuk borste för att ta bort damm och fläckar från kondensorn.

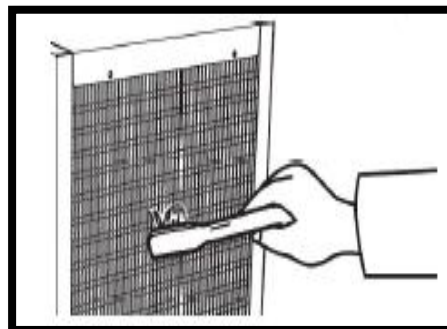

Varning: **Om användaren rengör kondensorn med en hård borste, som en diskborste, kan kondensorns beläggning lossna.**

Luftfilter



För att förhindra deformation ska luftfiltret inte tvättas i hett vatten över 40 °C



Luftfilter av plast avlägsnar smuts och damm från luften och förhindrar att kondensorn täpps till. Om luftfiltren täpps till försämras kylskåpets/frysens prestanda.



Kontrollera filtren minst två gånger i månaden. Tvätta filtren med varmt vatten och ett neutralt rengöringsmedel om de är tilltäppta eller temperaturregulatorn visar "CH". Använd inte enheten med luftfiltren borttagna, det täpper till kondensorn vilket leder till fel.

- 1) Öppna frontpanelen och ta bort luftfiltret. Rör inte vid kondensorns flänsar för att undvika skador.
- 2) Tvätta luftfiltret noggrant med kallt eller varmt vatten som innehåller rätt mängd neutralt rengöringsmedel. Skölj och torka luftfiltret noggrant.
- 3) Montera tillbaka luftfiltret genom att föra in de två tungorna på värmeväxlaren eller flänsarna i kondensorn och fäst luftfiltret ordentligt över kondensorn.

PREMIER UNDERCOUNTER

V. TEKNISK INFORMATION

ENHETERNAS MÅTT

PREMIER K-M-F 2 A DL DR L

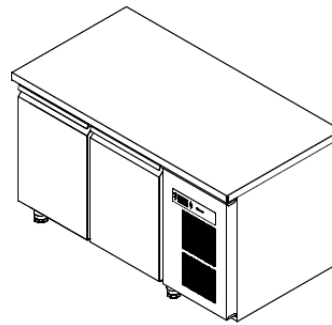
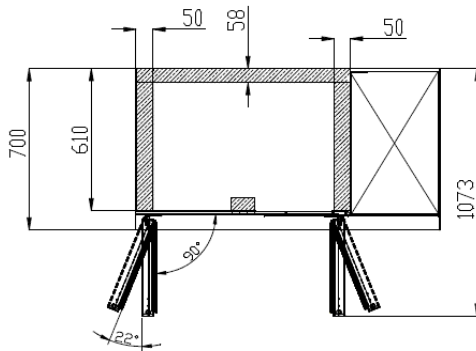
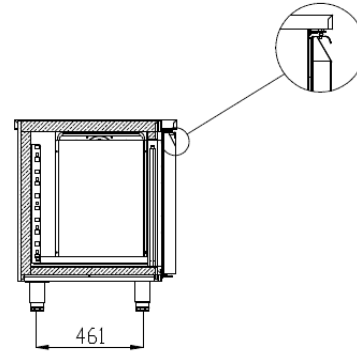
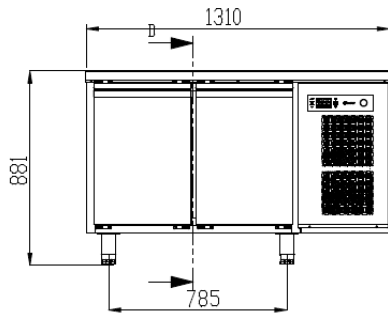

PREMIER K-M-F 2 A DL DR C

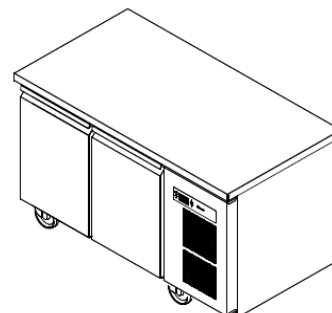
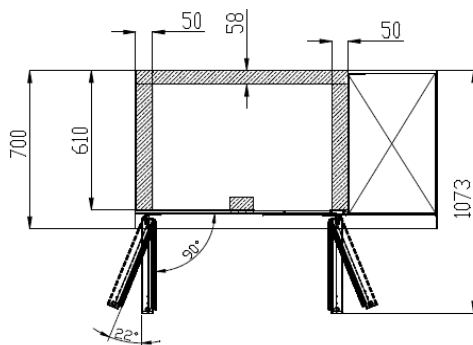
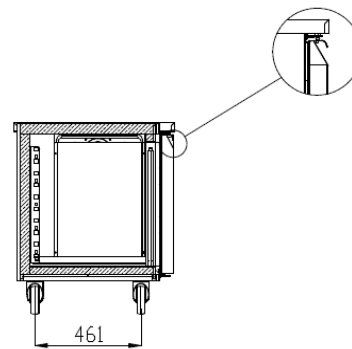
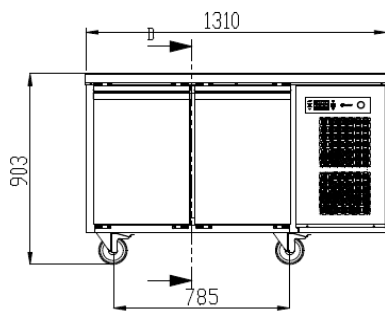

HOSHIZAKI

PREMIER UNDERCOUNTER



PREMIER K-M 2 A 2D 2D L

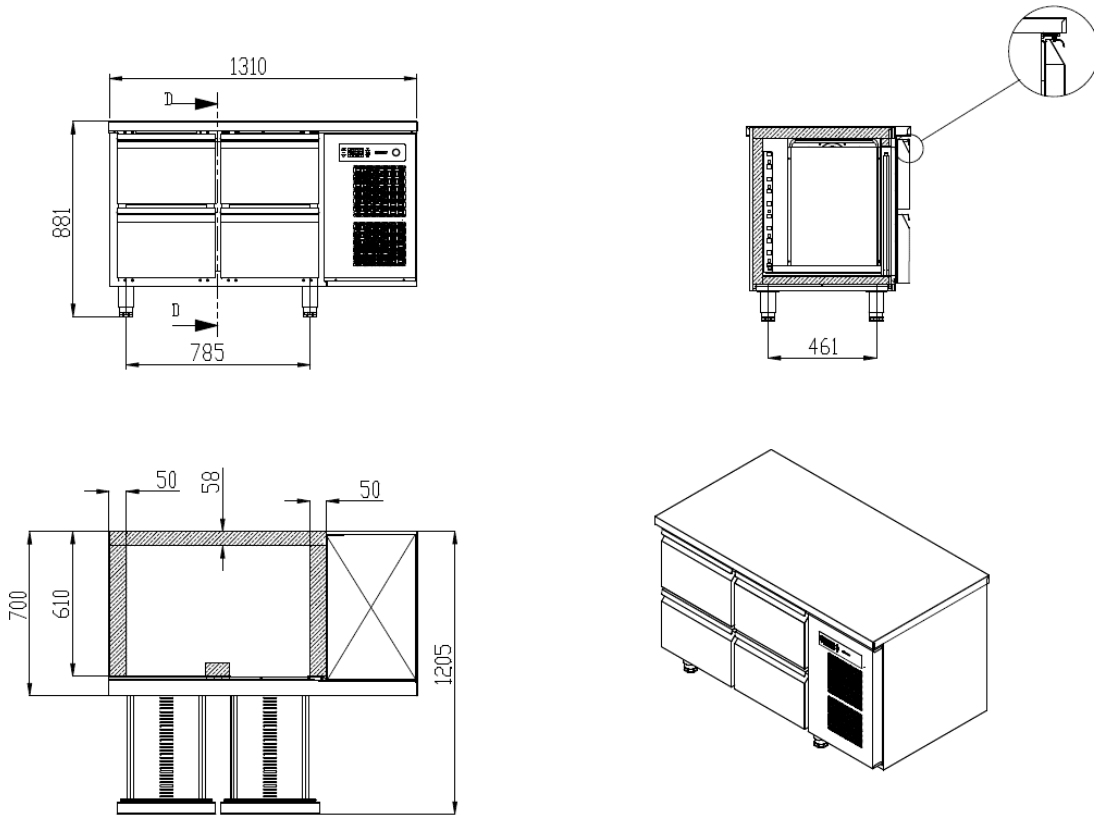

PREMIER K-M 2 A 2D 2D C

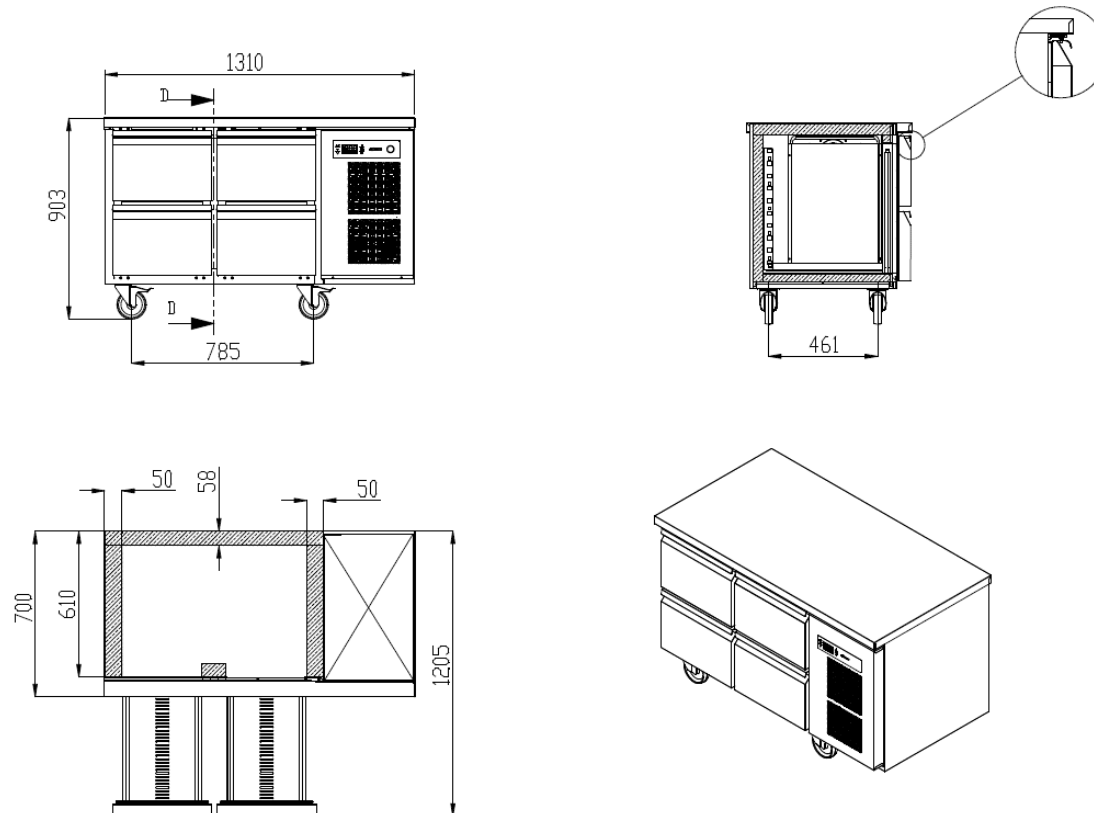

HOSHIZAKI

PREMIER UNDERCOUNTER



PREMIER K-M 2 A 3D 3D L

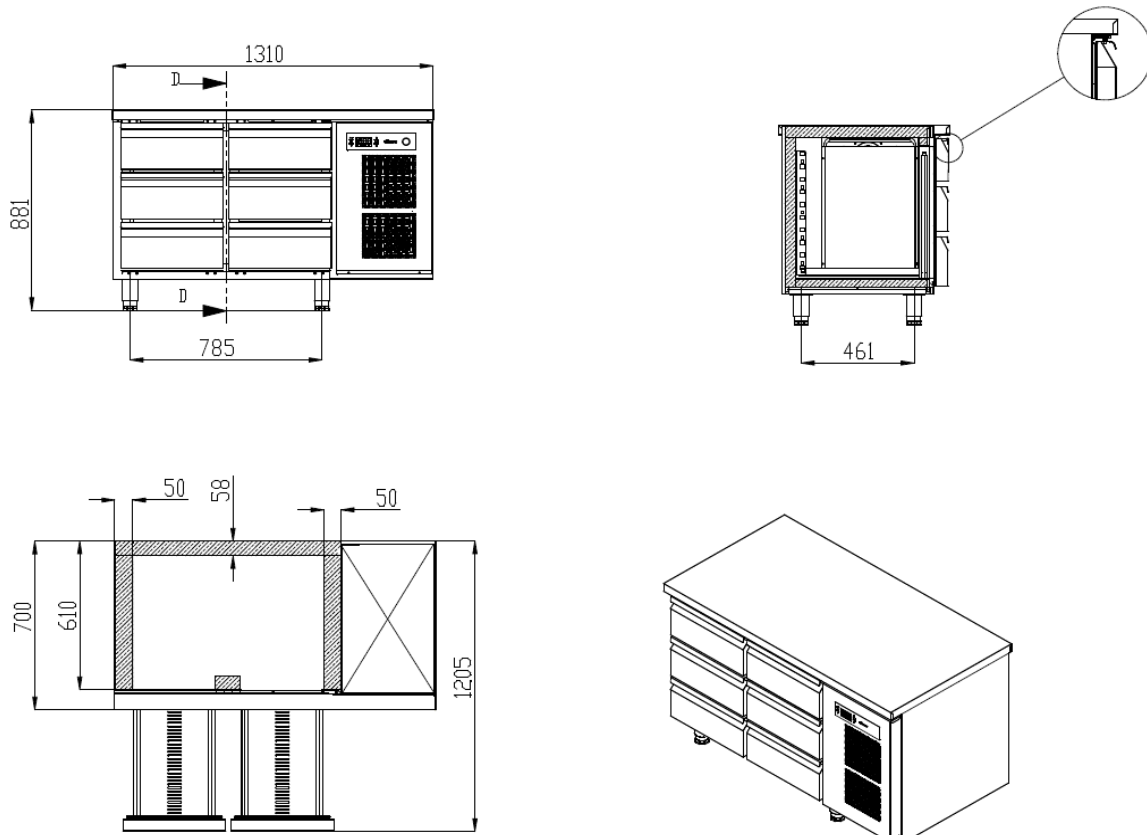

PREMIER K-M 2 A 3D 3D C

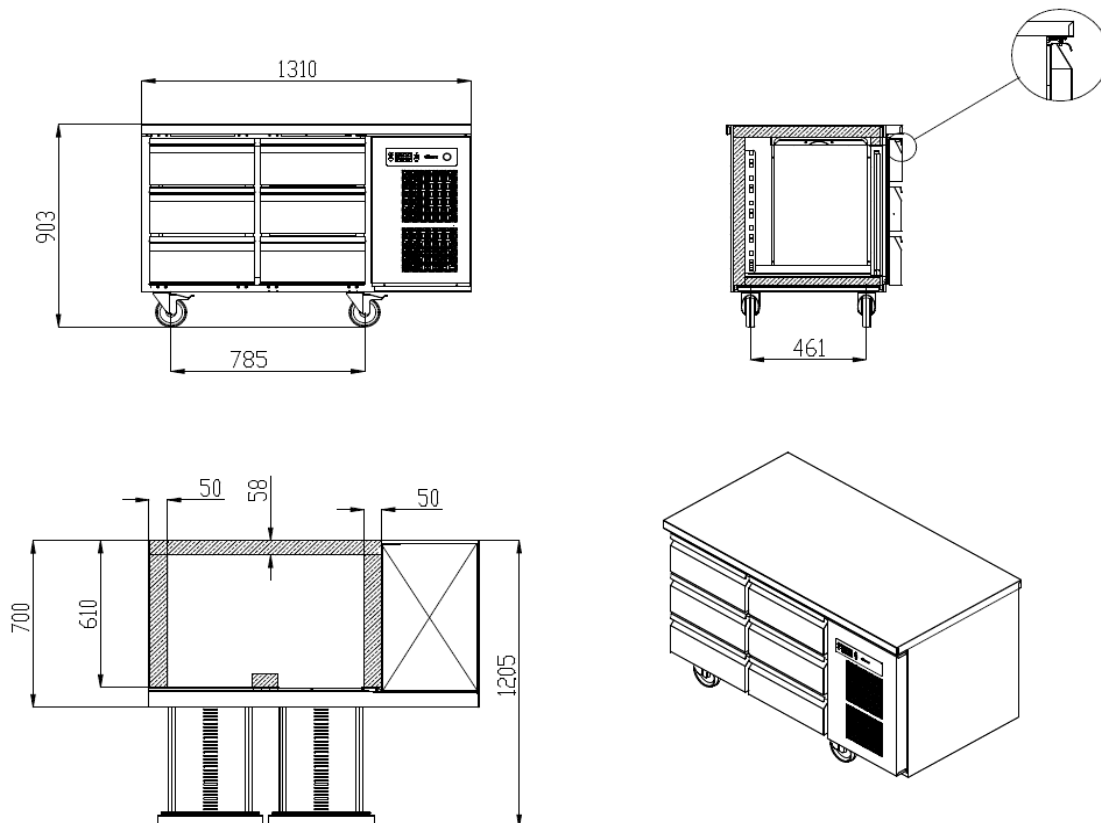

HOSHIZAKI

PREMIER UNDERCOUNTER



PREMIER K-M-F 3 A DL DR DR L

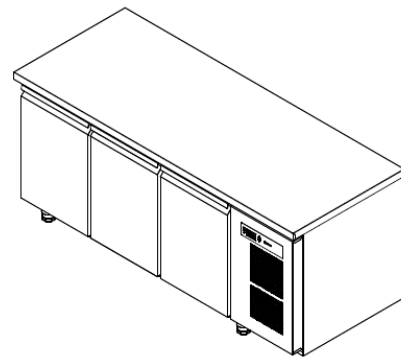
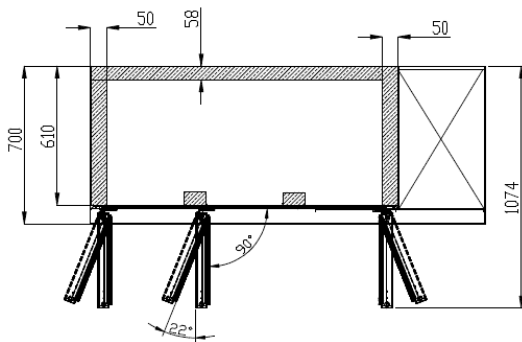
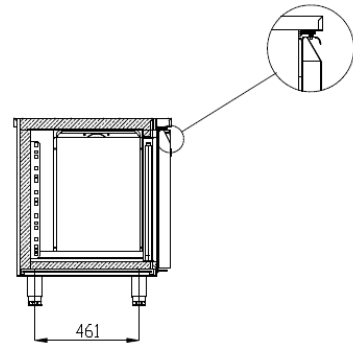
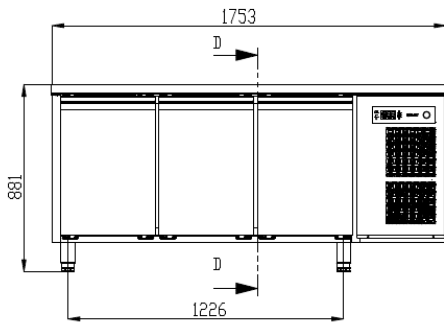

PREMIER K-M-F 3 A DL DR DR C

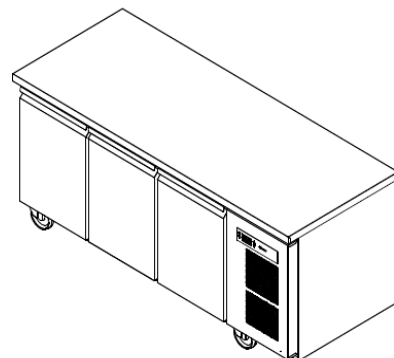
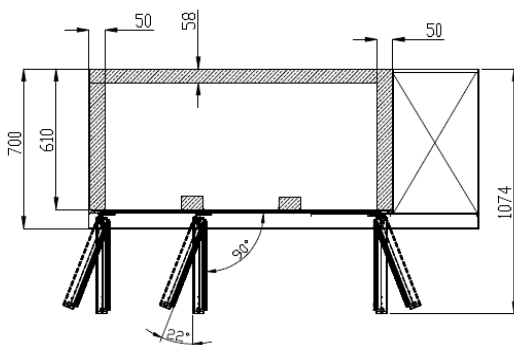
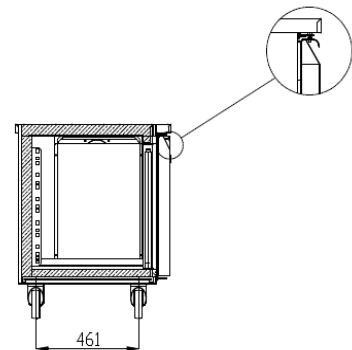
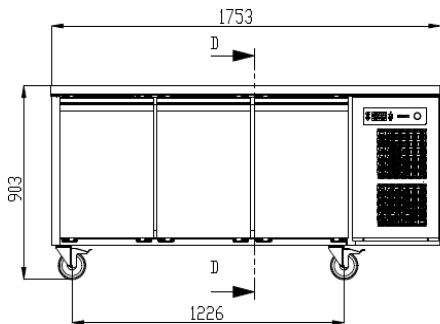

HOSHIZAKI

PREMIER UNDERCOUNTER



PREMIER K-M 3 A 2D 2D 2D L

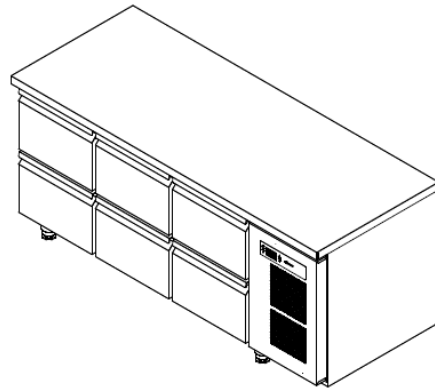
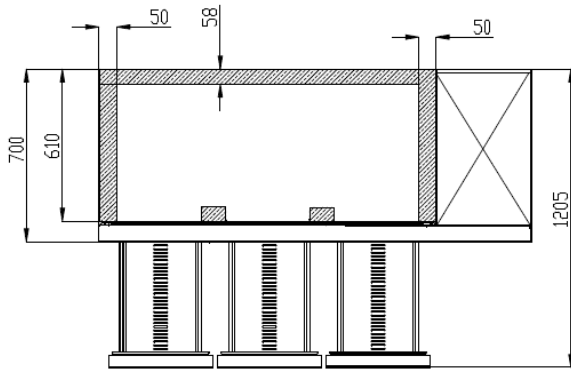
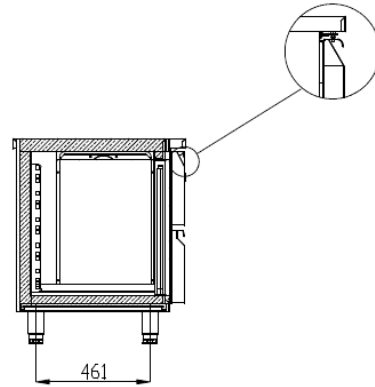
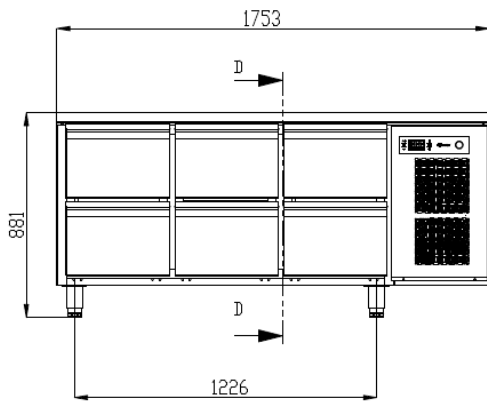

PREMIER K-M 3 A 2D 2D 2D C

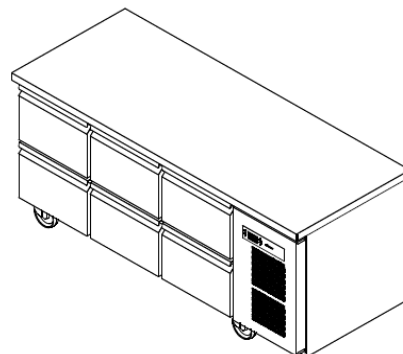
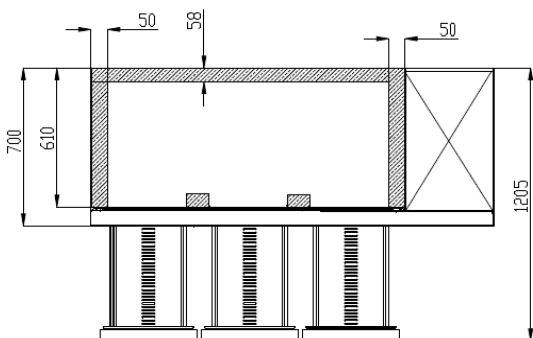
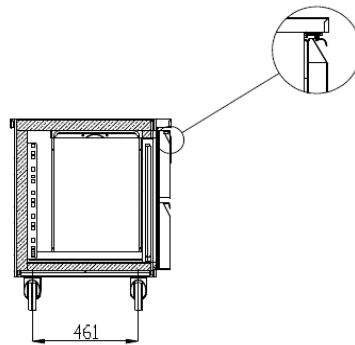
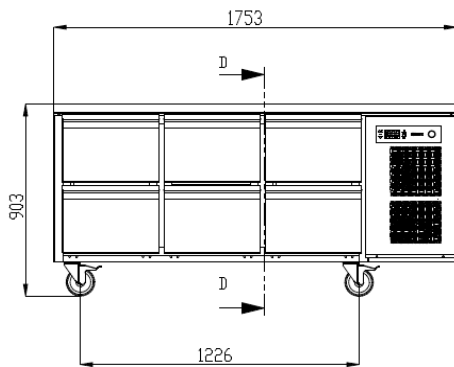

HOSHIZAKI

PREMIER UNDERCOUNTER



PREMIER K-M 3 A 3D 3D 3D 3 L

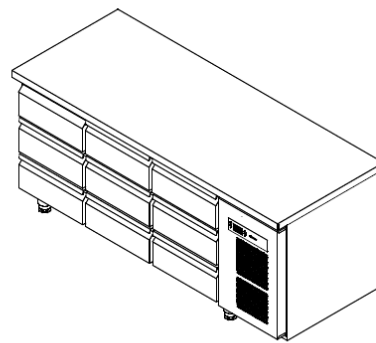
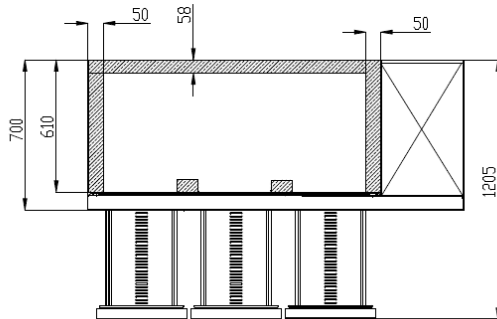
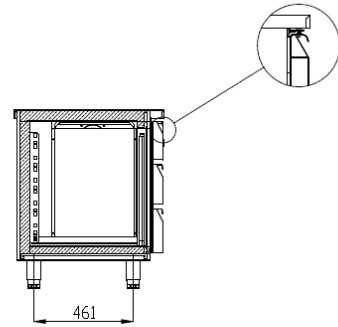
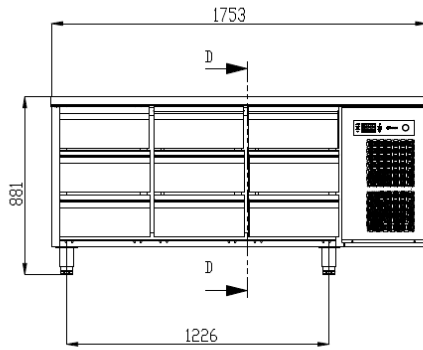

PREMIER K-M 3 A 3D 3D 3D 3 C

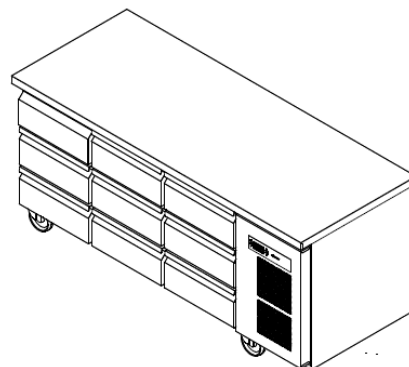
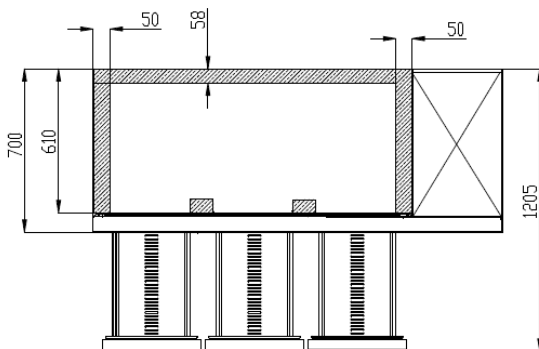
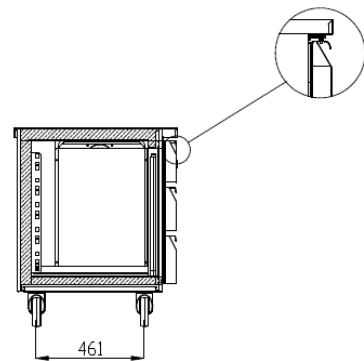
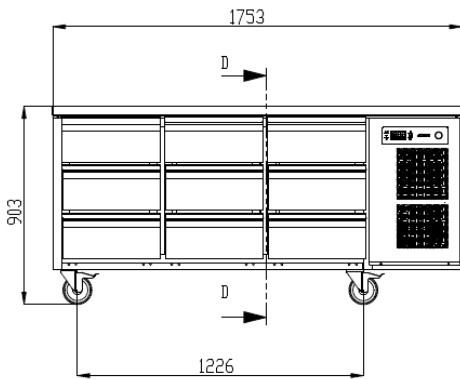

HOSHIZAKI

PREMIER UNDERCOUNTER



PREMIER K-M-F 4 A DL DL DR DR L

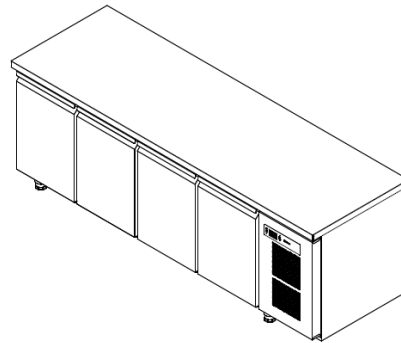
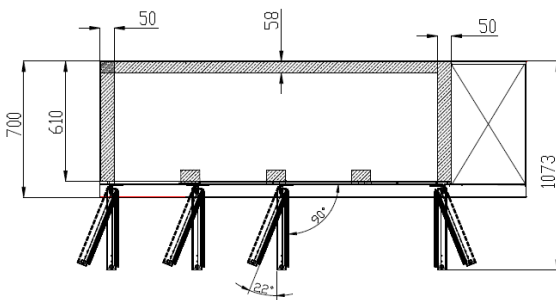
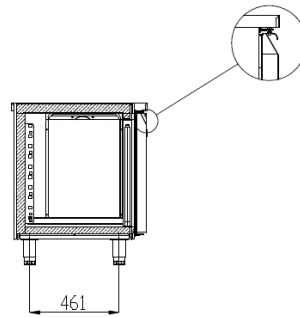
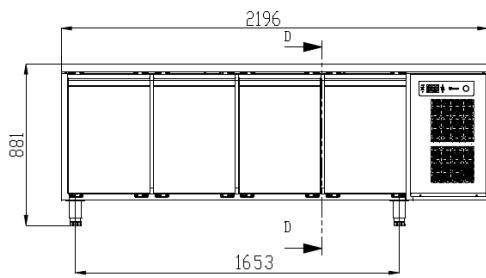

PREMIER K-M-F 4 A DL DL DR DR C

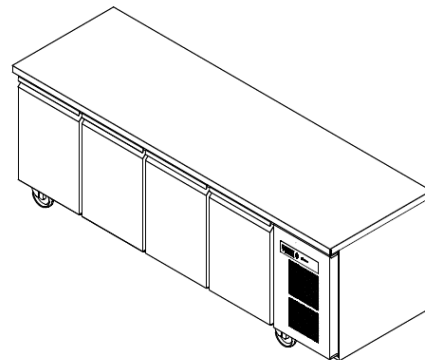
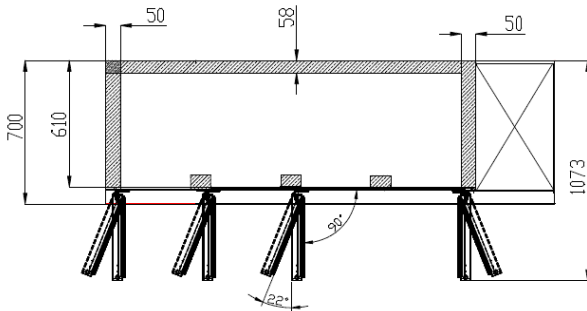
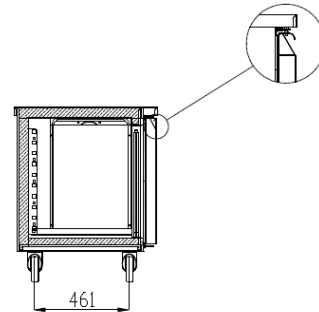
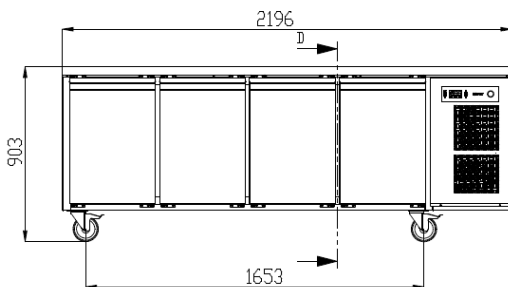

HOSHIZAKI

PREMIER UNDERCOUNTER



PREMIER K-M 4 A 2D 2D 2D 2D L

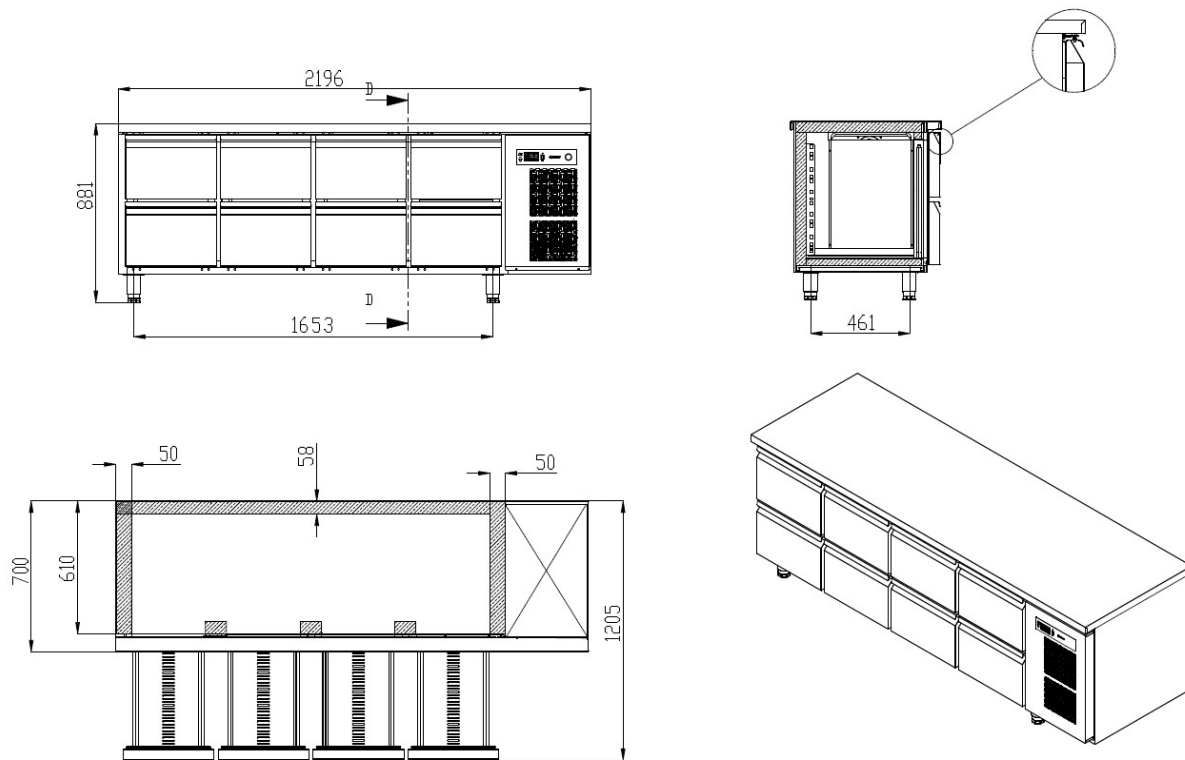

PREMIER K-M 4 A 2D 2D 2D 2D C

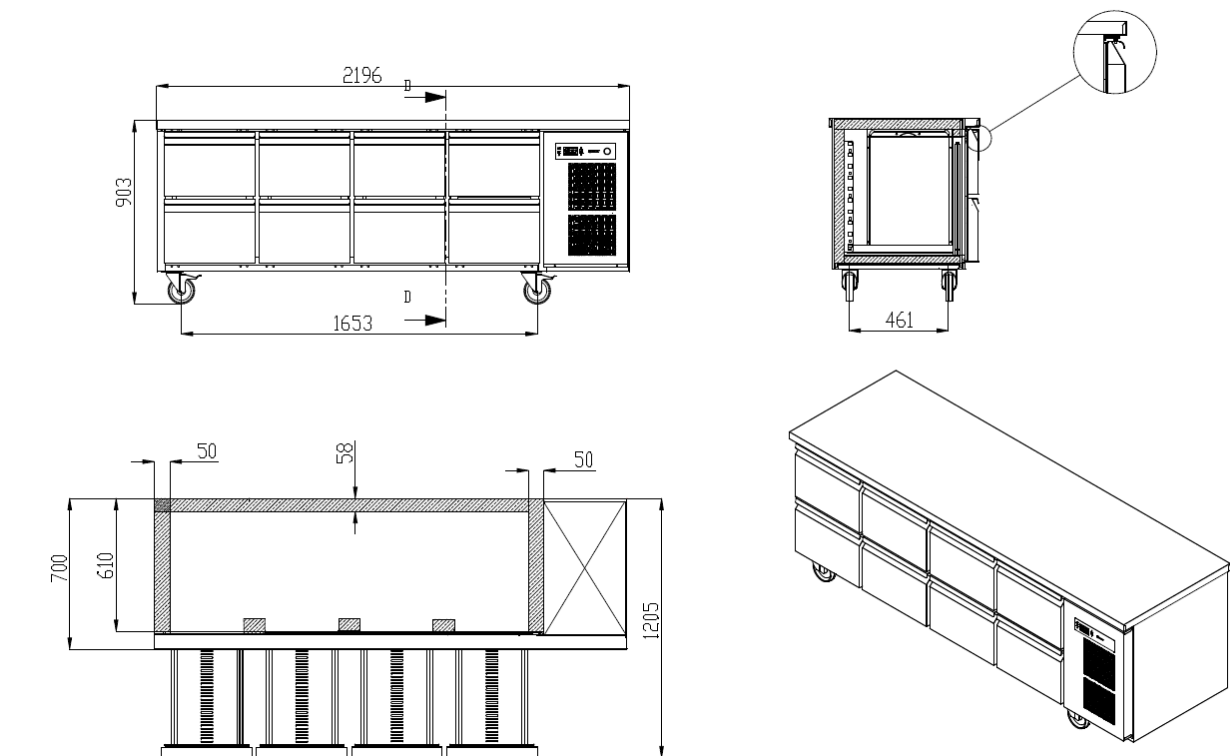



HOSHIZAKI

PREMIER UNDERCOUNTER

PREMIER K-M 4 A 3D 3D 3D 3D L

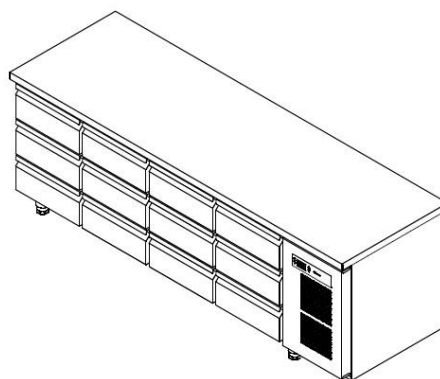
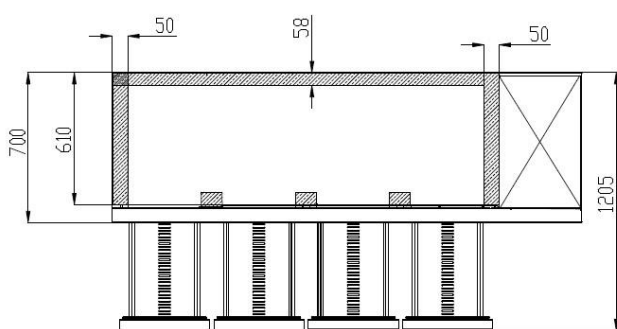
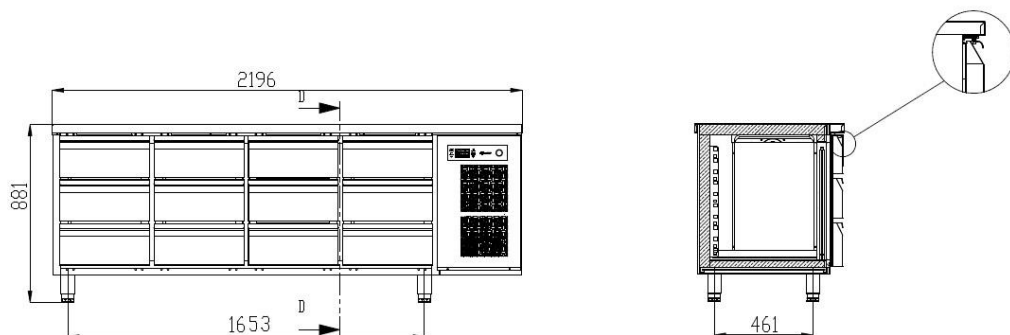

PREMIER K-M 4 A 3D 3D 3D 3D C

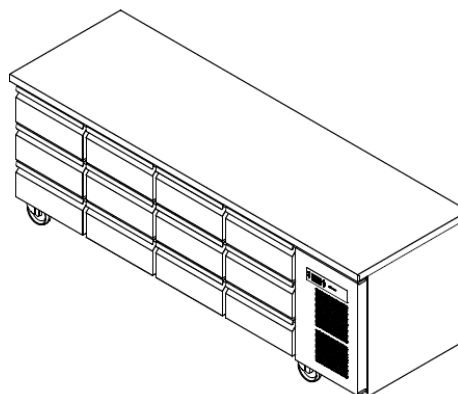
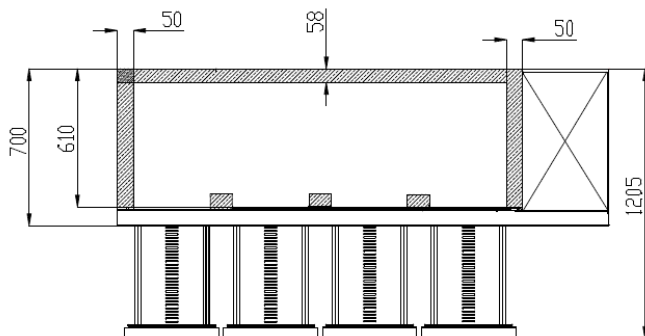
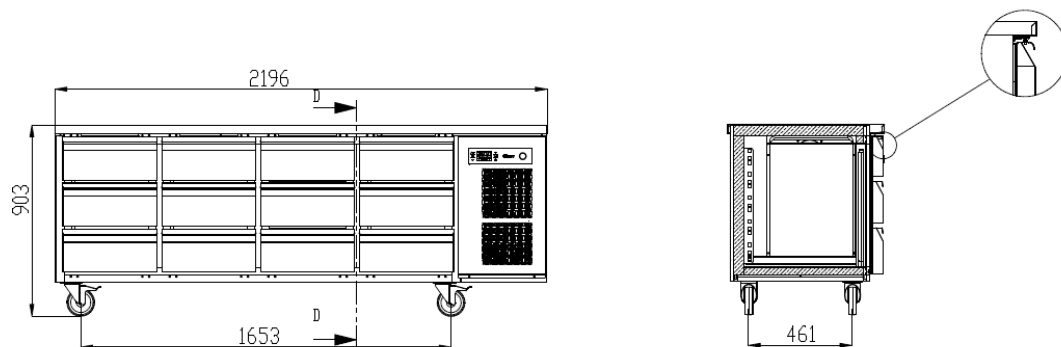

VI. KYLSHEMA - ELEKTRISKT KOPPLINGSSHEMA

HOSHIZAKI

PREMIER UNDERCOUNTER

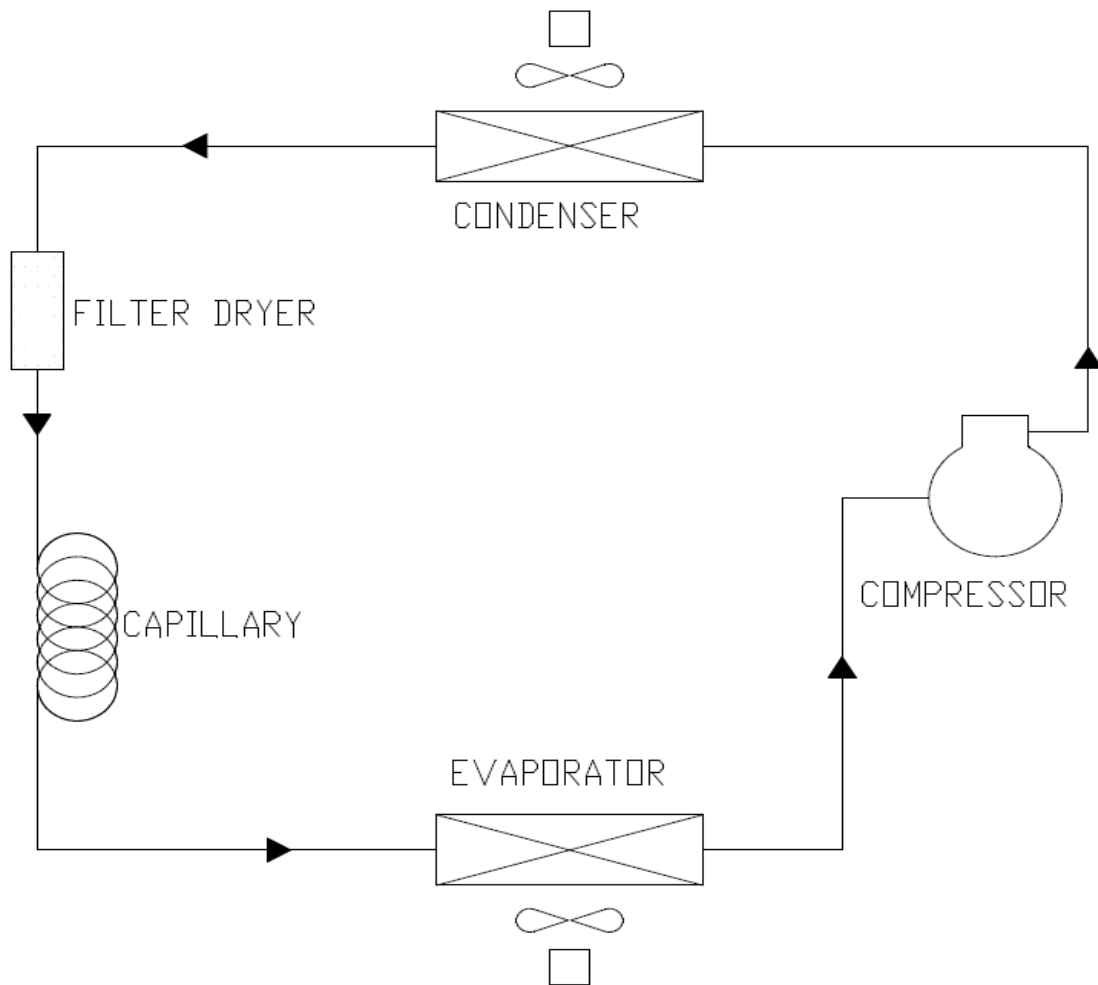



HOSHIZAKI

PREMIER UNDERCOUNTER

ELEKTRISKT KOPPLINGSSCHEMA

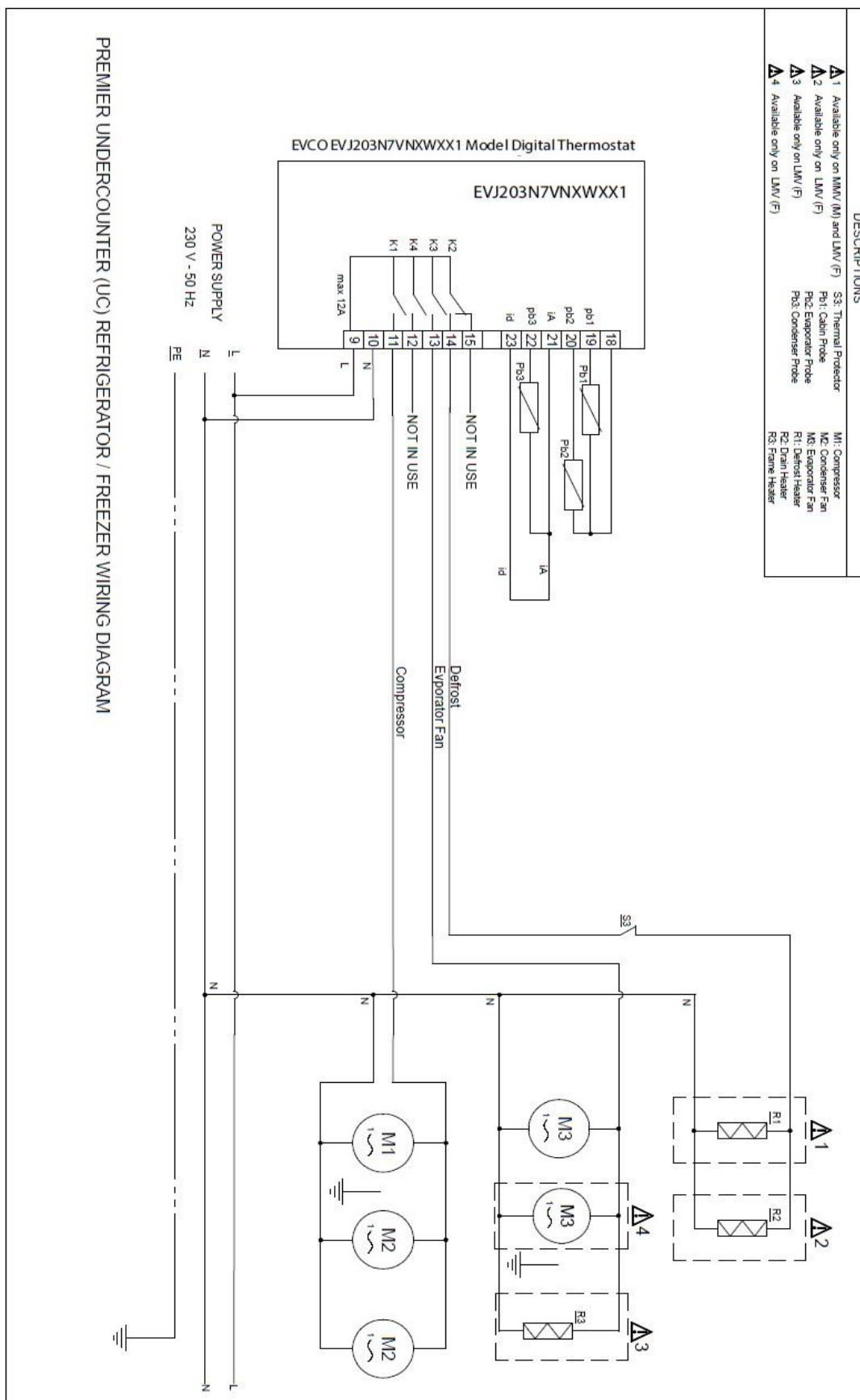

PREMIER UNDERCOUNTER

VII. SERVICEDIAGNOS

I tabellen nedan visas flera problem som kan inträffa. Om en larmkod visas har ett fel uppstått. Åtgärda eventuella orsaker innan skåpet återställs. Möjliga orsaker och åtgärder anges nedan.

Om en felkod kvarstår efter att du har utfört kontrollerna nedan kontaktar du en auktoriserad tekniker. Felmeddelandets natur måste fastställas. Produktinformation inklusive serienumret finns på produktens typskylt.

PROBLEM	MÖJLIG ORSAK	LÖSNING	
Skåpet fungerar inte	Ingen ström matas till skåpet	Kontrollera att kontakten och kabeln är felfria	
Kompressorn slutar sällan att gå	Omgivningstemperaturen är för hög	Ventilationen måste förbättras	
	Kondensorn eller kondensorfiltret är igensatt	Kontrollera och rengör kondensorfiltret regelbundet	
	Dörrpackningarna tätar inte ordentligt	Kontakta en auktoriserad tekniker för att byta tätningarna	
	Isbildning i förångaren	Placera inte varma matvaror i skåpet	Placera inte matvaror med hög vattenhalt inuti skåpet om de inte förvaras i förseglade behållare
		Starta en manuell avfrostningscykel	
Förångarens fläkt/fläktar är defekta	Kontakta en auktoriserad tekniker för att byta ut fläkten/fläktarna		
Vatten strömmar ut från kondensorns vattenbehållare	Varma matvaror placeras ofta i skåpet	Placera inte varma matvaror i skåpet Lägg endast matvaror med hög vattenhalt i förslutna behållare i skåpet	
	Dörrar eller lådor öppnas ofta	Kontrollera om skåpets specifikationer är lämpliga för den aktuella användningen	
Skåpets temperatur är hög	Kondensorn är igensatt av smuts och damm	Kontrollera och rengör kondensorfiltret regelbundet	
	Luftflödet i skåpet är blockerat	Ta bort matvaror som blockerar luftflödet	
	Omgivningsluft kommer in i skåpet	Se till att dörren är stängd	Kontrollera om dörrens och lådornas tätningar är skadade
		Kontakta en auktoriserad tekniker	
Isbildning i förångaren	Starta en manuell avfrostningscykel		

PREMIER UNDERCOUNTER

VIII. DEMONTERING OCH BYTE

KASSERING AV SKÅPET

- e. Kylgasen som finns i skåpet anges på typskylten.
- f. Skåpet är tillverkat av återvinningsbart material i enlighet med EU:s bestämmelser. Därför måste skåpet vid slutet av sin ekonomiska livslängd överlämnas till lämplig återvinningsstation för kassering.
- g. Återvinn inte skåpet som metall- eller hushållsavfall.
- h. Komprimera inte kylanläggningens kylkrets.



VIKTIGT

Följ lokala lagar och bestämmelser när skåpet kasseras.

HOSHIZAKI

PREMIER UNDERCOUNTER



Med ensamrätt. Hoshizaki förbehåller sig rätten att ändra funktioner och information i den här handboken.

Kontaktuppgifter

Huvudkontor

Hoshizaki Europe B.V – All other countries in Europe and Africa

TEL: +31 (0)20 6918499

sales@hoshizaki.nl -- <http://hoshizaki-europe.com/>

Filialer

Hoshizaki UK - UK, Ireland

TEL: +44 (0)845 456 05 85

uksales@hoshizaki.co.uk

Hoshizaki Deutschland - Germany, Switzerland, Austria

TEL: +49 (0)5121 697370

vertrieb@hoshizaki.de

Hoshizaki Benelux - Netherlands, Belgium, Luxembourg

TEL: +31 (0)85 0188370

info@hoshizaki.nl

Hoshizaki France - France

TEL: +33 (0)1 48 63 93 80

info@hoshizaki.fr

Hoshizaki Iberia - Spain, Portugal

TEL: +34 (0)93 478 09 52

info@hoshizaki.es

Hoshizaki Denmark - Denmark

TEL: +45 89 88 53 50

salg@hoshizaki.dk

Hoshizaki Norway - Norge

TEL: +47 22 88 17 50

salg@hoshizaki.no

Hoshizaki Sweden - Sverige

TEL: +46 108 84 87 47

OrderSE@hoshizaki.dk

Hoshizaki Italia – Italia

TEL: +39 348 3022156

commerciale@hoshizaki.it

HOSHIZAKI

PREMIER UNDERCOUNTER



HOSHIZAKI

PREMIER UNDERCOUNTER



KJØLESKAP OG FRYSESKAP DRIFTS-, VEDLIKEHOLDS- OG INSTALLASJONSHÅNDBOK



I. GENERELL INFORMASJON	210
II. BRUK	215
III. KONTROLLPANEL	217
IV. VEDLIKEHOLDSINSTRUKSJONER	218
V. TEKNISK INFORMASJON	220
VI. KJØLESKJEMA – ELEKTRISK KOBLINGSSKJEMA	229
VII. VEDLIKEHOLDSDIAGNOSE	231
VIII. FJERNING OG UTSKIFTING	232

Kontaktinformasjon:

HOSHIZAKI EUROPE B.V.

Adresse: Burgemeester Stramanweg 101 1101 AA Amsterdam, Nederland

Tlf.: +31 (0)20 691 8499 <http://hoshizaki-europe.com/>



PREMIER UNDERCOUNTER

I. GENERELL INFORMASJON

PRODUKTBEKRIVELSESETIKETT

1 - Produktnummer
2 - Produktbeskrivelse
3 - Modell
4 - Kjølemiddel (GWP)
5 - CO ₂ -ekvivalent
6 - IP-beskyttelse
7 - Klimaklasse
8 - Produksjonsdato
9 - Total effekt / strømstyrke / lampeeffekt
10 - Spenning – frekvens
11 - Varmeelement
12 - Systemtrykk
13 - Blåsemiddel
14 - Serienummer

PRODUCT NUMBER	1
	
PRODUCT DESCRIPTION	2
MODEL	3
REFRIGERANT	4
CO ₂ EQUIVALENT	5
IP PROTECTION	6
CLIMATE CLASS	7
PRODUCTION DATE	8
TOTAL POWER / CURRENT / LAMP POWER	9
VOLTAGE - FREQUENCY	10
HEATING ELEMENT	11
SYSTEM PRESSURE	12
BLOWING AGENT	13

S/N: 14



HOSHIZAKI EUROPE B.V. Burgemeester Stramanweg 101 1101 AA
Amsterdam, The Netherlands



BRUKSFORMÅL

- Dette skapet er kun egnet til innendørs bruk og kun til oppbevaring av mat og drikke. Oppbevaringsenhetene er konstruert for produkter som allerede har kjøle-/frysetemperatur.
- Produsenten kan ikke holdes ansvarlig for skader oppstått etter bruk som strider med retningslinjene i denne veiledningen.
- Maten må aldri komme i kontakt med skapets innvendige vegger.
- All mat skal dekkes fullstendig. All mat skal pakkes eller oppbevares i lukkede beholdere for å unngå forurensning og korrosjon på innvendige komponenter.
- Varm mat eller væske skal ikke oppbevares i skapet.
- Drikke i bokser og glassflasker bør ikke oppbevares ved temperaturer under 0 °C (frysepunktet). Bokser og glassflasker kan sprekke fordi de utvides. Beholdere med lokk skal ikke fylles helt: det skal være plass til utvidelse.
- Skapet er utstyrt med automatisk avriming. Manuell avriming er også mulig. Manuell avriming kan foretas via kontrolleren, og skapet trenger ikke være avslått i lang tid. Det må aldri brukes makt eller håndverktøy til å avrime skapet. Skader forårsaket av dette er vanskelige å reparere.
- Bruk ikke mekaniske eller andre avrimingsmetoder.
- Produktet skal ikke brukes av personer (inkludert barn) med nedsatte fysiske, sensoriske eller mentale evner, eller med manglende erfaring og kunnskap, med mindre de er under tilsyn eller instrueres.
- Barn må være under tilsyn slik at de ikke leker med produktet.
- Rengjøring og brukervedlikehold skal ikke utføres av barn uten tilsyn.

PREMIER UNDERCOUNTER

- Produktet kan brukes av barn fra åtte år og eldre og personer med nedsatte fysiske, sensoriske eller mentale evner, eller med manglende erfaring og kunnskap, hvis de er under tilsyn eller instrueres i sikker bruk av produktet og forstår hvilke farer dette medfører.
- Ved elektriske eller mekaniske modifikasjoner av skapet vil garantien ikke lenger være gyldig. Modifikasjoner utført av uautoriserte serviceteknikere og andre endringer enn de som er beskrevet i denne håndboken, vil også annullere garantien. Produsenten påtar seg intet ansvar for skader som skyldes slike modifikasjoner.

KLIMAKLASSE

Skapet er konstruert for å fungere ved spesifikke omgivelsestemperaturer og fuktighetsnivåer. Disse er spesifisert i klimaklasser. Disse nivåene skal aldri overskrides. Klimaklassen for dette skapet finner du på produktbeskrivelsesetiketten. Kjøleskapet er ikke egnet for bruk ved omgivelsestemperaturer under 16 °C.

Klimaklasse	Omgivelsestemperatur og fuktighet
4	+30 °C med 55 % relativ fuktighet
5	+40 °C med 40 % relativ fuktighet

MOTTAK OG KONTROLL

Dette skapet er pakket i beskyttende emballasjemateriale for frakt. Ved levering skal skapet kontrolleres for transportskader og at du har mottatt produktmodellen du bestilte.



VIKTIG

All bruk som er oppført nedenfor, må overholde alle lokale vedtekter og sikkerhetsforskrifter. Følg alle gjeldende sikkerhetsregler når du bruker skapet.

TRANSPORT

Når skapet løftes med maskiner, må maskinens løftekapasitet verifiseres på forhånd.



VIKTIG

Ved bruk av gaffeltruck til å flytte skapet er det viktig å kontrollere at gaflene plasseres i de riktige åpningene i pallen.

Etter flytting skal skapet plasseres stabilt. Skapet kan tippe over hvis tyngdepunktet ikke ligger i midten av skapet. Når skapet senkes ned med gaffeltruck, skal dette skje sakte og forsiktig.

Hvis et vertikalt skap må transporteres liggende, skal skapet ha vært i stående stilling i minst to timer før det slås på. Det anbefales ikke å transportere vertikale skap liggende, og skader som skyldes slik håndtering dekkes ikke av garantien.

PREMIER UNDERCOUNTER



MERK

Anbefalingene på utsiden av transportemballasjen er viktige for brukeren. Følgende anbefalinger bør derfor følges:

- Håndter skapet med forsiktighet.
- Hold skapet tørt. Bruk ikke toppen av skapet til oppbevaring!

PAKKE UT

- Fjern kartongen og annet emballasjemateriale.
- Løft skapet for å løsne og fjerne det fra pallen.
- Plasser skapet på ønsket sted slik at det står på basen.
- Se etter synlige skader.
- Emballasjematerialer kan resirkuleres i henhold til lokale forskrifter om resirkulering.
- Kontroller at produktkoden og serienummeret samsvarer med fraktdokumentene.

Varemerke			HOSHIZAKI			
Modellnavn			PREMIER F 2 A DL DR	PREMIER K/M 2 A DL DR	PREMIER K/M 2 A 2D 2D	PREMIER K/M 2 A 3D 3D
Tiltenkt bruk			Storage	Storage	Storage	Storage
Kjøletemperatur				X	X	X
Frysetemperatur			X			
Flerbruksskap						
Vertikalt skap						
Benkeskap			X	X	X	X
Parameter	Symbol	Unit				
Energieffektivitetsklasse	EEC	-	C	A+	A	A
Energieffektivitetsindeks	EEl	-	40,26	13,9	17,42	17,85
Energiforbruk per 24 timer	E24h	kWh	3,862	0,869	1,069	1,069
Energiforbruk per år	AEC	kWh	1410	317	390	390
Nettovolum for rom 1	Vn1	litre	96	96	88	77,5
Nettovolum for rom 2	Vn2	litre	96	96	88	77,5
Nettovolum for rom 3	Vn3	litre	-	-	-	-
Nettovolum for rom 4	Vn4	litre	-	-	-	-
Nettovolum totalt	VnT	litre	192	192	176	155
Klimaklasse	CC		5	5	5	5
Kjølemiddel			R290	R600a	R600a	R600a
Påfylling		kg	0.055	0.07	0.07	0.07
GWP			3	3	3	3
CO2-ekvivalent		CO ₂	0,165	0,21	0,24	0,21
Høy belastning: Dette produktet er beregnet for bruk ved omgivelsestemperaturer opptil 40 °C			X	X	X	X
Kontaktinformasjon:	HOSHIZAKI EUROPE B.V.					
	Address: Burgemeester Stramanweg 101 1101 AA Amsterdam, The Netherlands Tel.: +31 (0)20 691 84 99 - http://hoshizaki.europe.com/					

HOSHIZAKI

PREMIER UNDERCOUNTER



Varemerke			HOSHIZAKI			
Modellnavn			PREMIER F 3 A DL DL DR	PREMIER K/M 3 A DL DL DR	PREMIER K/M 3 A 2D 2D 2D	PREMIER K/M 3 A 3D 3D 3D
Tiltenkt bruk			Storage	Storage	Storage	Storage
Kjøletemperatur				X	X	X
Frysetemperatur			X			
Flerbruksskap						
Vertikalt skap						
Benkeskap			X	X	X	X
Parameter	Symbol	Unit				
Energieffektivitetsklasse	EEC	-	C	A	A	A
Energieffektivitetsindeks	EEl	-	47,98	18,77	21,29	22,02
Energiforbruk per 24 timer	E24h	kWh	5,340	1,299	1.438	1.438
Energiforbruk per år	AEC	kWh	1949	474	525	525
Nettovolum for rom 1	Vn1	litre	96	96	88	77,5
Nettovolum for rom 2	Vn2	litre	96	96	88	77,5
Nettovolum for rom 3	Vn3	litre	96	96	88	77,5
Nettovolum for rom 4	Vn4	litre	-	-	-	-
Nettovolum totalt	VnT	litre	288	288	264	232
Klimaklasse	CC		5	5	5	5
Kjølemiddel			R290	R290	R290	R290
Påfylling		kg	0.055	0.065	0.065	0.065
GWP			3	3	3	3
CO2-ekvivalent		CO ₂	0,165	0,195	0,195	0,195
Høy belastning: Dette produktet er beregnet for bruk ved omgivelsestemperaturer opptil 40 °C			X	X	X	X
Kontaktinformasjon:			HOSHIZAKI EUROPE B.V.			
			Address: Burgemeester Stramanweg 101 1101 AA Amsterdam, The Netherlands Tel.: +31 (0)20 691 84 99 - http://hoshizaki.europe.com/			

HOSHIZAKI

PREMIER UNDERCOUNTER



Varemerke			HOSHIZAKI			
Modellnavn			PREMIER F 4 A DL DL DR DR	PREMIER K/M 4 A DL DL DR DR	PREMIER K/M 4 A 2D 2D 2D 2D	PREMIER K/M 4 A 3D 3D 3D 3D
Tiltenkt bruk			Storage	Storage	Storage	Storage
Kjøletemperatur				X	X	X
Frysetemperatur			X			
Flerbruksskap						
Vertikalt skap						
Benkeskap			X	X	X	X
Parameter	Symbol	Unit				
Energieffektivitetsklasse	EEC	-	C	A	A	A
Energieffektivitetsindeks	EEl	-	44,77	17,37	21,87	22,79
Energiforbruk per 24 timer	E24h	kWh	5,67	1,319	1,612	1,612
Energiforbruk per år	AEC	kWh	2070	481	588	588
Nettovolum for rom 1	Vn1	litre	96	96	88	77,5
Nettovolum for rom 2	Vn2	litre	96	96	88	77,5
Nettovolum for rom 3	Vn3	litre	96	96	88	77,5
Nettovolum for rom 4	Vn4	litre	96	96	88	77,5
Nettovolum totalt	VnT	litre	384	384	352	310
Klimaklasse	CC		4	5	4	4
Kjølemiddel			R290	R290	R290	R290
Påfylling		kg	0.055	0.065	0.065	0.065
GWP			3	3	3	3
CO2-ekvivalent		CO ₂	0,165	0,195	0,195	0,195
Høy belastning: Dette produktet er beregnet for bruk ved omgivelsestemperaturer opptil 40 °C				X		
Kontaktinformasjon:	HOSHIZAKI EUROPE B.V.					
	Address: Burgemeester Stramanweg 101 1101 AA Amsterdam, The Netherlands Tel.: +31 (0)20 691 84 99 - http://hoshizaki.europe.com/					



PREMIER UNDERCOUNTER

II. BRUK

ELEKTRISITET

Før du kobler produktet til elektrisk strøm, må du forsikre deg om at den elektriske strømkilden som er spesifisert i produktbeskrivelsen, tilsvarer den lokale elektriske strømforsyningen.

Produktbeskrivelsesetiketten med angitt elektrisk strømkilde finner du inne i skapet øverst til venstre.

Installasjon av produktet skal kun utføres av kvalifisert og faglært servicepersonell i henhold til spesifikasjonene i denne håndboken.

Den elektriske sikkerheten til skapet er bare gyldig hvis det er jordnet i tråd med gjeldende lokale lover og forskrifter.

Produktet må alltid være jordnet.

Produsenten påtar seg intet ansvar for skader som skyldes feilaktig jording.

Alle elektriske krav som er fastsatt i lokale elektriske forskrifter, må overholdes. Produktets støpsel og stikkontakt må ha korrekt måling av jordforbindelsen. Kontakt faglært elektriker om nødvendig.

FORELØPIGE GENERELLE KONTROLLER

Kontroller at skapet står på en flat overflate og at det står oppreist. Om nødvendig kan skapet justeres med de justerbare bena. Alle bena skal være i kontakt med gulvet. Dette er nødvendig for at skapdøren skal fungere skikkelig.

Ikke plasser skapet i nærheten av varmegenererende apparater som ovner, griller og frituregryter. Må ikke utsettes for direkte sollys. Varmen som kan utstråles av vegger eller gulv, må isoleres med egnet isolasjonsmateriale. Skapet skal plasseres lengst mulig unna varmekilder.

Hvis skapet flyttes, må du vente i tre timer før du slår det på. Plastemballasje eller tape må fjernes fra utvendige flater.

Pass på at skapet plasseres slik at nok frisk luft kan strømme inn i / ut av kjølekretsen og rundt skapet. La det være minst 500 mm åpen plass over skapet.

Hvis to kjøleskap eller fryseskap skal plasseres side om side, bør det være minst 50 mm avstand mellom dem.

Ikke blokker lufteåpningene.

FORELØPIGE ELEKTRISKE KONTROLLER

- Kontroller at nettspenningen og frekvensen til stikkontakten samsvarer med informasjonen på produktbeskrivelsesetiketten.
- Skapet er koblet til en stikkontakt med 13–16 ampere sikring som seriell tilkobling.
- Slå av nettsikringen som er koblet til strømkabelen.
- Kontroller at skapets støpsel er egnet til bruk med det eksisterende strømuttaket, og at de stemmer overens.

PREMIER UNDERCOUNTER

FØRSTE GANGS BRUK OG KONTROLLER

Skapet kan tas i bruk når kontrollene over er utført. Skapet slås på og av med PÅ/AV-bryteren.

Kompressoren starter når skapet er slått PÅ. Kompressoren kjører helt til den fabrikkinnstilte temperaturen er nådd. Vent med å sette inn mat i skapet til temperaturinnstillingen er tilpasset maten som skal kjøles ned.

Ny temperaturinnstilling kan gjøres via kontrolleren som beskrevet i denne håndboken.



VIKTIG

- Vent til produktet er avkjølt til den innstilte temperaturen før du legger matvarene i det.
- Overskrid aldri maksimal mengdekapasitet. Maksimal hyllekapasitet er en jevn fordeling av 40 kg hver for hyller i vertikale skap og 20 kg for hyller og skuffer i benkeskap.
- Du finner informasjon om hvor mye plass som kreves for god ventilasjon rundt produktet, i avsnittet «Foreløpige generelle kontroller» i denne håndboken.
- Eksplosive materialer som aerosolbokser med brennbart drivmiddel, må ikke oppbevares i dette produktet.
- **Ved 1/3 skuff kan ikke Beholderlokk med forseglingsutstyr brukes.**

ADVARSEL

- Skapets lufteåpninger må aldri blokkeres.
- Ikke bruk mekaniske gjenstander eller annet for å øke farten til avisningsprosessen, annet enn med de metodene som produsenten anbefaler.
- Kjølemiddelkretsen må ikke skades.
- Bruk ikke elektriske apparater inne i skapet.

OPPBEVARINGSBETINGELSER OG YTELSE

Korrekte oppbevaringsbetingelser er ikke bare viktige for matvarehygiene og -sikkerhet, men også for å forbedre servicekvaliteten og redusere energiforbruket. Optimal ytelse kan oppnås hvis følgende tips og retningslinjer følges: Matvarer skal bare plasseres i hyllene, og aldri legges nederst i skapet. Matvarer skal plasseres i skapet ved å sikre god luftstrøm overalt, slik at det er avstand mellom matvarene og skapets innvendige vegger. Hylleavstanden kan justeres om nødvendig.



III. KONTROLLPANEL



➤ FUNKSJONER PÅ FRONTPANELET

Tastene på frontpanelet låses ved å holde inne AUX (3) og On/Stand By (1) i 2 sekunder. Teksten «Loc» vises på skjermen når tastene er låst, og de er ikke låst når teksten «UnL» vises.

- 1) Når du holder inne **ON/STAND BY** i 4 sekunder, åpnes og lukkes apparatet (på/av).
- 2) **MANUELL AVISING**-tasten: Manuell avising starter når du holder inne knappen i 4 sekunder. Manuell avising starter ikke hvis ekstra kjøling er aktivert og temperaturen i fordampere ikke er egnet.
- 3) **NED**-tasten: Bla nedover i menyen eller senk verdien. Hvis du holder inne knappen i 4 sekunder, aktiveres ekstra kjøling. Den angitte temperaturen kan ikke senkes når funksjonen for ekstra kjøling er aktivert. Tiden og temperaturen fastsettes ved hjelp av parameterne. Apparatet vil ikke avises så lenge funksjonen for ekstra kjøling er aktivert.
- 5) **OPP**-tasten: Bla oppover i menyen eller øk verdien. Holder du inne knappen i 4 sekunder, får du tilgang til prosentandelen til funksjonen for lav og høy relativ luftfuktighet. (På noen modeller) står det «rhL» på skjermen (det brukes en lav prosentandel i funksjonen for relativ luftfuktighet) eller det står «rhH» på skjermen (det brukes en høy prosentandel i funksjonen for relativ luftfuktighet). Disse funksjonene vises på skjermen i 10 sekunder. Hvis kontrollen for luftfuktighet ikke er tilgjengelig, vises «----» på skjermen i 1 sekund.
- 6) **SET**-tasten: Angi og endre tast for justerbare verdier.

➤ DRIFT

Ulike driftsstatus vises nedenfor:

«On»-status: (Kontakten står i og apparatet er slått på.)

«Stand-By»-status: (Apparatet er slått av, men kontakten står i.)

«Off»-status: Trekk ut støpselet fra stikkontakten eller slå av hovedsikringen hvis du vil slå av apparatet.

PREMIER UNDERCOUNTER

IV. VEDLIKEHOLDSINSTRUKSJONER

Apparatet må rengjøres regelmessig. Intervallene avhenger av bruken og hvor skittent apparatet er (minst én gang i året).



Trekk ut støpselet før det utføres rengjøring eller vedlikehold



Delene i maskinrommet må ikke berøres eller bli våte. Dette kan føre til feil eller maskinskade.



For å unngå skade skal plastdelene ikke rengjøres med vann over 40 °C eller i oppvaskmaskin.

Innvendig og utvendig pluss skap og hyller



Rengjør apparatet innvendig og utvendig minst én gang i uken av hygieniske årsaker.



Rengjør skapet innvendig og utvendig med en myk klut fuktet med kaldt eller varmt vann som er tilsatt en passende mengde nøytralt vaskemiddel og vridd opp. Maskinrommet må ikke rengjøres med vannstråle.



Andre kjemiske midler enn nøytralt vaskemiddel kan skade de innvendige og utvendige flatene.



Rester av vaskemiddel vil skade metall- eller plastflater. Bruk en myk klut fuktet med varmt vann til å tørke det vekk.



Følgende gjenstander kan skade lakk- eller plastflater og må ikke brukes:

- Slipepulver, alkohol, tynner, bensin, syreholdig eller basisk vaskemiddel, varmt vann, petroleum, såpepulver, metallskrubber eller -børste osv. Dette gjelder spesielt vaskemidler til å fjerne fett fra kjøkkenvifte eller mikrobølgeovn.

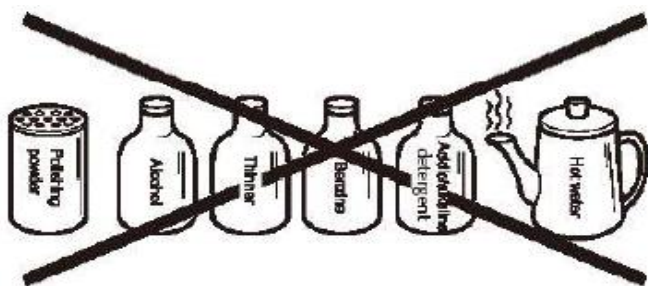

Merk: Andre midler enn ovennevnte kan også skade lakk- eller plastflater. Stans øyeblikkelig all bruk av slike midler hvis det oppstår problemer!



Dørpakningen og kontaktflatene blir lett skitne. Disse delene må rengjøres grundig. Matrester vil forringe apparatet raskere.



Vask bort vann i skapet med en klut.

PREMIER UNDERCOUNTER

Kondensator



Bruk støvsuger eller en myk børste til å fjerne støv og smuss fra kondensatoren.



Advarsel: Hvis kondensatoren rengjøres med en hard børste, for eksempel en oppvaskbørste, kan belegget på kondensatoren løsne.

Luftfilter



For å unngå deformering skal luftfilteret ikke vaskes i vann som er varmere enn 40 °C.



Luftfiltre med plastmasker fjerner smuss og støv fra luften og sørger for at kondensatoren ikke blir tett. Kjøle-/fryseskapets ytelse svekkes hvis luftfiltrene blir tette.

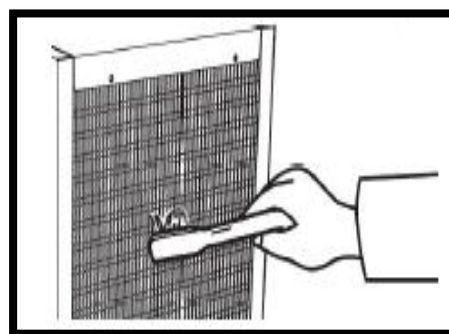

Kontroller luftfiltrene minst to ganger i måneden. Når luftfiltrene er tette eller når temperaturkontrollen viser «CH», skal du vaske filtrene med varmt vann tilsatt et nøytralt vaskemiddel. Apparatet må ikke brukes hvis luftfiltrene er fjernet. Ellers kan kondensatoren bli tett, noe som vil føre til feil.

- 1) Åpne frontpanelet og ta ut luftfilteret. For å unngå personskaade må du ikke ta direkte på kondensatorribbene.
- 2) Vask luftfilteret grundig med kaldt eller varmt vann tilsatt en passende mengde nøytralt vaskemiddel. Skyll og tørk luftfilteret godt.
- 3) Sett på plass luftfilteret ved å feste de to klaffene i varmeveksleren eller ribbene til kondensatoren, og fest luftfilteret tett over kondensatoren.



HOSHIZAKI

PREMIER UNDERCOUNTER

V. TEKNISK INFORMASJON

MÅL PÅ APPARATENE

PREMIER K-M-F 2 A DL DR L

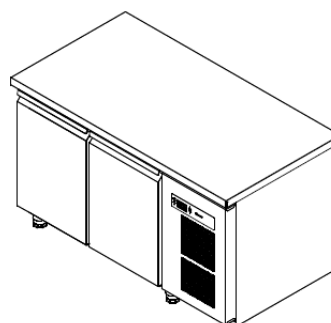
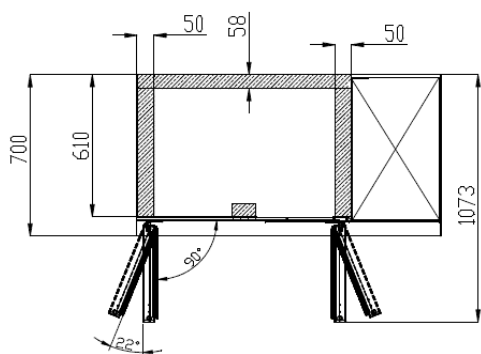
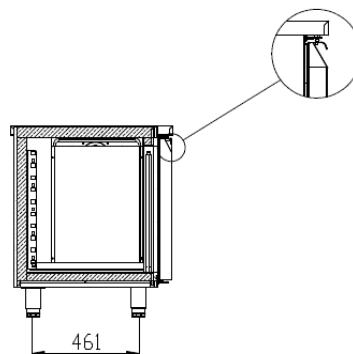
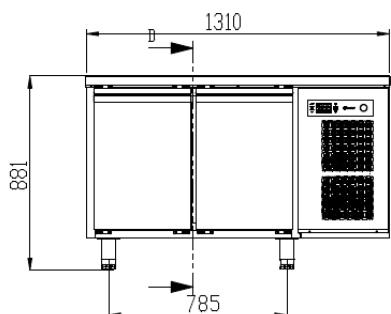

PREMIER K-M-F 2 A DL DR C

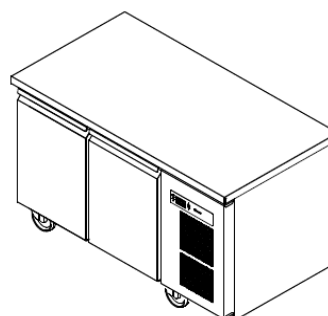
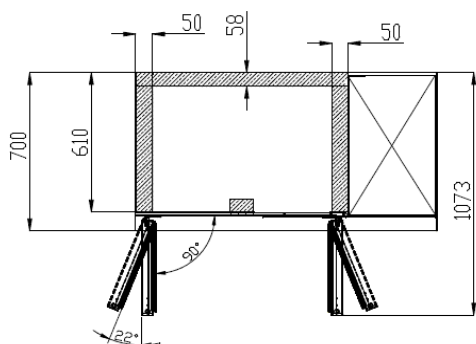
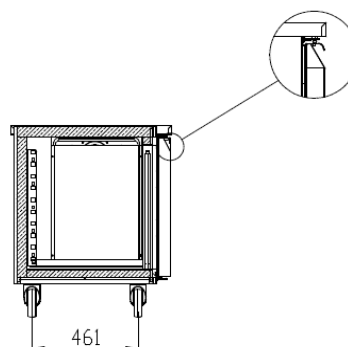
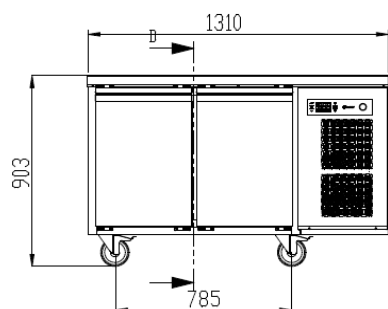

HOSHIZAKI

PREMIER UNDERCOUNTER



PREMIER K-M 2 A 2D 2D L

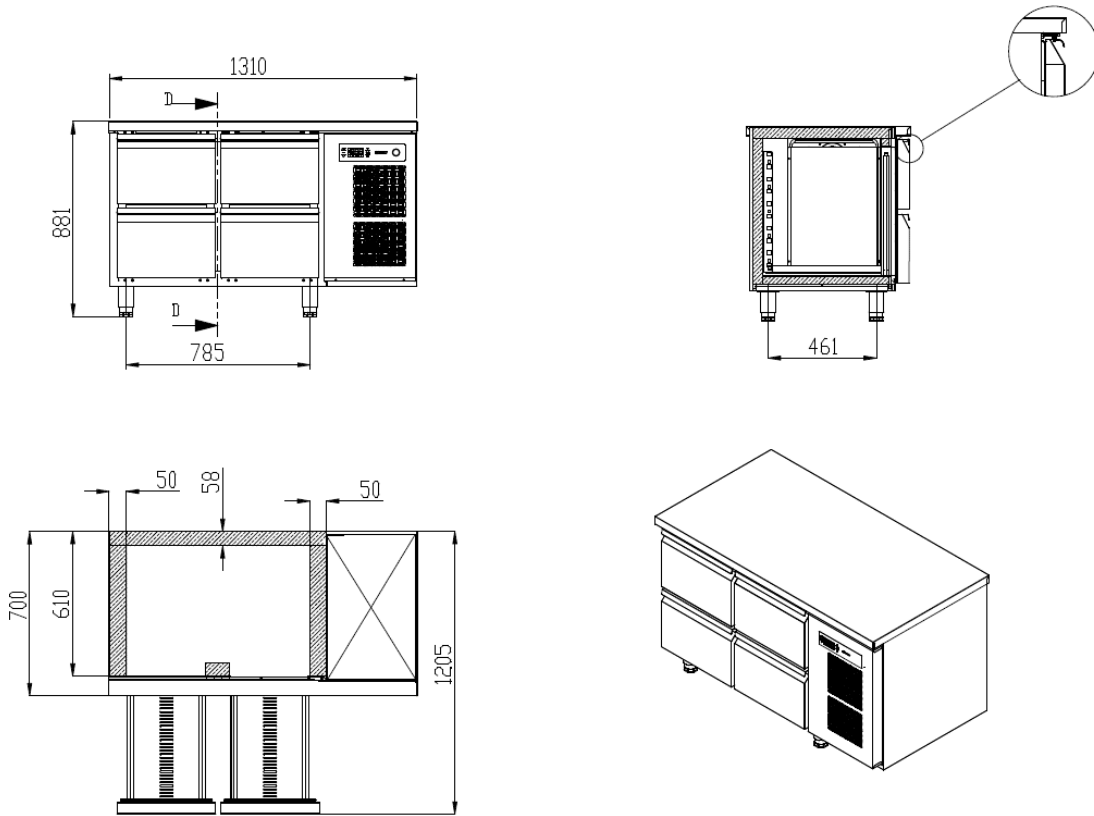

PREMIER K-M 2 A 2D 2D C

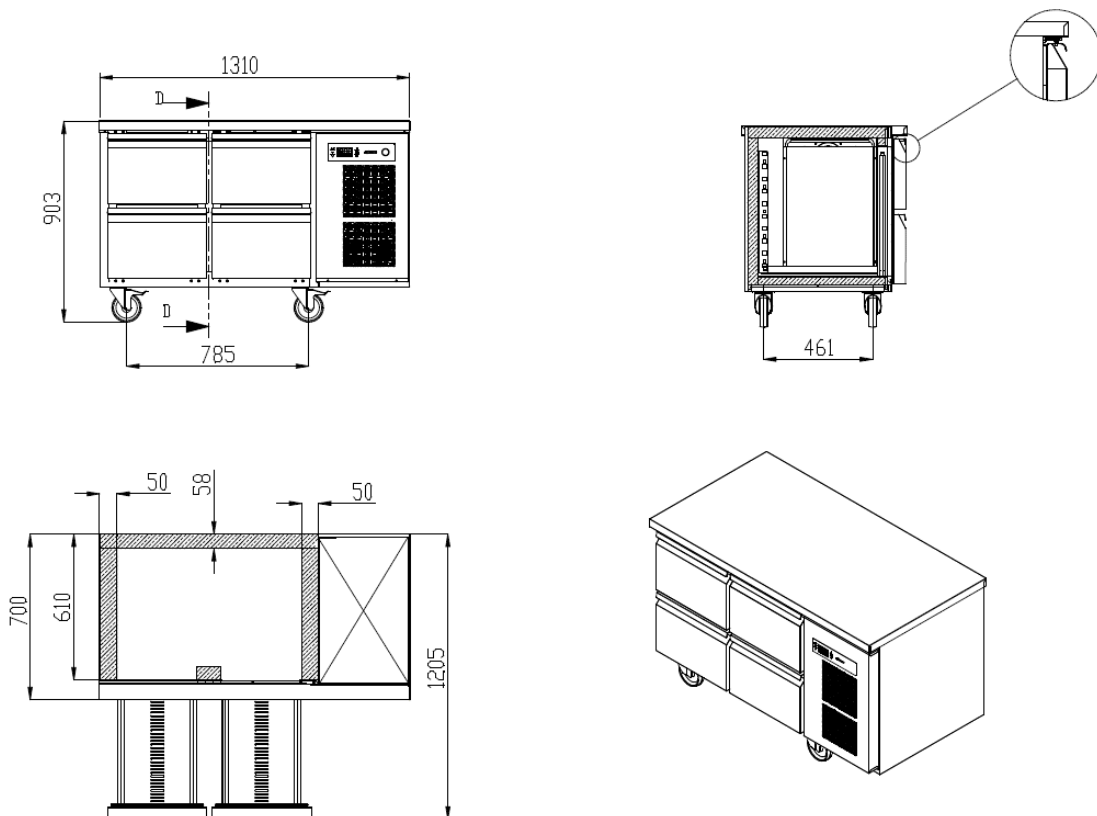

HOSHIZAKI

PREMIER UNDERCOUNTER



PREMIER K-M 2 A 3D 3D L

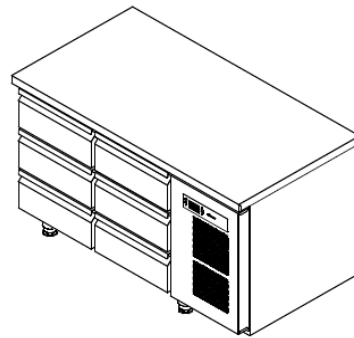
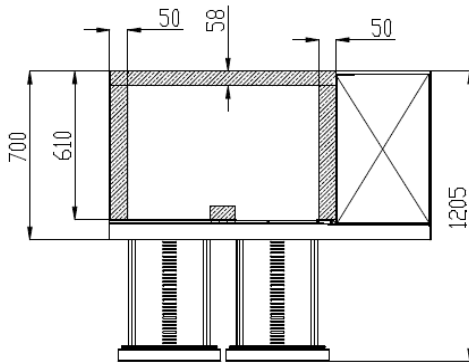
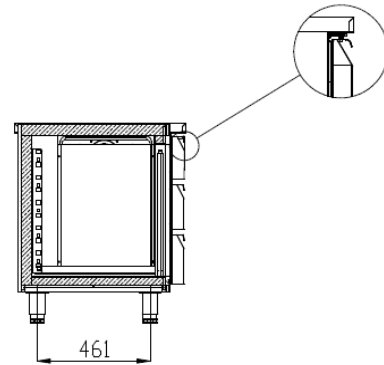
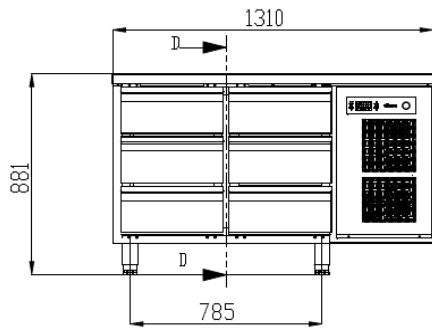

PREMIER K-M 2 A 3D 3D C

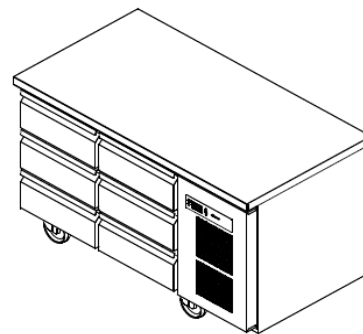
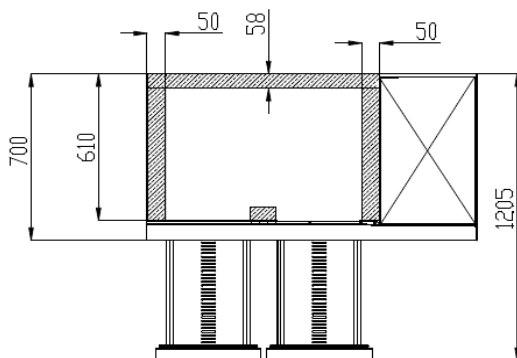
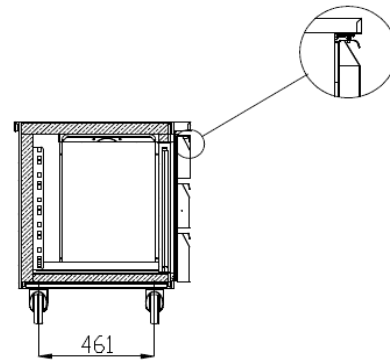
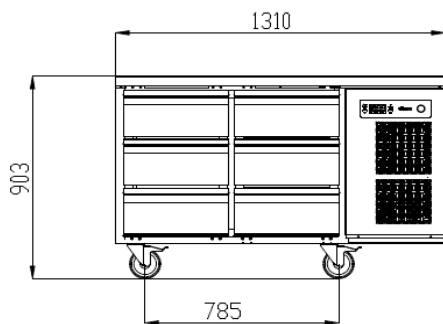

HOSHIZAKI

PREMIER UNDERCOUNTER



PREMIER K-M-F 3 A DL DR DR L

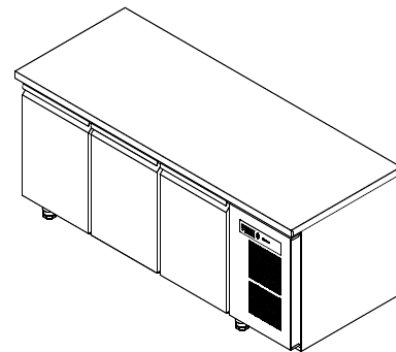
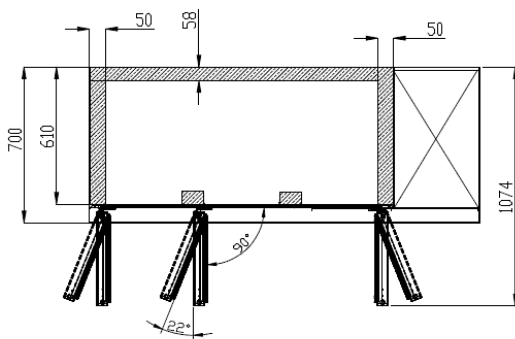
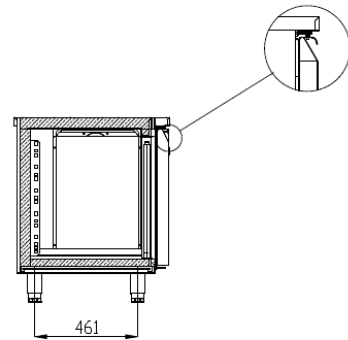
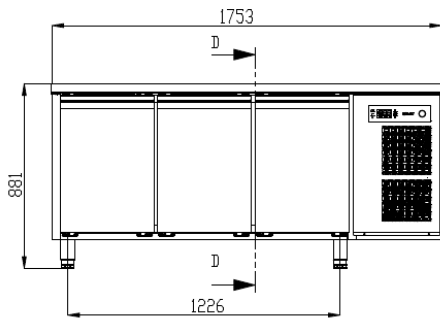

PREMIER K-M-F 3 A DL DR DR C

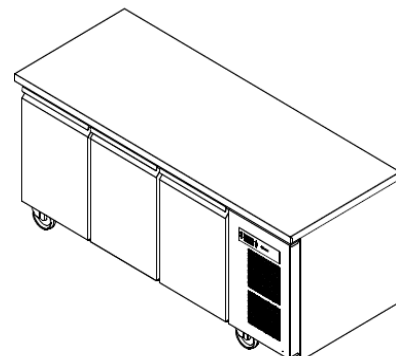
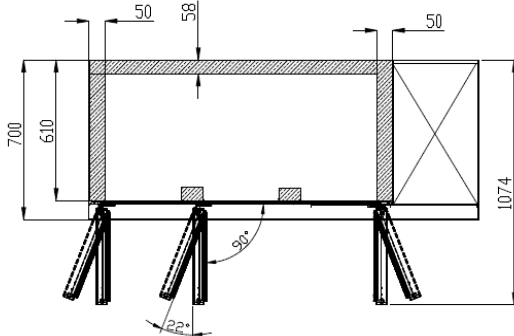
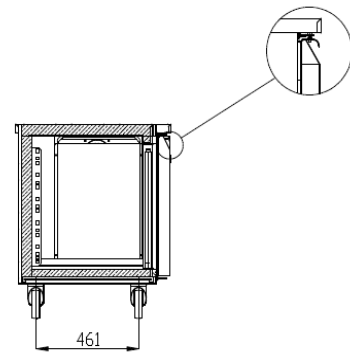
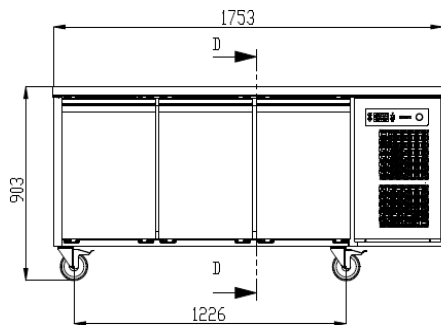

HOSHIZAKI

PREMIER UNDERCOUNTER



PREMIER K-M 3 A 2D 2D 2D L

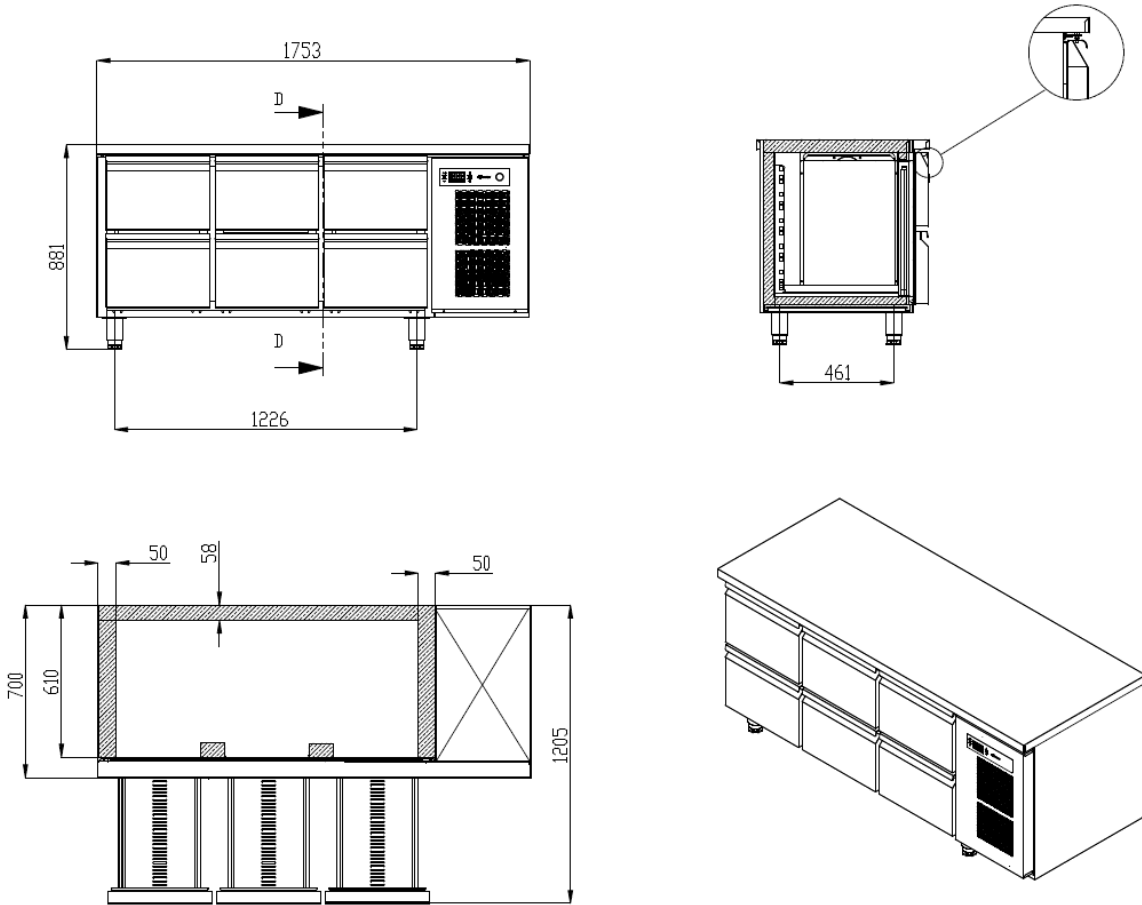

PREMIER K-M 3 A 2D 2D 2D C

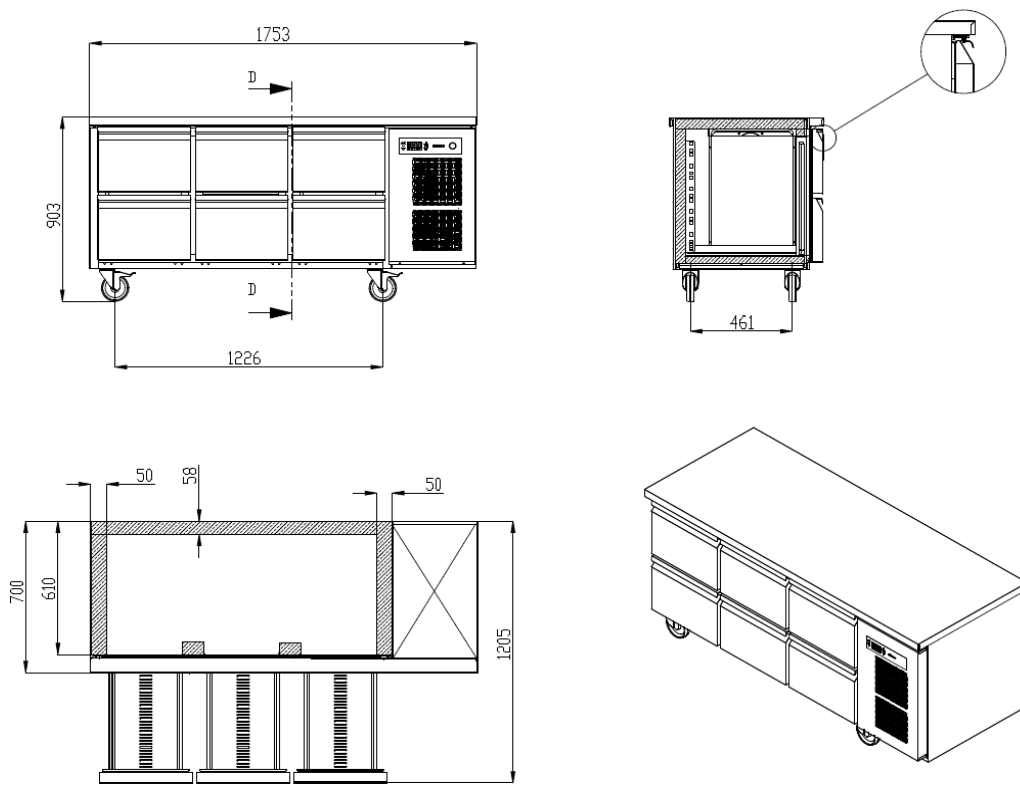

HOSHIZAKI

PREMIER UNDERCOUNTER



PREMIER K-M 3 A 3D 3D 3D 3 L

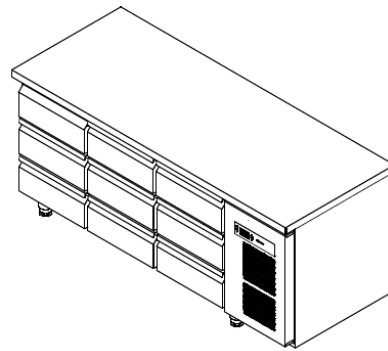
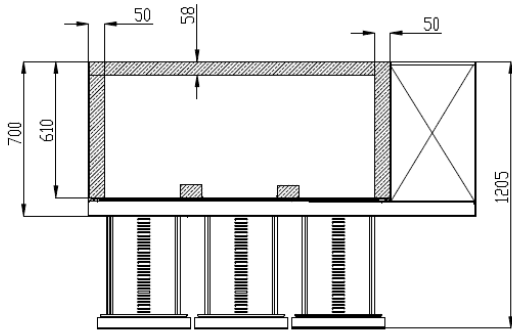
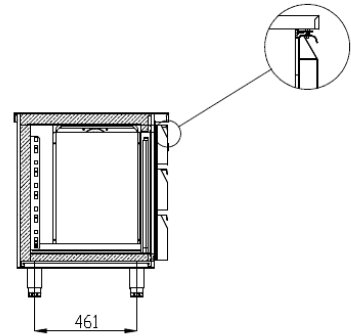
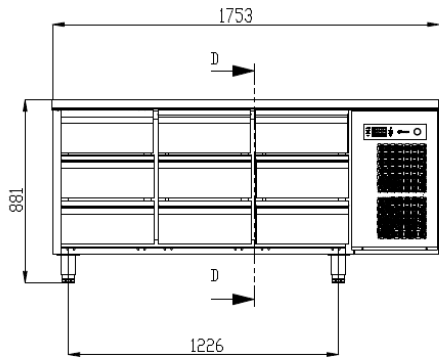

PREMIER K-M 3 A 3D 3D 3D C

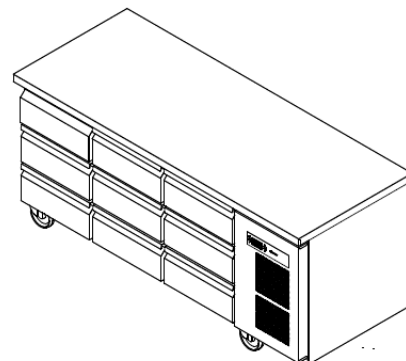
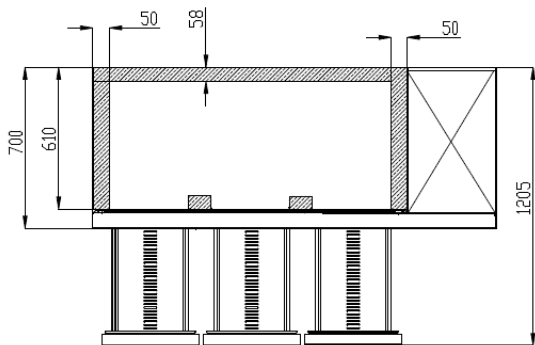
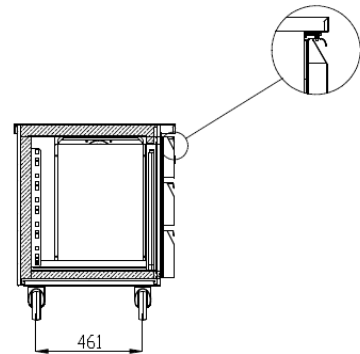
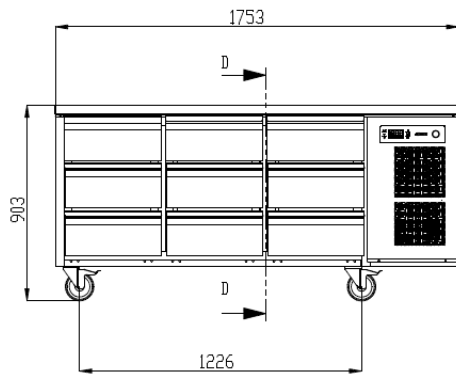

HOSHIZAKI

PREMIER UNDERCOUNTER



PREMIER K-M-F 4 A DL DL DR DR L

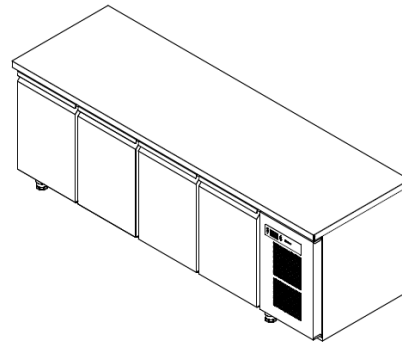
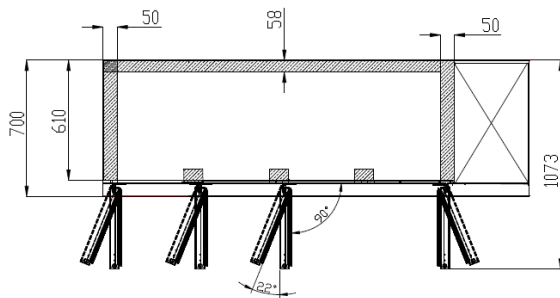
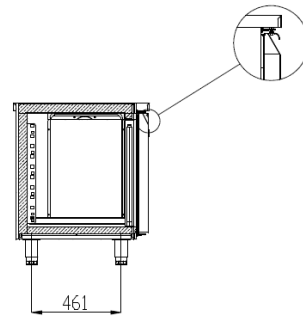
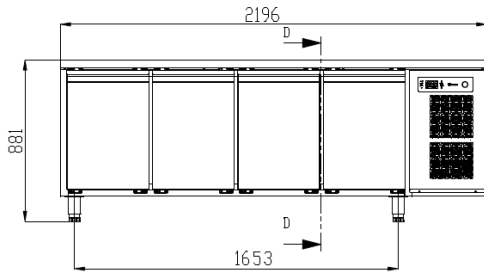

PREMIER K-M-F 4 A DL DL DR DR C

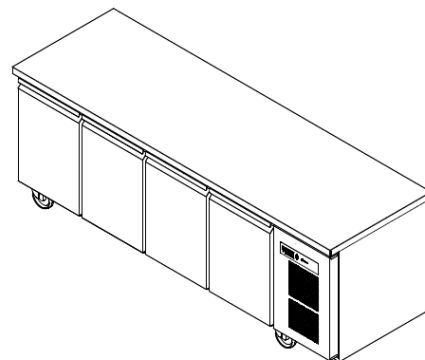
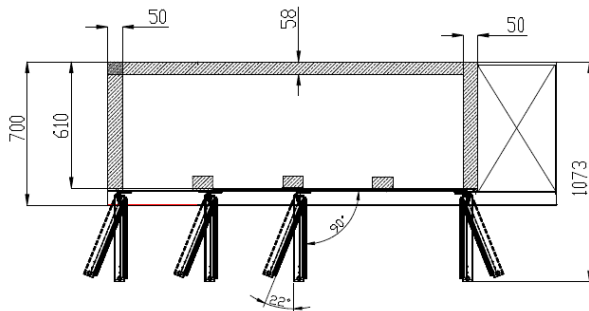
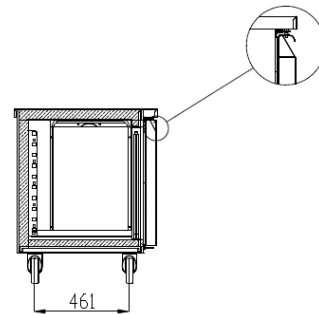
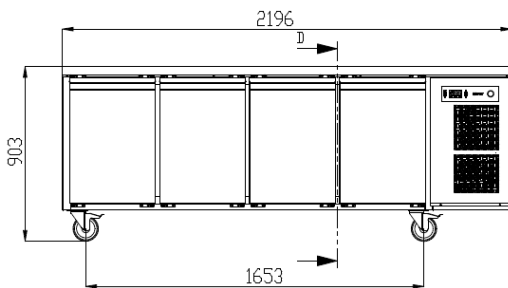

HOSHIZAKI

PREMIER UNDERCOUNTER



PREMIER K-M 4 A 2D 2D 2D 2D L

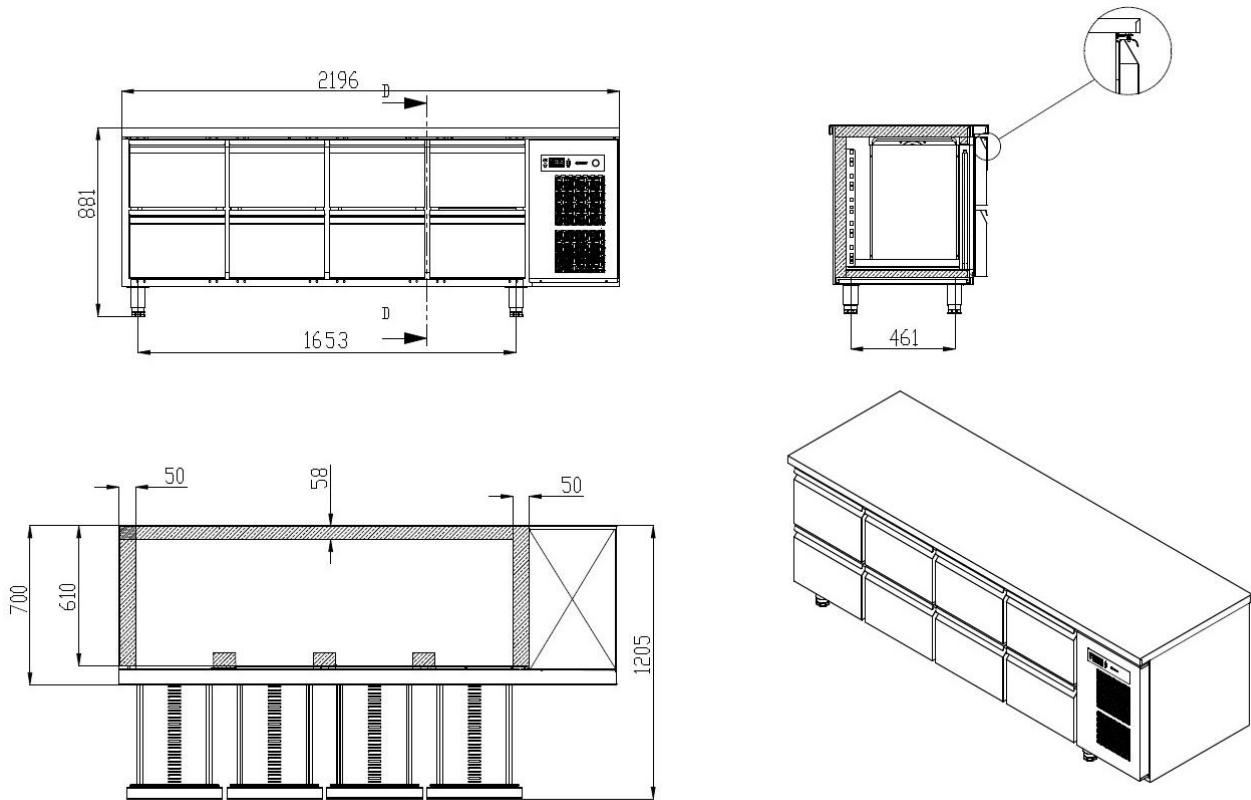

PREMIER K-M 4 A 2D 2D 2D 2D C

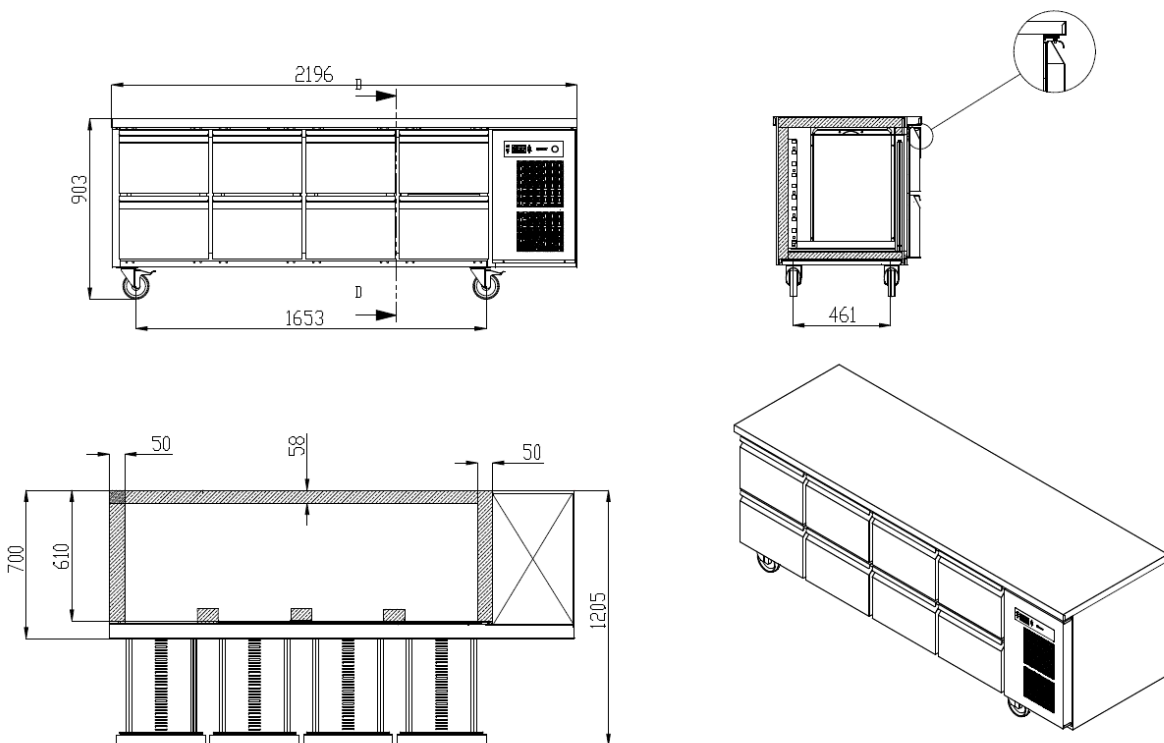

HOSHIZAKI

PREMIER UNDERCOUNTER



PREMIER K-M 4 A 3D 3D 3D 3D L

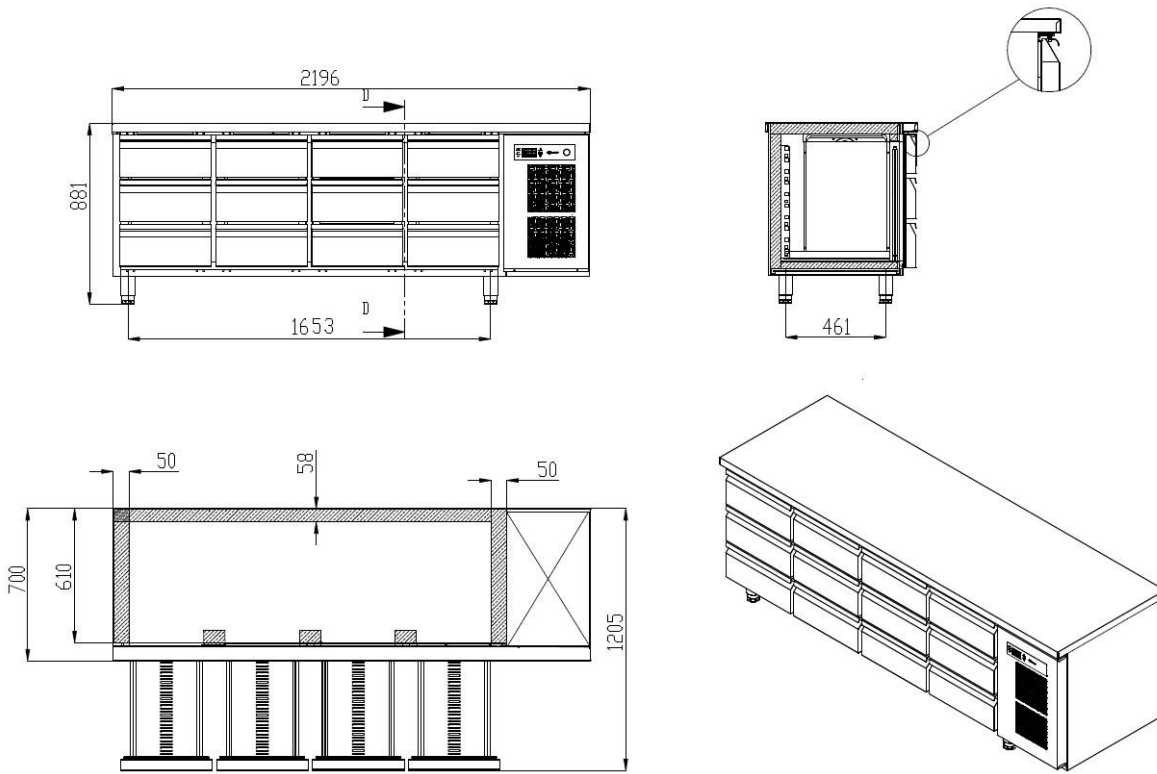

PREMIER K-M 4 A 3D 3D 3D 3D C

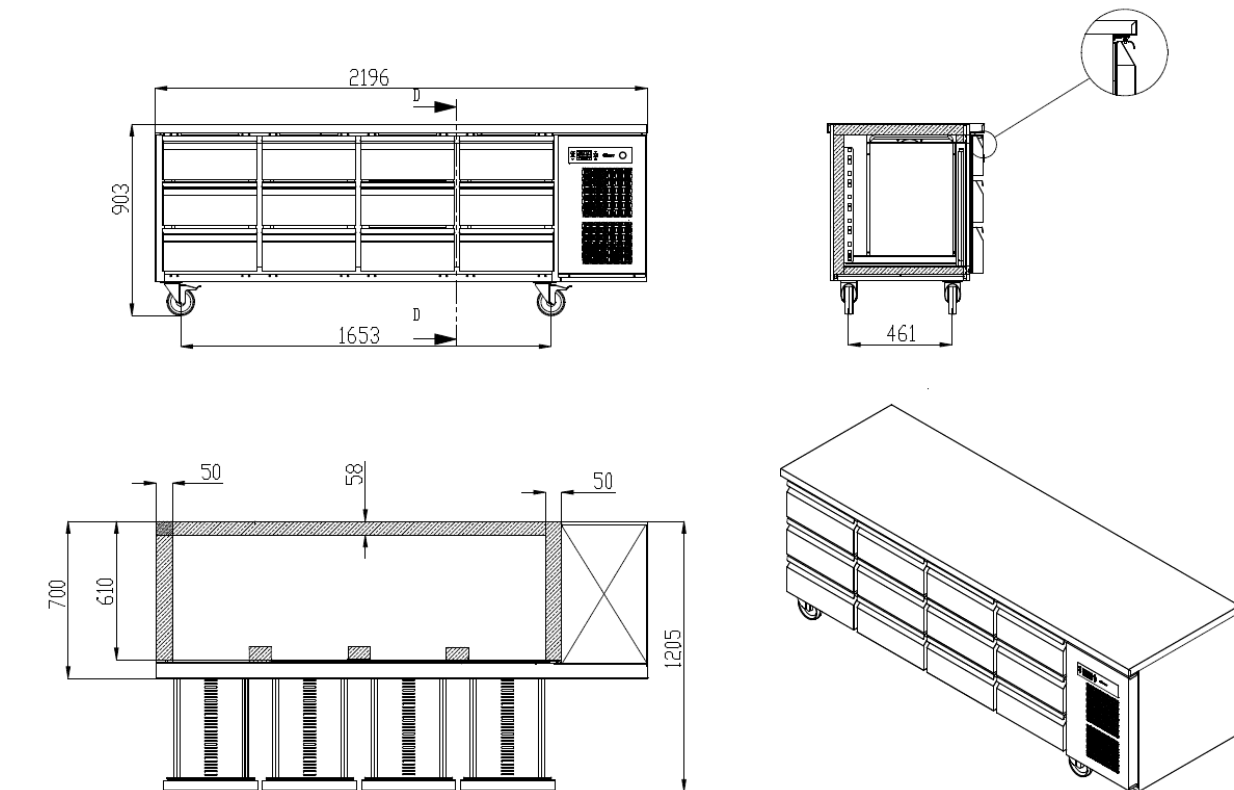

PREMIER UNDERCOUNTER

VI. KJØLESKJEMA - ELEKTRISK KOBLINGSSKJEMA

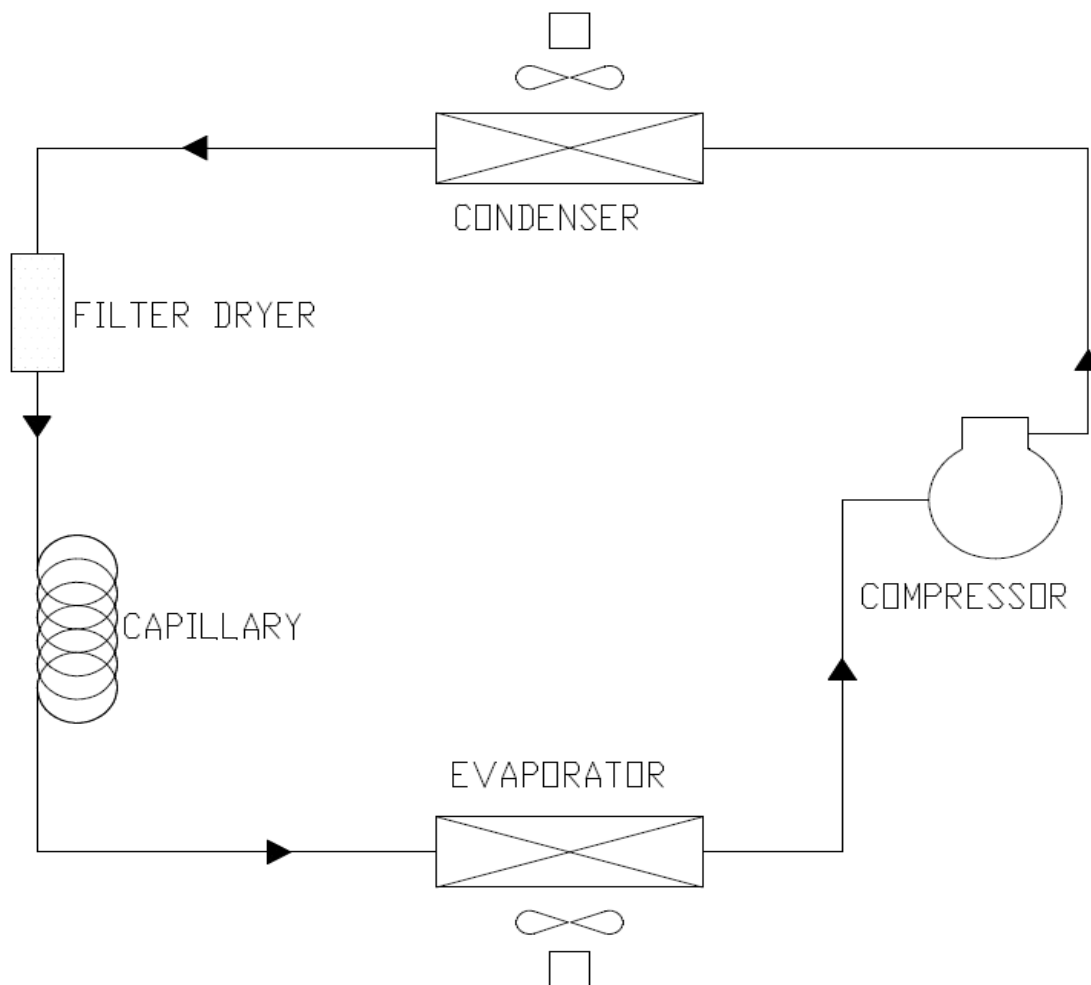



HOSHIZAKI

PREMIER UNDERCOUNTER

ELEKTRISK KOBLINGSSKJEMA

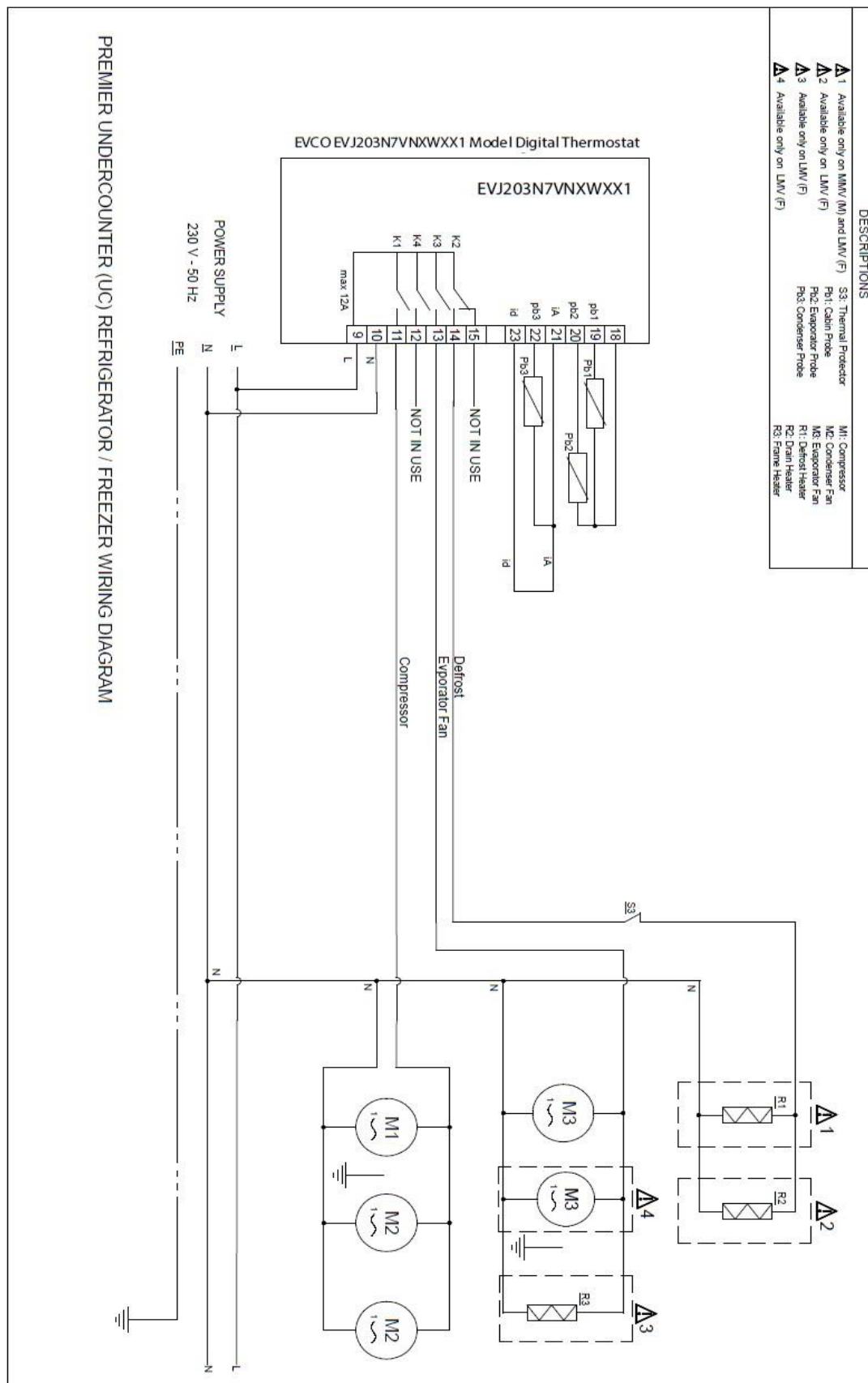

PREMIER UNDERCOUNTER

VII. VEDLIKEHOLDSDIAGNOSE

Tabellen nedenfor viser forskjellige problemer du kan støte på. Hvis en alarmkode vises, har det oppstått en funksjonsfeil. Korriger mulige årsaker før du tilbakestill skapet. Mulige årsaker og løsninger står oppført nedenfor.

Hvis en feilkode vedvarer etter at du har utført kontrollene nedenfor, kontakter du en kvalifisert tekniker. Feilmeldingens innhold må fastsettes. Produktdetaljer, inkludert serienummer, finner du på produktets typeskilt.

PROBLEM	MULIG ÅRSAK	LØSNING	
Skapet fungerer ikke	Skapet får ikke strøm	Sjekk om støpselet og ledningen er uten feil	
Kompressoren stopper sjelden	Omgivelsestemperaturen er for høy	Ventilasjonen må forbedres	
	Kondensatoren eller kondensatorfilteret er blokkert	Kontroller og rengjør kondensatorfilteret regelmessig	
	Dørpakninger tetter ikke ordentlig	Ring autorisert tekniker for å skifte pakningen	
	Rim på fordamperen		Legg ikke varme matvarer i skapet
			Legg ikke matvarer med høyt vanninnhold i skapet med mindre de oppbevares i lukkede beholdere
		Start manuell avrimingssyklus	
	Fordampervifte(r) fungerer ikke	Ring autorisert tekniker for å bytte viften(e)	
Vann som renner over fra kondensvannbrettet	Hyppig plassering av varme matvarer i skapet	Legg ikke varme matvarer i skapet	
		Plasser bare mat med høyt vanninnhold i lukkede beholdere i skapet	
	Hyppig åpning av dør eller skuffer	Kontroller om skapets spesifikasjoner er egnet for nåværende bruk	
For høy temperatur i skap	Kondensatoren er blokkert av smuss og støv	Kontroller og rengjør kondensatorfilteret regelmessig	
	Luftstrømmen i skapet er blokkert	Fjern matvarer som hindrer fri luftstrøm	
	Omgivelsesluft slipper inn i skapet		Sjekk at døren er lukket
			Se om det er skader på dør- og skuffepakninger
			Kontakt autorisert tekniker
	Rim på fordamperen	Start manuell avrimingssyklus	

PREMIER UNDERCOUNTER

VIII. FJERNING OG UTSKIFTING

KASTE SKAPET

- i. Kjølemediet i skapet kan identifiseres fra typeskiltet.
- j. Skapet er produsert av resirkulerbare materialer i samsvar med EUs regelverk. Mot slutten av levetiden må derfor skapet fraktes til egnet resirkuleringsanlegg, og kastes der.
- k. Skapet skal ikke resirkuleres som metall eller husholdningsavfall.
- l. Unngå klemme sammen kjølekretsen.



VIKTIG

Følg lokale lover og forskrifter når du kaster skapet.

HOSHIZAKI

PREMIER UNDERCOUNTER



Med enerett. Hoshizaki forbeholder seg retten til å endre funksjoner og informasjon i denne håndboken

Kontaktinformasjon

Hovedkontorer

Hoshizaki Europe B.V – All other countries in Europe and Africa

TEL: +31 (0)20 6918499

sales@hoshizaki.nl -- <http://hoshizaki-europe.com/>

Avdelinger

Hoshizaki UK - UK, Ireland

TEL: +44 (0)845 456 05 85

uksales@hoshizaki.co.uk

Hoshizaki Deutschland - Germany, Switzerland, Austria

TEL: +49 (0)5121 697370

vertrieb@hoshizaki.de

Hoshizaki Benelux - Netherlands, Belgium, Luxembourg

TEL: +31 (0)85 0188370

info@hoshizaki.nl

Hoshizaki France - France

TEL: +33 (0)1 48 63 93 80

info@hoshizaki.fr

Hoshizaki Iberia - Spain, Portugal

TEL: +34 (0)93 478 09 52

info@hoshizaki.es

Hoshizaki Denmark - Denmark

TEL: +45 89 88 53 50

salg@hoshizaki.dk

Hoshizaki Norway - Norge

TEL: +47 22 88 17 50

salg@hoshizaki.no

Hoshizaki Sweden - Sverige

TEL: +46 108 84 87 47

OrderSE@hoshizaki.dk

Hoshizaki Italia – Italia

TEL: +39 348 3022156

commerciale@hoshizaki.it